



LG936L SALES TRAINING

Jan 15, 2018

SDLG LG936L

Feature & Benefits - Machine Walkaround

Currently LG936L overseas products resources include the following order number.

The details please refer to the latest product resource content.

E3623115A36

E3623115AK6

E3623115A29

E3623115AK9

E3623115GK6

E3623115Q29

E3626115A29

SDLG LG936L

Feature & Benefits - Machine Walkaround

ALL

Content

- Main features of the product
- Custom benefits and value
- Optional component
- Attachment

SDLG LG936L

ALL

The factors which influence customers...



SDLG LG936L

Machine Walkaround – Starting point

ALL



- Where to introduce my products is OK.
- We recommend the starting from the front of SDLG LG936L.
- Remember what is customer value most when buying machine.
 - ✓ Special configuration
 - ✓ Customer perception
- This part will be based on the characteristics and advantages of loader, let the customer know its value and benefit.

AVAILABILITY



PERFORMANCE



PRODUCTIVITY



OPERATOR ENVIRONMENT



OPERATING COST



SAFETY



SDLG LG936L

Standard bucket

ALL



Feature:

- Standard bucket capacity 1.8 cubic meters.
(E3623115Q29 with standard 2.5m³ LM bucket)
- Rear strengthen the high barrier.
- The butcher plate and wearing plate adopt wear-resisting material.
- The bucket bottom and side panel adopts flitch to strengthen.

Benefit:

- To prevent the material after the throw damaging the work device.
- More wear-resisting, improve more than 60% in the service life.

AVAILABILITY



PERFORMANCE



PRODUCTIVITY



OPERATOR ENVIRONMENT



OPERATING COST



SAFETY



SDLG LG936L

Z-bar linkage

ALL



Feature:

- Optimization design Z-bar linkage.
- Using enhanced movable arm and beam, continuous intelligent welding technology, blasting treatment after welding.

Benefit:

- Large transmission ratio, improve ground lifting force and shovel digging force.
- More reliable and more efficient, longer working life.

AVAILABILITY



PERFORMANCE



PRODUCTIVITY



OPERATOR ENVIRONMENT

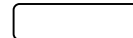

OPERATING COST



SAFETY

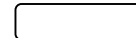

SDLG LG936L

Front lights and working lights

ALL



Feature:

- Equipped with 2 set of high-power Hella headlamp, wide range, high installation, increase protection and conform to the E-Mark certification.
- Bridge before and after the top is equipped with four Hella work lamp.
- LED lamps as an option.

Benefit:

- Significantly enhance performance, improve dark environment operation safety and effectively prevent litter damage.
- Optimize collocation installation, ensure good lighting

AVAILABILITY

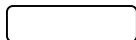

PERFORMANCE



PRODUCTIVITY



OPERATOR ENVIRONMENT



OPERATING COST

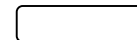

SAFETY



SDLG LG936L

Center Hinge & Frames

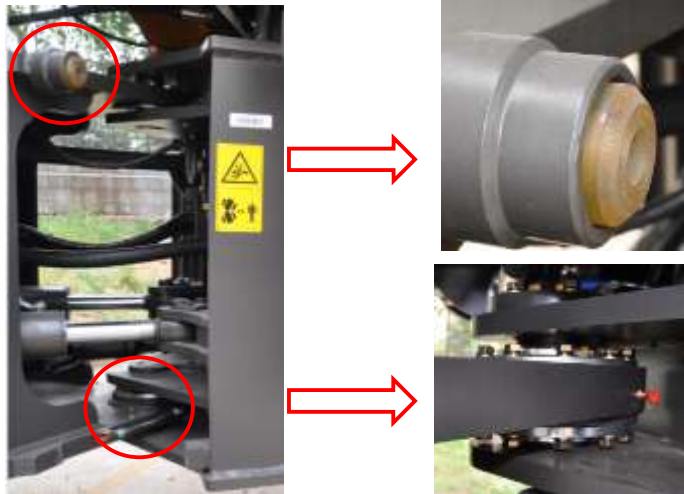

Feature:

- Articulated center close to the layout, articulated distance widened design.
- **The steering limiting flexible cushion design.**
- Tapered roller bearings, strengthening seal design.

Benefit:

- Excellent stability, smaller turning radius
- Improve operation comfort, reduce fatigue.
- A longer service life.

AVAILABILITY



PERFORMANCE



PRODUCTIVITY



OPERATOR ENVIRONMENT

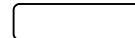

OPERATING COST



SAFETY



SDLG LG936L

Access ladder, handrails & anti-slip

ALL



Feature:

- Conform to the ergonomic design of armrest and arc ladder design.
- Add a rope ladder and ladder design.

Benefit:

- To improve the operator safety
- Reduce operator fatigue strength, Reduce the incidence of accidents



AVAILABILITY

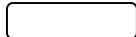

PERFORMANCE

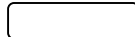

PRODUCTIVITY

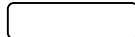

OPERATOR ENVIRONMENT



OPERATING COST

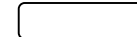

SAFETY



SDLG LG936L

Access ladder, handrails & anti-slip

ALL



Feature:

- Prevent slippery ladder
- Humanized armrest
- The antiskid design of working face

Benefit:

- Ensure safety
- Easily up and down the machine

AVAILABILITY



PERFORMANCE



PRODUCTIVITY



OPERATOR ENVIRONMENT

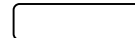

OPERATING COST



SAFETY



SDLG LG936L

Care Cab

ALL



Feature:

- According to the ergonomic design of new type of Cab.
- Cab is installed on the shock absorber.

Benefit:

- Sealed performance is good.
- Safe and comfortable.
- The driver can continuous operation for a long time without feeling tired.

AVAILABILITY

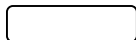

PERFORMANCE

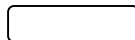

PRODUCTIVITY

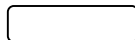

OPERATOR ENVIRONMENT

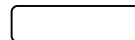

OPERATING COST



SAFETY



SDLG LG936L

Air-conditioning system

ALL

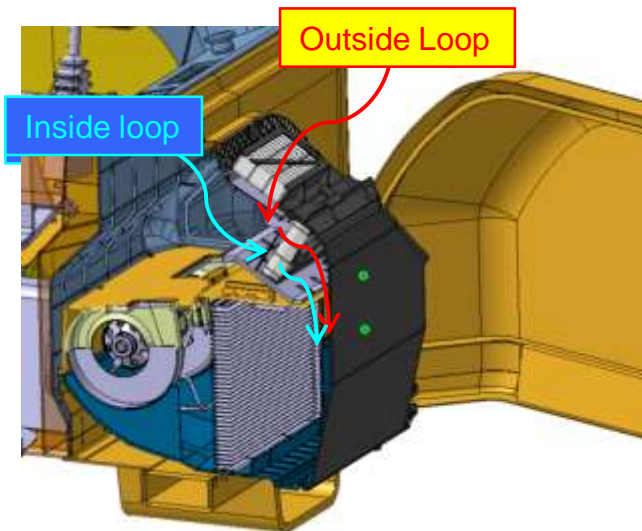

Feature:

- Improve the leakproofness of the cab.
- Large capacity air conditioning system.
- Inside and outside circulation with the air filter which on the outside.

Benefit:

- Noise reduction, sound insulation, heat insulation.
- 52 degrees ambient temperature in cabin down to 30 degrees in 5 minutes, 20 minutes to below 22 degrees.
- Purify air, easy to clean and replace filter.

AVAILABILITY

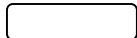

PERFORMANCE

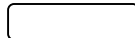

PRODUCTIVITY



OPERATOR ENVIRONMENT



OPERATING COST

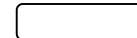

SAFETY



SDLG LG936L

Care Cab



Feature:

- Standard seat comfort meet five standards
- Six bearing with damping shock adjustment
- Configure your seat belt

Benefit:

- Greatly improve the operator comfort.
- Conform to the ergonomic design, reduces the fatigue strength.
- To ensure the safety of drivers.

AVAILABILITY

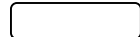

PERFORMAN

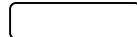

PRODUCTIVIT



OPERATOR ENVIRONMENT



OPERATING COST

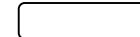

SAFETY



SDLG LG936L

Care Cab – Driving conditions

ALL



Feature:

- Specialization of luxury interior.
- Cup holder, multifunctional configuration
- Air-conditioning outlet increase glass blowing straight channels.

Benefit:

- Car interiors, and beautiful
- More humanized design
- Defrost glass



AVAILABILITY



PERFORMANCE



PRODUCTIVITY



OPERATOR ENVIRONMENT

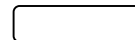

OPERATING COST

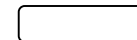

SAFETY

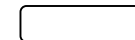

SDLG LG936L

Care Cab - Visibility

ALL



Feature:

- The cockpit vision conform to the industrial safety design.

Benefit:

- Vision is good.
- Fewer blind area.



AVAILABILITY

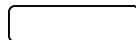

PERFORMANCE

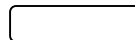

PRODUCTIVITY

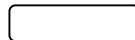

OPERATOR ENVIRONMENT



OPERATING COST

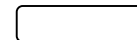

SAFETY



SDLG LG936L

Parking Brake

Suit for the old product
ahead of 2017:

E3613115A36

E3613115A39

E3613115AK6

E3613115AK9

E3616115A39

E3616115AK6



Feature:

- The electro-hydraulic control parking brake

Benefit:

- Brake is reliable, operation is simple and convenient
- Can be used for emergency situation and improve the safety

AVAILABILITY



PERFORMANCE



PRODUCTIVITY



OPERATOR ENVIRONMENT

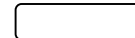

OPERATING COST



SAFETY



SDLG LG936L

Parking Brake



Feature:

- The electro-hydraulic control drum parking brake

Benefit:

- Brake is reliable, operation is simple and convenient
- Can be used for emergency situation and improve the safety

Suit for the product since 2017:

E3623115A36

E3623115AK6

E3623115A29

E3623115AK9

E3623115GK6

E3623115Q29

E3626115A29

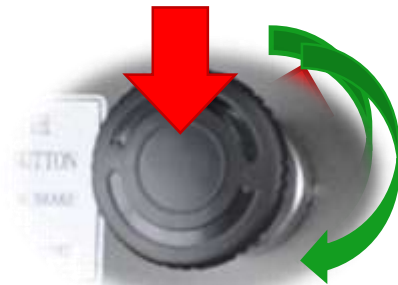

AVAILABILITY



PERFORMANCE



PRODUCTIVITY

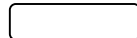

OPERATOR ENVIRONMENT



OPERATING COST

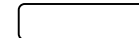

SAFETY



SDLG LG936L

Contronic monitoring system

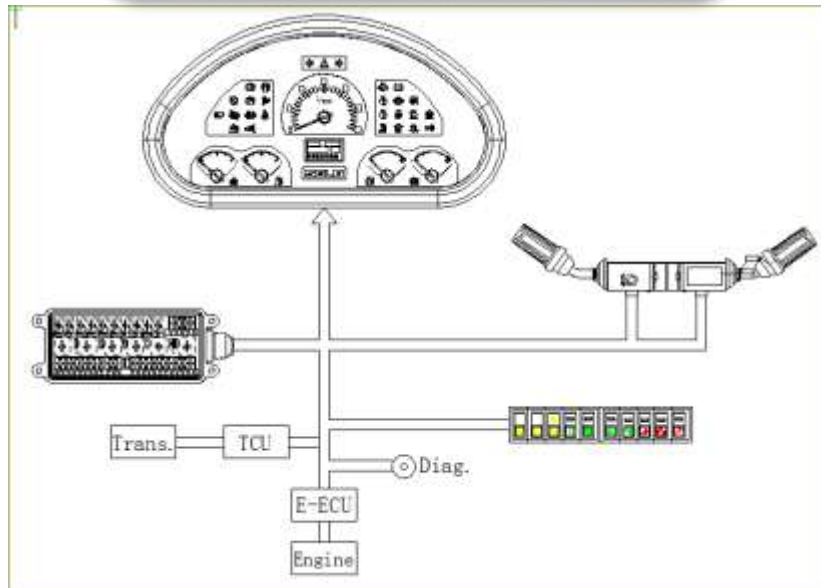

Feature:

- Step meter monitoring system (the latest bridge standard equipped).

Benefit:

- Reasonable layout of light, easy to distinguish.
- Provide the operator with the machine running information and early warning.
- Monochrome screen can realize the the most part of vehicle information (including speed) of real-time display.

AVAILABILITY



PERFORMANCE



PRODUCTIVITY



OPERATOR ENVIRONMENT

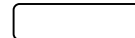

OPERATING COST



SAFETY

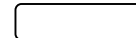

SDLG LG936L

Working hydraulic system

Lift system

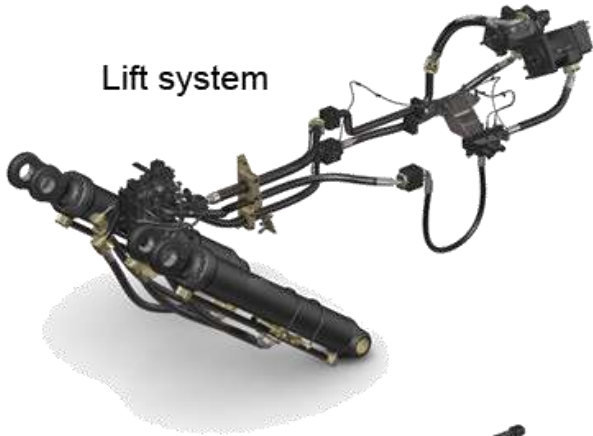

Tilt system



Feature:

- Make optimization design efficient system.
- Single handle pilot control.

Benefit:

- High impermeability of the hydraulic system.
- Single handle pilot operation, operating force is small, reducing operator fatigue strength.
- Reasonable power matching more energy efficient.

AVAILABILITY



PERFORMANCE



PRODUCTIVITY



OPERATOR ENVIRONMENT



OPERATING COST



SAFETY



SDLG LG936L

Working hydraulic system

E3623115A29
E3623115Q9
E3626115A29



Feature:

- Two units of main control valve.
- Single handle pilot control.

Benefit:

- High reliability, good sealing and suitable matching.
- Convenient and easy to operate.
- Meet different working conditions.

AVAILABILITY



PERFORMANCE

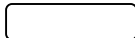

PRODUCTIVITY



OPERATOR ENVIRONMENT



OPERATING COST

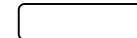

SAFETY



SDLG LG936L

Working hydraulic system

E3623115A36
E3623115AK6
E3623115AK9
E3623115GK6



Feature:

- Three units of main control valve.
- Single handle pilot control.

Benefit:

- Suitable for multiple function equipment, high reliability, good sealing and suitable matching.
- Convenient and easy to operate.
- Meet different working conditions.

AVAILABILITY



PERFORMANCE



PRODUCTIVITY



OPERATOR ENVIRONMENT



OPERATING COST



SAFETY



SDLG LG936L

Steering hydraulic system

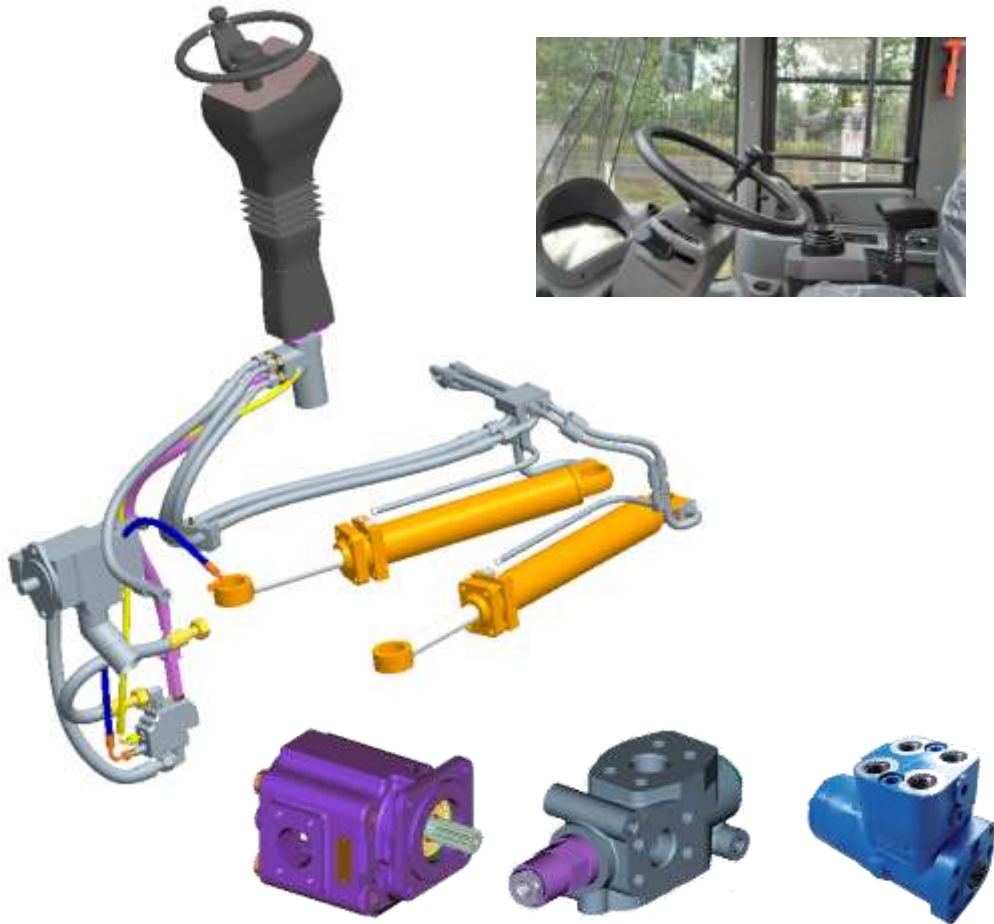

Feature:

- Load sensing hydraulic steering system.
- Coaxial flow amplifying.

Benefit:

- operation is flexible and portable.
- High reliability.

AVAILABILITY

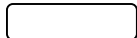

PERFORMANCE

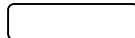

PRODUCTIVITY



OPERATOR ENVIRONMENT



OPERATING COST



SAFETY



SDLG LG936L

Cab

E3623115A29
E3623115Q9
E3626115A29
E3623115A9

Feature:

- Standard cab.

Benefit:

- Large interior space, good sealing, car's interiors, improve the driving comfort.
- Good vision for outside of cab to reduce the blind spot.



AVAILABILITY

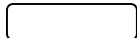

PERFORMANCE



PRODUCTIVITY



OPERATOR ENVIRONMENT



OPERATING COST

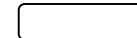

SAFETY



SDLG LG936L

Cab

E3623115A36
E3623115AK6
E3623115G6



Feature:

- Standard FORPS&ROPS cab.

Benefit:

- ISO standard, large interior space, good sealing, car's interiors, improve the driving comfort.
- Good vision for outside of cab to reduce the blind spot.

AVAILABILITY



PERFORMANCE

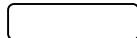

PRODUCTIVITY



OPERATOR ENVIRONMENT



OPERATING COST

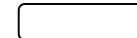

SAFETY



SDLG LG936L

Adjustable steering wheel



Feature:

- Adjustable steering wheel(top rake is 15 ° , caster is 13 °)

Benefit:

- Easy to operate.
- According the operators's different need to adjust the Angle.
- High comfort.

AVAILABILITY

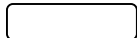

PERFORMANCE

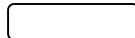

PRODUCTIVITY



OPERATOR ENVIRONMENT



OPERATING COST



SAFETY



SDLG LG936L

Service access – Hood & Centralized filters



Feature:

- Large engine hood, the side door opening large.
- Engine hood paste sound-absorbing material.



Benefit:

- Facilitate maintenance
- Reduce the noise

AVAILABILITY



PERFORMANCE

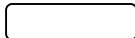

PRODUCTIVITY



OPERATOR ENVIRONMENT

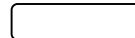

OPERATING COST



SAFETY



SDLG LG936L

Service access –Centralized filters



Feature:

- Fuel filter and oil filter centralized layout.

Benefit:

- Maintenance is convenient.



AVAILABILITY



PERFORMANCE



PRODUCTIVITY

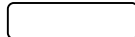

OPERATOR ENVIRONMENT

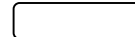

OPERATING COST

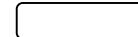

SAFETY

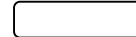

SDLG LG936L

Battery

ALL



Feature:

- Two groups of battery installed in the battery box, Close to the starter.
- Equips with manual power switch in the box.

Benefit:

- Ensure long battery life and high reliability.
- Easy access.
- Convenient manually disconnect and connect the main circuit grounding.

AVAILABILITY



PERFORMANCE



PRODUCTIVITY



OPERATOR ENVIRONMENT



OPERATING COST



SAFETY



SDLG LG936L

Ground level fueling

ALL



Feature:

- The ground standard height of the fuel oil supply.
- special fuel tank cover with lock and protective cover.
- Set up two observation cursor up and down.

Benefit:

- Fuel supply more smooth and convenient to refueling.
- Safe and reliable.
- Convenient to observe the oil level when refueling.

AVAILABILITY



PERFORMANCE



PRODUCTIVITY

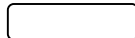

OPERATOR ENVIRONMENT



OPERATING COST



SAFETY



SDLG LG936L

Cooling System

ALL



Feature:

- To increase the cooling system, the grid window frames can rotate 95 degrees, with a limit mechanism.
- All aluminum radiator which double layout, The transmission oil radiator can be rotated 35°.

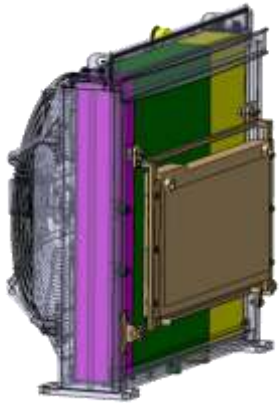

Benefit:

- To improve the radiating efficiency, energy saving, noise reduction.
- Easy to clean.

AVAILABILITY



PERFORMANCE



PRODUCTIVITY



OPERATOR ENVIRONMENT



OPERATING COST



SAFETY



SDLG LG936L

ALL

Lift & Tie down eyes and the locking lever



Feature:

- Set up multiple hole for hoist before and after.
- Front and rear frame lock lever.

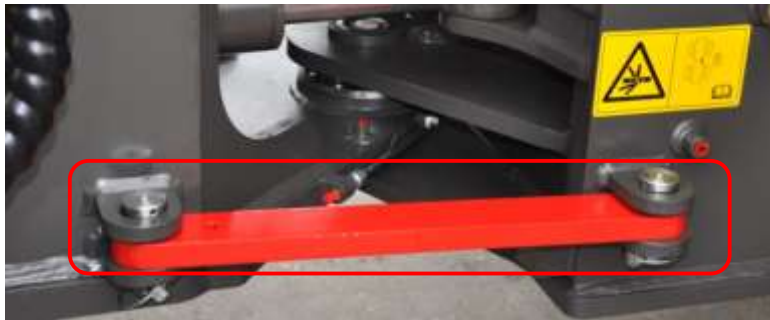

Benefit:

- In transportation and hoisting machine, effectively protect the equipment and personnel safety.

AVAILABILITY

PERFORMANCE

PRODUCTIVITY

OPERATOR ENVIRONMENT

OPERATING COST

SAFETY

SDLG LG936L

Powertrain - Engine

E3623115A29
E3623115Q9
E3623115AK9
E3623115A86
E3623115AK6
E3623115G6

Feature:

- Weichai-Deutz:WP6G125E22 T2 engine.
- Turbocharger.

Benefit:

- Good to meet the demand of customers for the engine.
- High torque, strong power, low fuel consumption, High quality and low emissions, Large power of reserves



AVAILABILITY



PERFORMANCE



PRODUCTIVITY



OPERATOR ENVIRONMENT



OPERATING COST



SAFETY

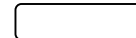

SDLG LG936L

Powertrain - Engine



Feature:

- Dachai-Deutz:BF6M2012 T3 engine.
- Turbocharge and inter-cooling.

Benefit:

- Good to meet the demand of customers for the engine.
- T3 emission, high torque, strong power, low fuel consumption, High quality and low emissions, Large power of reserves

AVAILABILITY



PERFORMANCE



PRODUCTIVITY



OPERATOR ENVIRONMENT

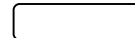

OPERATING COST

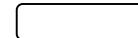

SAFETY



SDLG LG936L

Powertrain - Transmission



Feature:

- SDLG planetary gearbox.
- 2 forward shift and 1 reverse shift.

Benefit:

- Easy to operate, focus on the shift lever only.
- High efficiency and more economic.
- Mature products and high reliability.

AVAILABILITY



PERFORMANCE



PRODUCTIVITY



OPERATOR ENVIRONMENT



OPERATING COST



SAFETY



SDLG LG936L

Powertrain – Enhanced drive axle

ALL

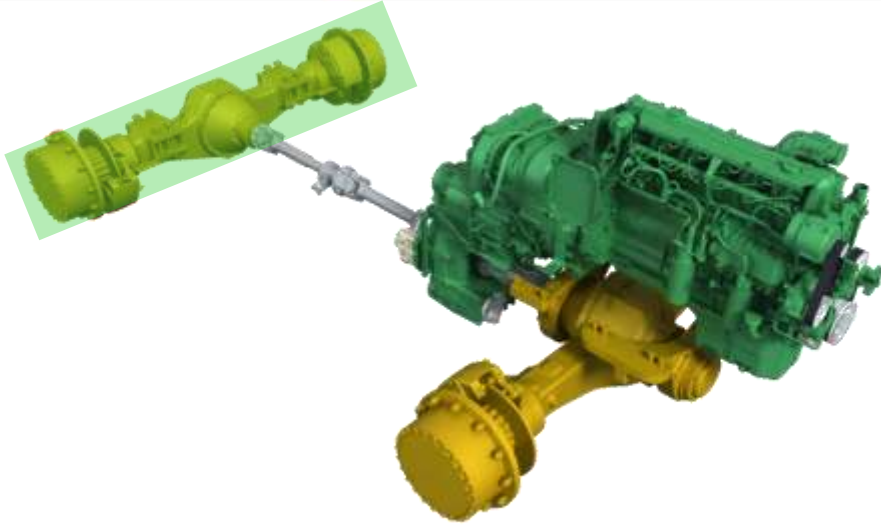

Feature:

- SDLG special reinforced drive axle
- Main transmission and wheel deceleration transmission ratio optimization.
- Using enhanced bevel gear and axle shaft gear.

Benefit:

- The higher intensity
- Increased reliability by more than 60%

AVAILABILITY

PERFORMANCE

PRODUCTIVITY

OPERATOR ENVIRONMENT

OPERATING COST

SAFETY

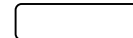

SDLG LG936L

The brake system

ALL



Feature:

- Air cap oil four-wheel forceps disc brake.
- Front axle brake caliper with protection device.
- Dry brake , Double brake pedal.

Benefit:

- High reliability, and maintenance more convenient.
- Safe and more convenient replacement brake lining

AVAILABILITY



PERFORMANCE



PRODUCTIVITY



OPERATOR ENVIRONMENT

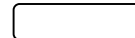

OPERATING COST

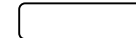

SAFETY



SDLG LG936L

Options – Tyre

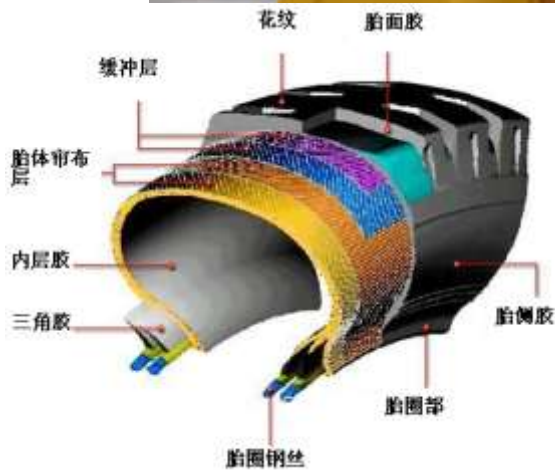

Feature:

- Front axle tire with 12 level.
- 16 or 20 level tires are option.

Benefit:

- Greater carrying capacity.
- Good sidewall protection.

AVAILABILITY



PERFORMANCE

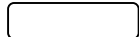

PRODUCTIVITY

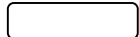

OPERATOR ENVIRONMENT

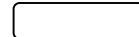

OPERATING COST

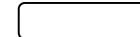

SAFETY



SDLG LG936L

Automatic reset system

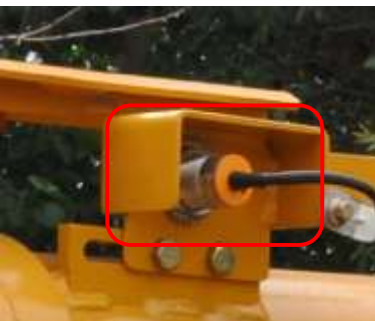

Feature:

- Bucket flat automatically
- Lifting arm rising limit

Benefit:

- Ensure the bucket placed with parallel to the ground floor, reduce the shift of the operating handle, improve working efficiency.
- Ensure the security of the system.

AVAILABILITY



PERFORMANCE

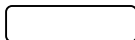

PRODUCTIVITY



OPERATOR ENVIRONMENT

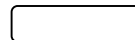

OPERATING COST

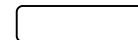

SAFETY



SDLG LG936L

Cables & Connectors



Feature:

- Hydraulic line connected with taper seal O-rings, critical pressure line increase PVC protection

Benefit:

- Pipeline is sealed good , no leakage, improve the reliability.

AVAILABILITY



PERFORMANCE



PRODUCTIVITY



OPERATOR ENVIRONMENT



OPERATING COST



SAFETY



SDLG LG936L

ALL

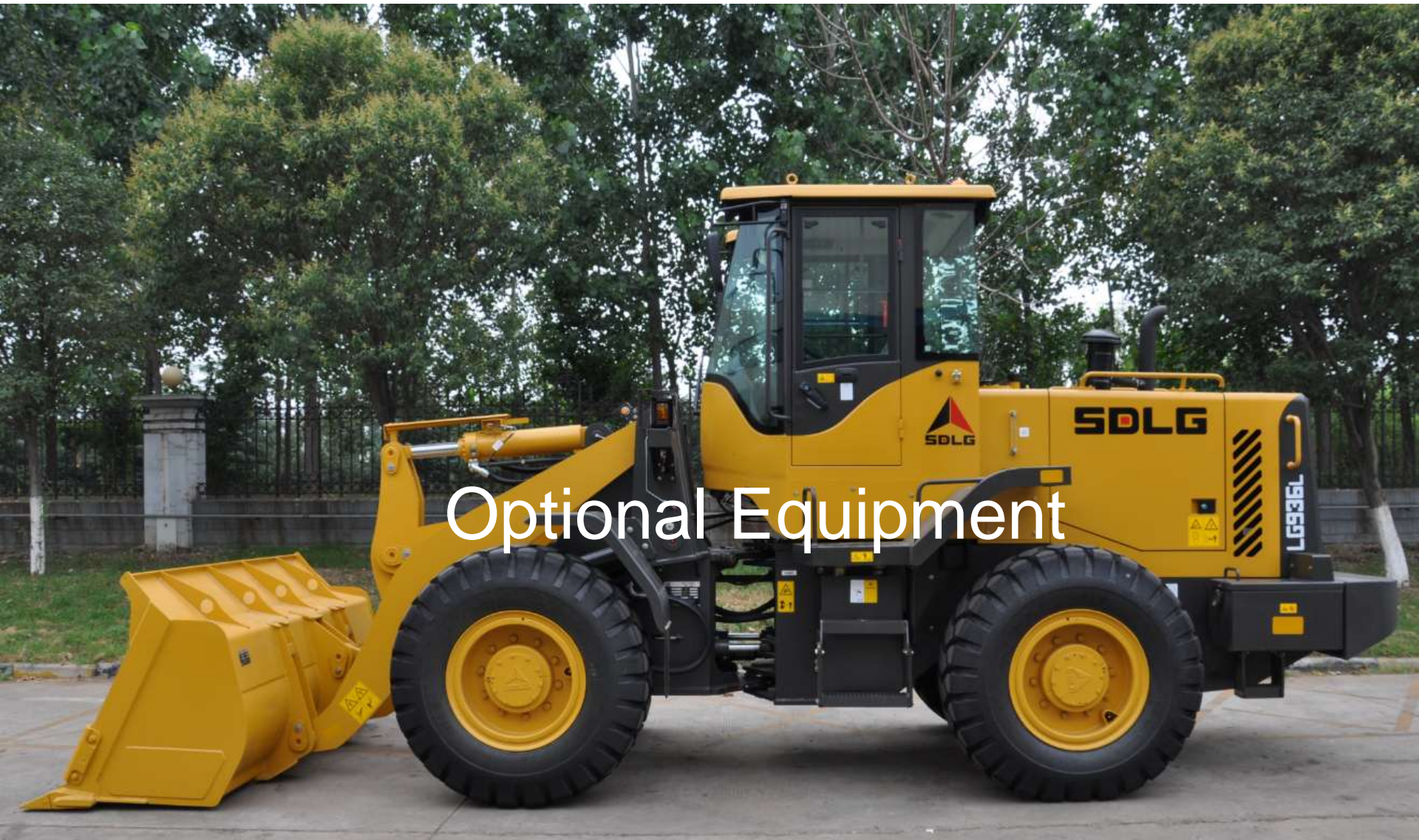

SDLG LG936L

Options Tyre



Feature:

- Tubeless tyre
 - Meridian tyre、 17.5R25-1STTL-LL3
 - Bias tire 、 16 level
 - Bias tire、 Antiskid tyre、 17.5-25-12PR-TL516
 - Herringbone pattern tyre
- Tubed tyre
 - 17.5-25-16PRTT E-2/L-2
 - 17.5-25-20PR-L3

Benefit:

- To choose the most suitable for the tyres according to different working condition , improve the efficiency and security.

AVAILABILITY



PERFORMANCE



PRODUCTIVITY



OPERATOR ENVIRONMENT

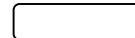

OPERATING COST



SAFETY



SDLG LG936L

Options – 3rd Hydraulic function

ALL



Feature:

- Equipped with two-section or three-section valve.

Benefit:

- Convenient to retrofitting multi-function attachment.

AVAILABILITY

PERFORMANCE

PRODUCTIVITY

OPERATOR ENVIRONMENT

OPERATING COST

SAFETY

SDLG LG936L

Single Handle pilot valve



Feature:

- Double Handle Pilot System.

Benefit:

- To meet different operating habits.

AVAILABILITY



PERFORMANCE



PRODUCTIVITY



OPERATOR ENVIRONMENT



OPERATING COST



SAFETY



SDLG LG936L

Oil bath air filter

E3623115A29
 E3623115Q9
 E3623115AK9
 E3623115A86
 E3623115AK6
 E3623115G6



Feature:

- Oil bath air filter as an option.

Benefit:

- Adapt to the bad conditions of the dust and environment, effective protection, improve the engine life.

AVAILABILITY



PERFORMANCE



PRODUCTIVITY



OPERATOR ENVIRONMENT

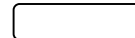

OPERATING COST

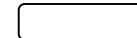

SAFETY

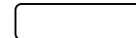

SDLG LG936L



Attachments



SDLG LG936L

GP bucket

E3623115A36
E3623115A29
E3623115GK6
E3626115A29
3623115A29

Feature:

- Standard bucket, bucket capacity 1.8 m³.
- The standard bucket teeth is connected by bolt.
- Bucket bottom thickening.

Benefit:

- Firm.
- Wear-resisting.

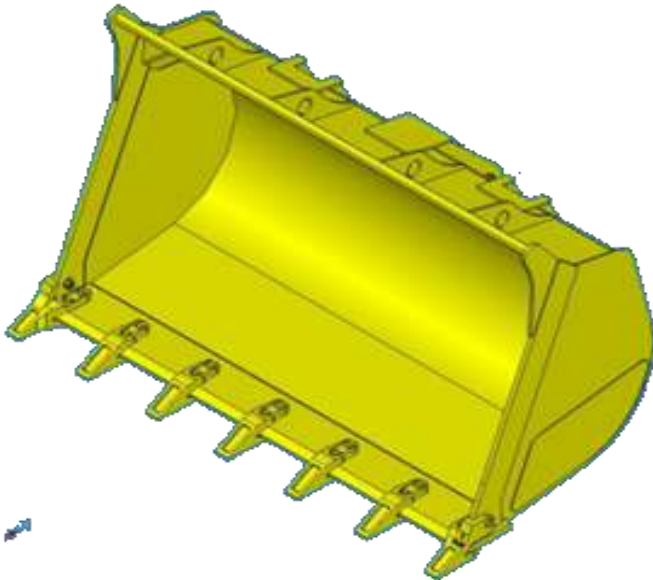

AVAILABILITY

PERFORMANCE

PRODUCTIVITY

OPERATOR ENVIRONMENT

OPERATING COST

SAFETY

SDLG LG936L

GP bucket

E3623115A36
E3623115A29
E3626115A29

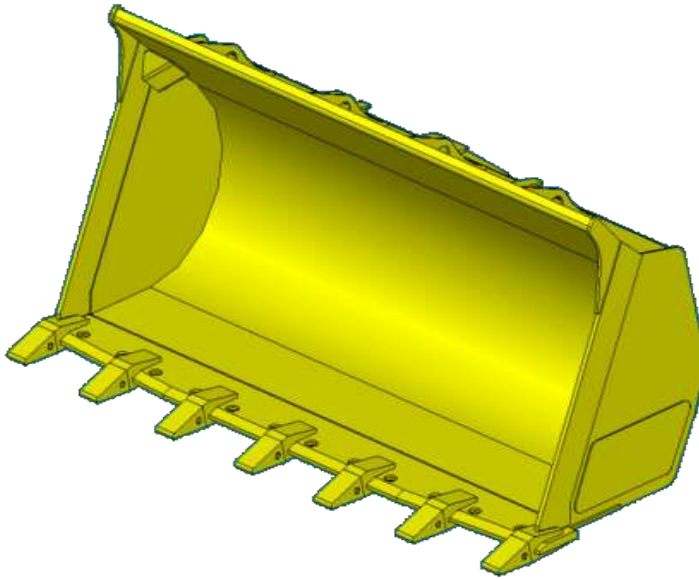

Feature:

- Standard bucket, bucket capacity 1.8 m³.
- Welding bucket teeth.

Benefit:

- Firm.
- Wear-resisting.

AVAILABILITY

PERFORMANCE

PRODUCTIVITY

OPERATOR ENVIRONMENT

OPERATING COST

SAFETY

SDLG LG936L

GP bucket (1.6)

E3623115A36
E3623115A29
E3626115A29

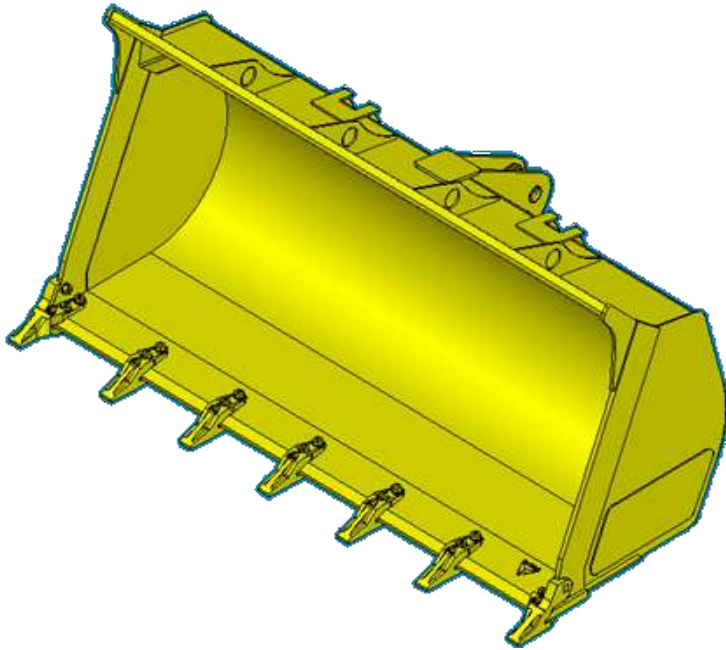

Feature:

- Standard bucket (Heightening product) , bucket capacity 1.6 m³.
- Bucket bottom thickening.

Benefit:

- Firm.
- Wear-resisting.

AVAILABILITY

PERFORMANCE

PRODUCTIVITY

OPERATOR ENVIRONMENT

OPERATING COST

SAFETY

SDLG LG936L

LM bucket

E3623115A36
E3623115A29
E3626115A29

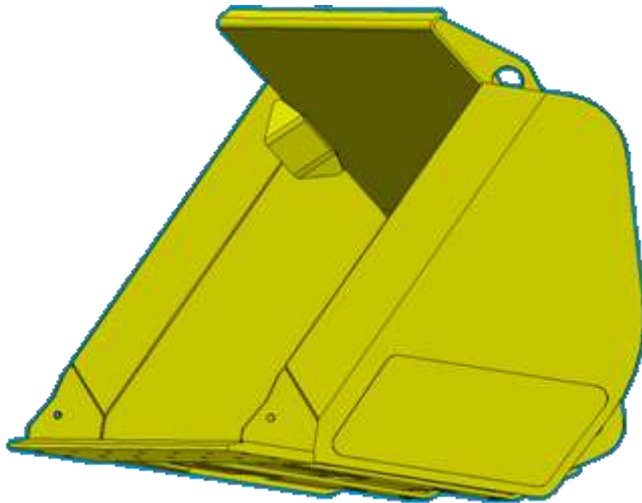

Feature:

- LM bucket , The back of the heightening design , bucket capacity 3.0 m³ .
- Bucket bottom thickening.

Benefit:

- Not easy scattering after full load.
- more wear-resisting and long service life.

AVAILABILITY



PERFORMANCE

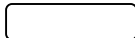

PRODUCTIVITY



OPERATOR ENVIRONMENT

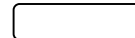

OPERATING COST

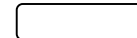

SAFETY



SDLG LG936L

LM bucket

E3623115A36
E3623115A29
E3626115A29

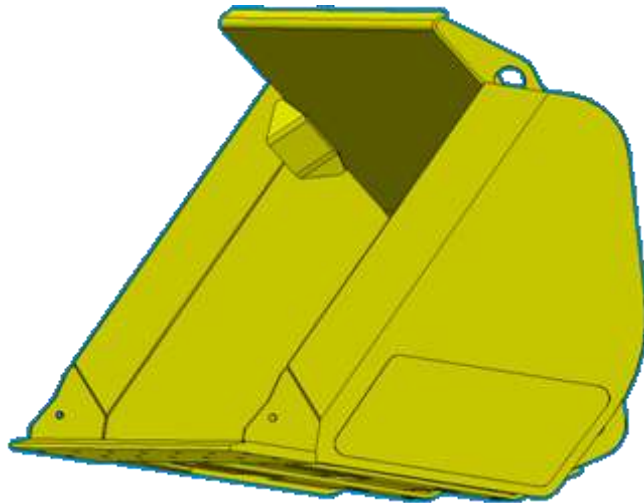

Feature:

- LM bucket , The back of the heightening design , bucket capacity 2.5 m³.
- Bucket bottom thickening.

Benefit:

- Not easy scattering after full load.
- more wear-resisting and long service life.

AVAILABILITY

PERFORMANCE

PRODUCTIVITY

OPERATOR ENVIRONMENT

OPERATING COST

SAFETY

SDLG LG936L

Rock bucket

E3623115A36
E3623115A29
E3626115A29

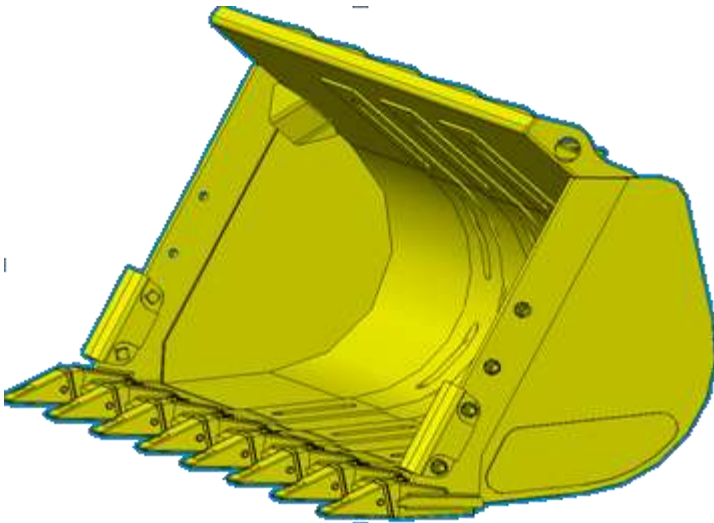

Feature:

- Make optimized design to strengthen the bucket by Lingong.
- Bucket capacity 1.5 m³.
- The butcher plate, wear-resisting plate adopt wear-resisting material.
- The bottom of the bucket and bucket side plate adopts flitch to strengthen.
- Bucket teeth with gear sleeve.

Benefit:

- Not easy scattering after full load because of high load coefficient.
- High quality materials and optimization of structure, more wear-resisting, long service life.

AVAILABILITY

PERFORMANCE

PRODUCTIVITY

OPERATOR ENVIRONMENT

OPERATING COST

SAFETY

SDLG LG936L

Rock bucket

E3623115A36

E3623115A29

E3626115A29

Feature:

- Make optimized design to strengthen the bucket by Lingong.
- Bucket capacity 1.5 m³.
- The butcher plate, wear-resisting plate adopt wear-resisting material.
- The bottom of the bucket and bucket side plate adopts flitch to strengthen.
- Bucket teeth with gear sleeve. Connected by bolt.

Benefit:

- Not easy scattering after full load because of high load coefficient.
- High quality materials and optimization of structure, more wear-resisting, long service life.
- Easy to change.

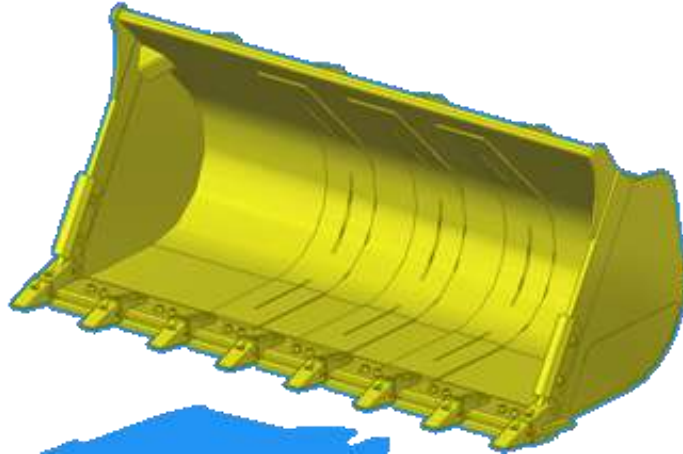

AVAILABILITY

PERFORMANCE

PRODUCTIVITY

OPERATOR ENVIRONMENT

OPERATING COST

SAFETY

SDLG LG936L

Multi-purpose bucket

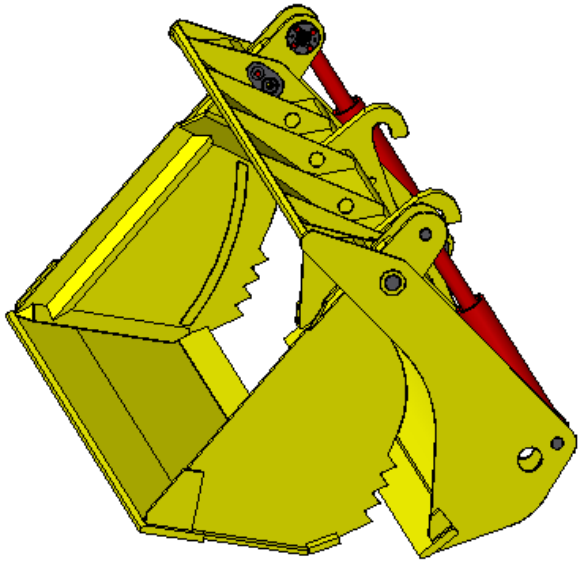

Feature:

- Bucket capacity of 1.8 m³.

Benefit:

- Suitable for operation under various working conditions.
- Used as common bucket.
- To load small amount of stem materials.
- To perform simple push operation.
- To use as high dumping bucket.

AVAILABILITY

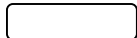

PERFORMANCE



PRODUCTIVITY



OPERATOR ENVIRONMENT

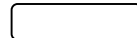

OPERATING COST



SAFETY



SDLG LG936L

Side dumping bucket

E3623115A36
E3623115A29
E3626115A29

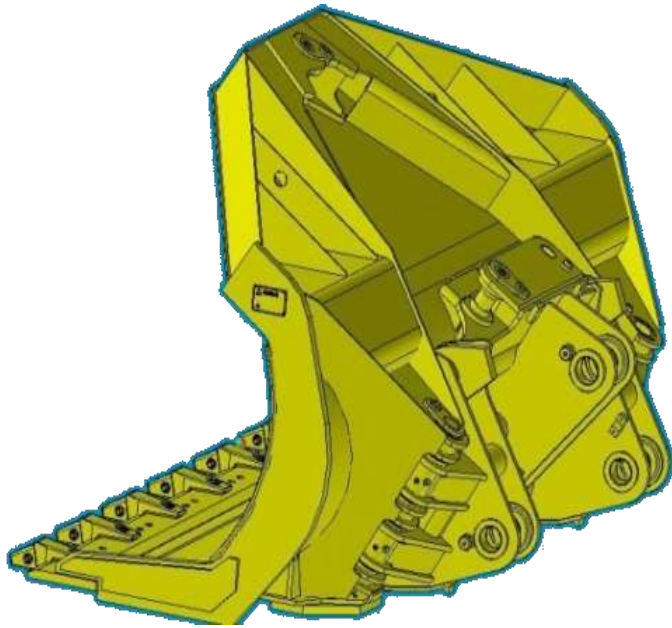

Feature:

- Bucket capacity of 1.4 m³.

Benefit:

- Mainly shovel the materials in the tunnel or other narrow sites.
- Strong and durable.
- Long service life.

AVAILABILITY



PERFORMANCE



PRODUCTIVITY

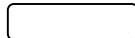

OPERATOR ENVIRONMENT

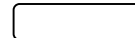

OPERATING COST



SAFETY

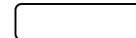

SDLG LG936L

Pallet Fork

E3623115A36
E3623115A29
E3626115A29

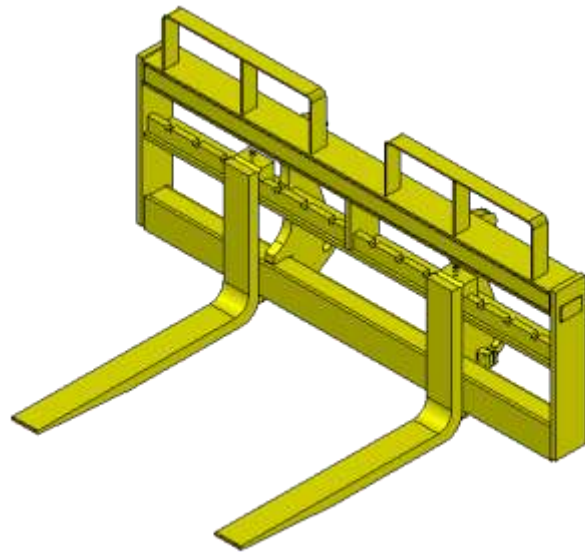

Feature:

- Pallet Fork.
- Effective length of prong:1800mm.
- Maximum width of two prongs outside:1700mm.
- The width between two prongs is adjustable.
- Max. dumping height:3531mm.
- Corresponding dumping distance:2613mm.

Benefit:

- Mainly to replace the forklift to perform fork loading of less translational motion requirement.
- Do some simple hoisting operation.

AVAILABILITY



PERFORMANCE



PRODUCTIVITY



OPERATOR ENVIRONMENT

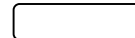

OPERATING COST



SAFETY



SDLG LG936L

Log grapple

E3623115A36
E3623115A29
E3626115A29

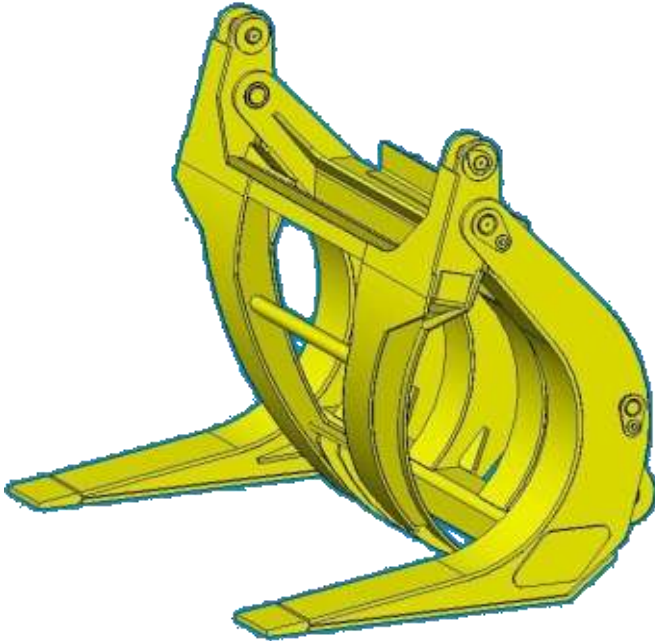

Feature:

- Log grapple.
- Width:1800mm , Opening:1590mm.

Benefit:

- Used for the loading of log ,stem and tubular long materials.Mainly to achieve the consistent action of upper fork.

AVAILABILITY

PERFORMANCE

PRODUCTIVITY

OPERATOR ENVIRONMENT

OPERATING COST

SAFETY

SDLG LG936L

Log grapple

E3623115A36
E3623115A29
E3626115A29

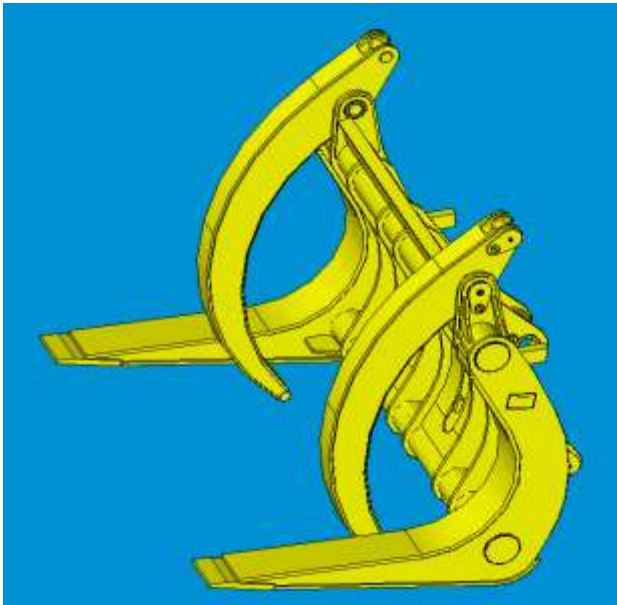

Feature:

- Log grapple.
- Width: 1923mm , Opening:1552mm.

Benefit:

- Bifurcation log grapple. Up and down forks do not cross.
- Is mainly used for the material that has different diameter for both side of it. For the condition that the two tooth will not the same action.

AVAILABILITY

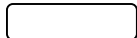

PERFORMANCE



PRODUCTIVITY



OPERATOR ENVIRONMENT

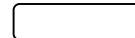

OPERATING COST



SAFETY

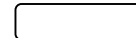

SDLG LG936L

Log grapple

E3623115A36
E3623115A29
E3626115A29

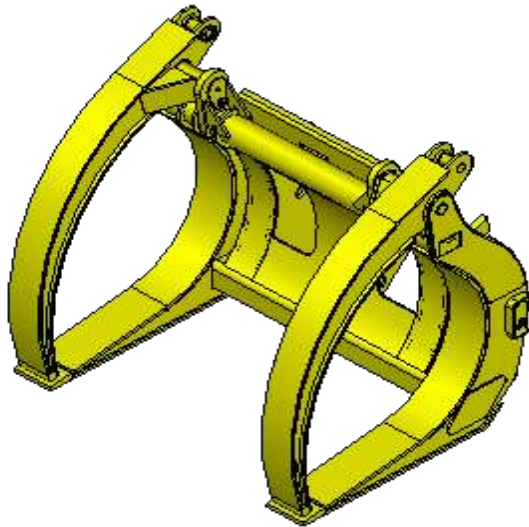

Feature:

- Log grapple.
- Width: 1700mm , Opening:1900mm.
- Minimum retaining diameter:944mm.

Benefit:

- Used for timber factory and wood processing factory to select wood clamping, the operation condition of the port is mainly used for the optional size of wood.

AVAILABILITY

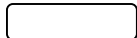

PERFORMANCE



PRODUCTIVITY

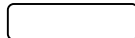

OPERATOR ENVIRONMENT

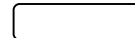

OPERATING COST



SAFETY



SDLG LG936L

Grass grapple

E3623115A36
E3623115A29
E3626115A29

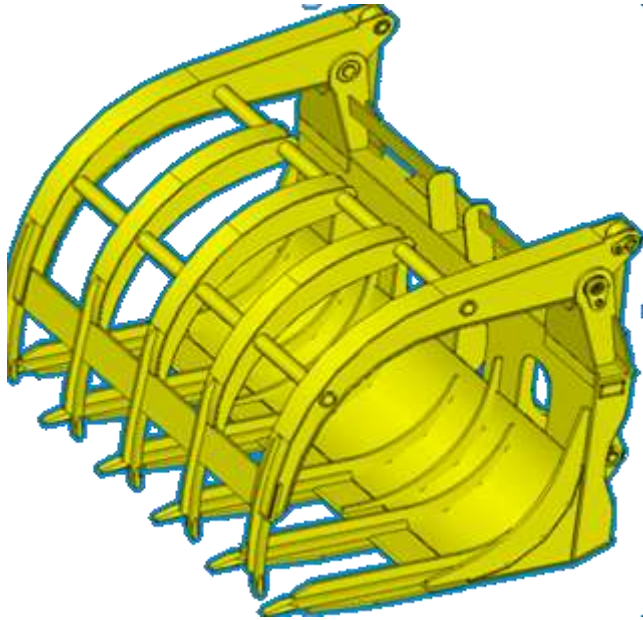

Feature:

- Grass grapple.
- Width:2400mm. Opening:2380mm)

Benefit:

- Used for the loading of forage in the paper mill.

AVAILABILITY



PERFORMANCE



PRODUCTIVITY

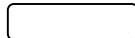

OPERATOR ENVIRONMENT

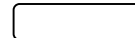

OPERATING COST



SAFETY

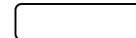

SDLG LG936L

Snow removal device

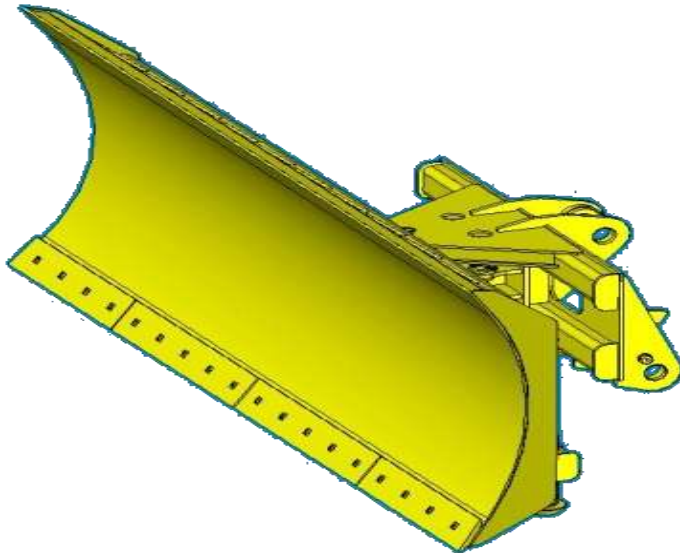
**Feature:**

- Light snow removal device.

Benefit:

- To pile the bulk materials for snow clearing.

AVAILABILITY

PERFORMANCE

PRODUCTIVITY

OPERATOR ENVIRONMENT

OPERATING COST

SAFETY

SDLG LG936L

Snow removal device

E3623115A36

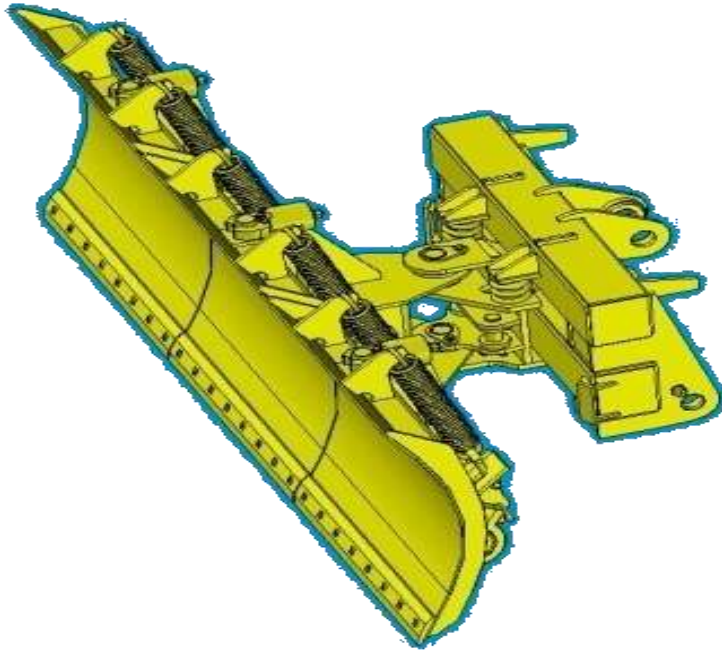
**Feature:**

- Heavy snow removal device.

Benefit:

- Mainly used to remove the thick snow

AVAILABILITY

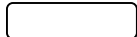

PERFORMANCE



PRODUCTIVITY

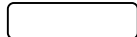

OPERATOR ENVIRONMENT

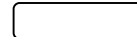

OPERATING COST



SAFETY

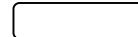

SDLG LG936L

Quick-change device

E3623115AK6
E3623115AK9
E3623115GK6

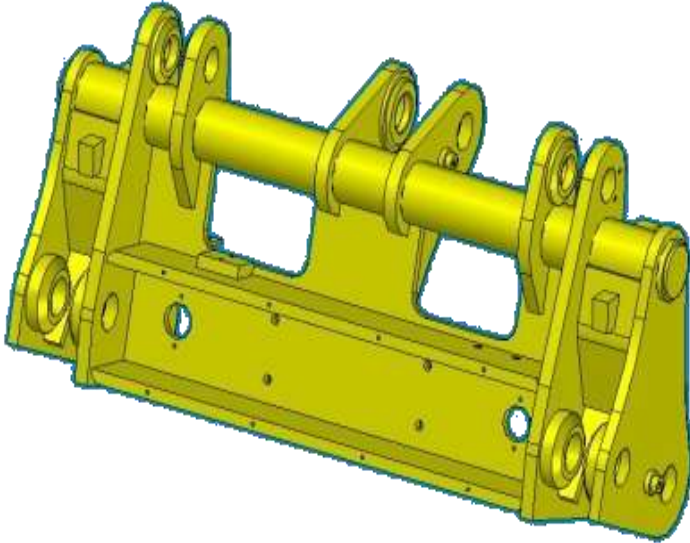

Feature:

- Quick-change device
- In accordance with ISO international standards.

Benefit:

- Widely used, multi-usage.
- Don't need to change, can directly replace the global brand quick-change attachment.

AVAILABILITY

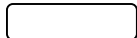

PERFORMANCE



PRODUCTIVITY



OPERATOR ENVIRONMENT

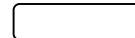

OPERATING COST



SAFETY



SDLG LG936L

Suitable for quick coupler attachments

E3623115AK6
E3623115AK9

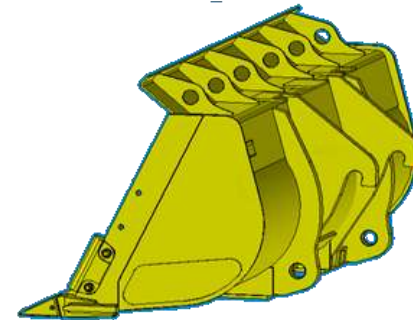
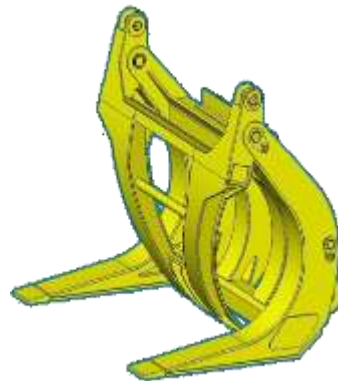
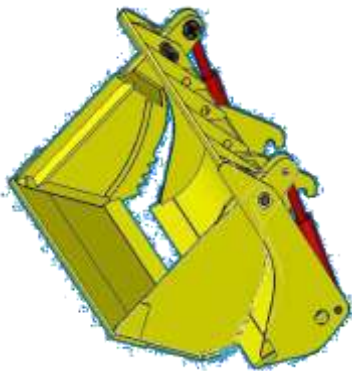
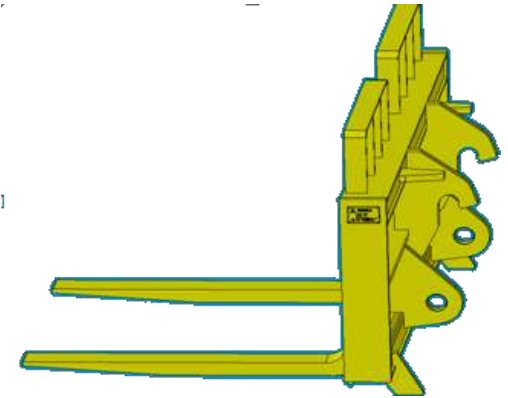
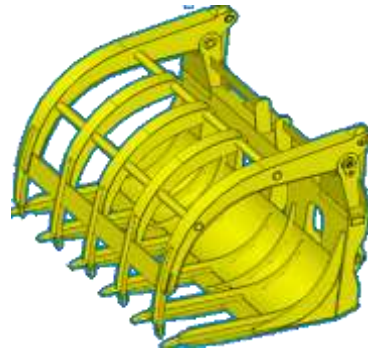
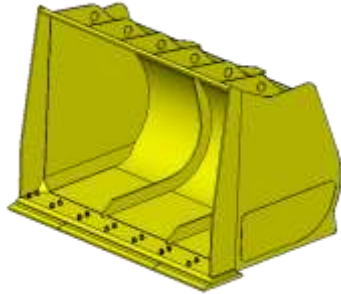
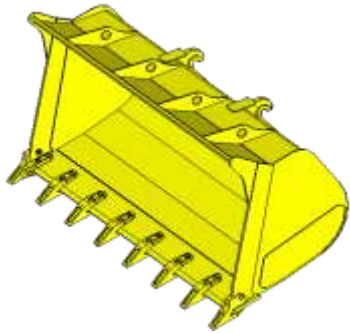

AVAILABILITY

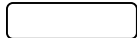

PERFORMANCE



PRODUCTIVITY



OPERATOR ENVIRONMENT



OPERATING COST



SAFETY

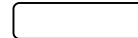

E3623115GK6

SDLG LG936L

Suitable for quick coupler attachments

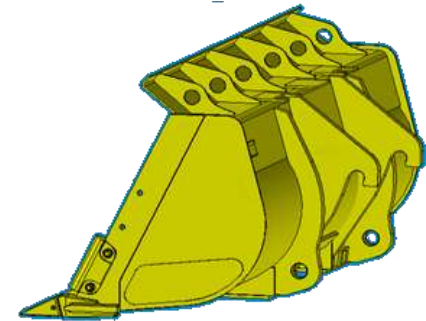
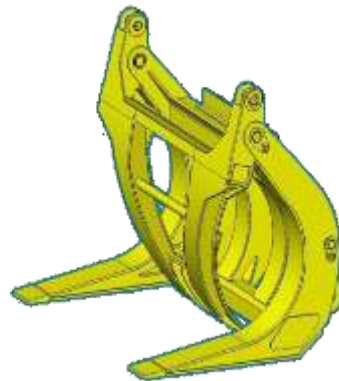
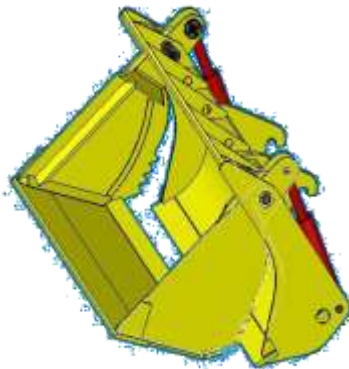
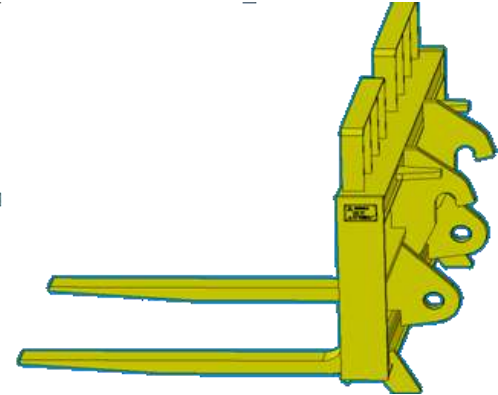
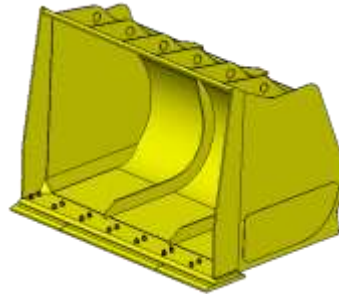
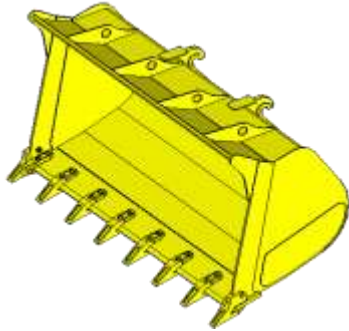

AVAILABILITY



PERFORMANCE



PRODUCTIVITY



OPERATOR ENVIRONMENT



OPERATING COST



SAFETY



Vision & Mission

Our Vision

To become the No.1 Chinese construction equipment brand for reliability, customer satisfaction and Brand image in the construction machinery industry.

Our Mission

To provide highly reliable products and services in order to maximize our value in the eyes of the customer.

Brand Promotion Slogan

Reliability in Action

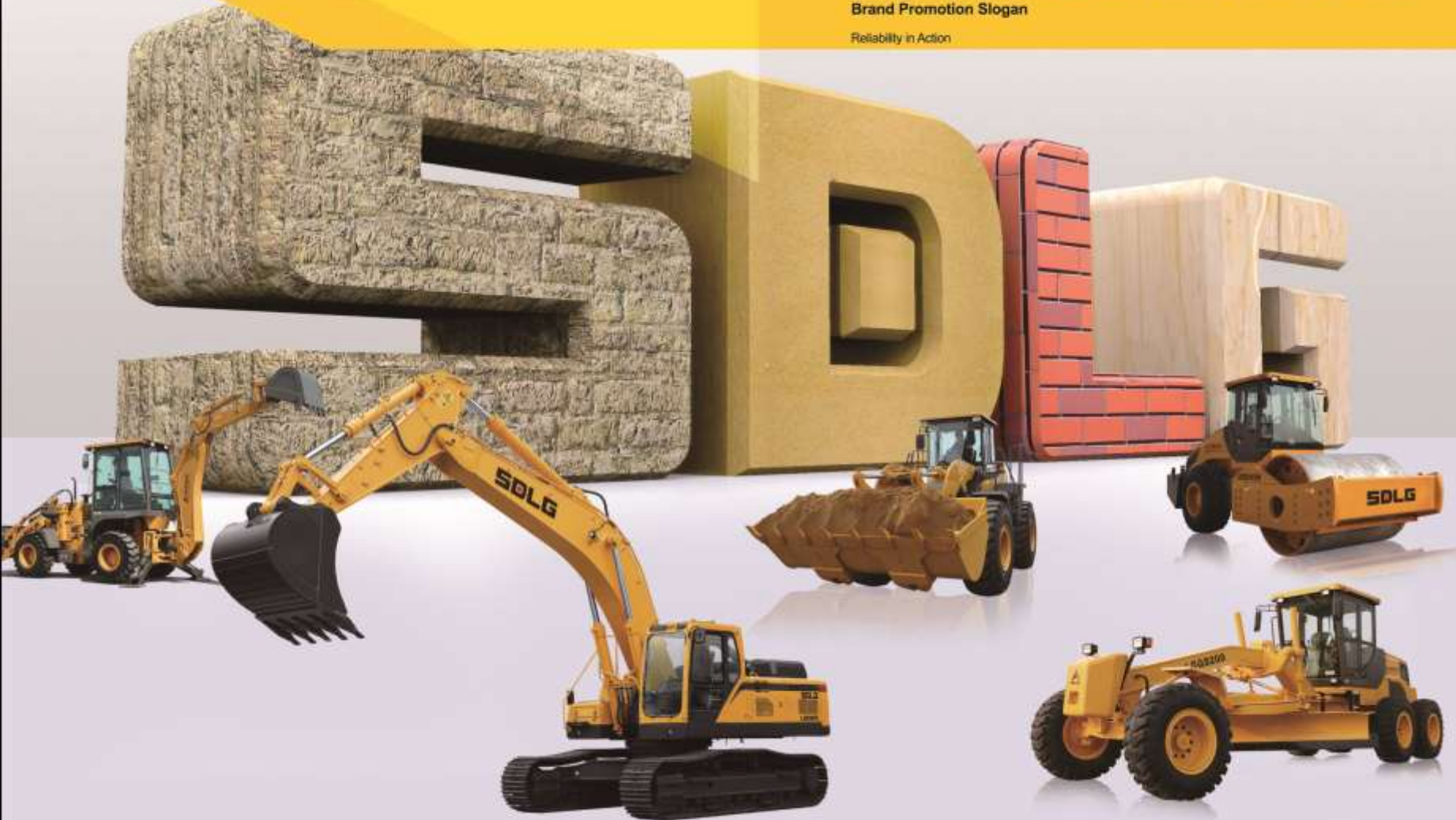

RELIABILITY IN ACTION

