

LG936L 轮式装载机维修手册
LG936L Wheel Loader
Service Manual



2938001999



CONTENTS

Safety and Environment	1
0 General	0-1
1 Service and Maintenance.....	1-1
11 Lubricant, Fuel and Other Liquids	1-1
12 Repair	1-5
2 Engine System.....	2-1
21 General	2-1
22 Lubrication System.....	2-6
23 Fuel Supply System.....	2-7
24 Cooling System	2-9
25 Intake and Exhaust System.....	2-11
26 Disassembly and Assembly of Engine	2-13
27 Disassembly and Assembly of Fuel Tank.....	2-36
28 Disassembly and Assembly of Radiator	2-41
29 Diagnosis and Troubleshooting of Engine System Common Faults	2-47
3Electrical and Information System	3-1
31 Description of Electrical System	3-1
32 Power Supply and Starting System	3-5
33 Instrument Monitoring System.....	3-20
34 Lighting System	3-24
35 Reverse Alarm System & Electric Horn System.....	3-27
36 Wiper and Cleaning System	3-29
37 Wiring Harness Routing	3-31
38 Fault Inspection and Diagnosis	3-41
4 Power Transmission Propulsion.....	4-1
41 Transmission Box System	4-2
42 Transmission Shaft System	4-29



43 Drive Axle System.....	4-35
44 Diagnosis and Solutions for Common Faults of Transmission System.....	4-44
5 Brake System	5-1
51 Service Brake System.....	5-2
52 Parking Brake System	5-23
53 Brake System Common Faults and Troubleshooting	5-27
6 Steering System	6-1
61 General	6-1
62 Description, Disassembly and Assembly of Main Components.....	6-5
63 Deflation of Steering System	6-26
64 Deflation of Steering System	6-29
65 Diagnosis and Solutions for Common Faults of Steering System.....	6-30
7 Frames, Wheels and Working Equipment	7-1
71 General	7-1
72 Disassembly and Assembly of Counterweight	7-4
73 Disassembly and Assembly of Working Device.....	7-5
74 Disassembly and Assembly of Frame Junction	7-15
75 Disassembly and Assembly of Tires.....	7-20
76 Current Maintenance for Frame, Tires and Working Device.....	7-21
8 Cab and Cover Systems	8-1
81 Cab Description.....	8-1
82 A/C System Description.....	8-4
83 Disassembly and Assembly of Cab Assembly.....	8-8
84 Disassembly and Assembly of Engine Hood.....	8-24
85 Disassembly of Left and Right Platform Assembly	8-29
86 Disassembly and Assembly of A/C System.....	8-32
87 Diagnosis and Solutions for Common Faults of A/C System.....	8-49
9 Working Hydraulic System	9-1
91 Components, Locations	9-1
92 Description of System Principle.....	9-2



93 Description, Disassembly and Assembly of Hydraulic System Components 9-5

94 Pressure Measuring Methods and Standards of Working Hydraulic System 9-46

95 Diagnosis and Solutions for Common Faults of Hydraulic System 9-48



Service Manual

LG936L

Version:0000



Safety

CONTENTS

Safety & Environment.....	1
Preface	1
Function Checking.....	2
Safety When Handling the Loader	3
Safety Regulations for Maintenance	6
General.....	7
Maintenance Position 1	9
Working under Elevated Boom	10
Fire Prevention Measures	10
Notes for Tire.....	12
Safety When Lifting and Supporting the Complete Machine	14
Methods for Front Axle	14
Methods for Rear Axle	15
Safety for Operation of the Battery	15
Starting with a Boosting Battery	17
Safety When Dealing with Oil and Fuel.....	18
Safety When Dealing with Refrigerant	19
Safety When Operating Accumulator (If installed)	21
The Safety of Hydraulic System.....	22
Checking after Experiencing a Fire or Heating	23
Health Hazard from Paint, Plastic and Rubber.....	24
Environment	27
Waste Disposal	27
Environmental Method.....	27
Environmentally Hazardous Liquids	29
Work in a Polluted Environment.....	29
Decontamination.....	30

Safety & Environment

Preface

This booklet is a part of **Service Manual for LG936L Wheel Loader**. Please carefully read this part.

WARNING

Be sure to read “Safety” part in the manual before operating.

Security Related to Everyone

You should always comply with the instructions in **Operation and Maintenance Manual for LG936L Wheel Loader**.

SDLG is aimed at the design and manufacture of safety and efficient machines. However, if the operators do not carefully read the safety instructions, or do not comply with these provisions or use wrong tools for this operation, then our efforts will be wasted.

To keep the functions of machine safely and effectively, you must always use the appropriate spare parts designed for this loader (SDLG original authentic parts). If you use unauthorized spare parts, we will not be responsible for the damage of the loader, and also offer the free repair and compensation.

Staff should be with strong safety consciousness, and keep the loader well-maintained. In this way we

cannot only realize safety and efficiency, but also produce profit.

If the operators do not comply with safety instructions, and do not pay attention to warning instructions in this manual, they should ensure their methods of operation are safe and reliable. Otherwise, there is the risk of accidents, and even leading casualties.

Function Checking

Please check the functions after safety-related electrical system operations are carried out, to ensure safety.

Safety-related electrical systems

Check the safety-related electrical system of the followings:

Parking brake

Service brake

Transmission box

Lifting function

Please refer to **Operation and Maintenance Manual for LG936L Wheel Loader** for details.

Safety When Handling the Loader

Shandong Lingong Construction Machinery Co., Ltd. is responsible only for the following conditions:

- Properly use and maintain the loaders based on the instructions described in **Service Manual for LG936L Wheel loader** and **Operation and Maintenance Manual for LG936L Wheel Loader**.
- Carry out the required examinations and checking in specified interval.
- Comply with the provisions about lubrication of the machine in the manual.
- No security seal is opened by unauthorized persons.
- All maintenance and repair work is carried out by the way defined by SDLG.
- Only use original authentic parts, accessories and attachments required by SDLG.

WARNING

Operation personnel must fully understand and master the contents in *Operation and Maintenance Manual for LG936L Wheel Loader* before operating the machine.

It is essential that drivers should carefully read *Operation and Maintenance Manual for LG936L Wheel Loader* and follow its instructions.

Untrained personnel to drive the loader may cause serious injury or death.

Do not operate the loader if *Operation and Maintenance Manual for LG936L Wheel Loader*

is not in place.

Be familiar with warning labels, symbols, and driving instructions on the machine before using it.

Several simple safety rules

- Resolve the safety problems and faults as soon as possible.
- Always wear protective items, such as helmet made of hard materials, safety glasses, gloves, boots, and security supplies for operation.
- When the engine is running, do not stand in front or rear of it.
- Ensure that the surface of the pedal, maintenance sites, handrails and anti-skidding parts are clean and without oil, diesel fuel, sludge and snow, etc., and ensure that if these parts are damaged or lost, timely replace and repair them.
- Check regularly whether all anti-skidding protection devices are secure. If not, firmly install or replace them.
- Always face the machine and use pedals and handrails when climbing on the machine. Always use the three-point contact, namely two hands and one foot, or two feet and one hand. Do not jump up and down!



Fig. 1 Entering/leaving the machine

Here are some important rules:

- Perform all safety inspection measures in **Operation and Maintenance Manual for LG936L Wheel Loader.**

⚠ WARNING

If you feel tired or influence of alcohol, drugs or affected by other drugs, do not



Fig. 2 Read **Operation and Maintenance Manual for LG936L Wheel Loader** before operating the machine

drive the machine.

- Before starting the engine, make sure there is adequate ventilation. The machine is equipped with diesel engine and the emission gas is harmful to your health. Therefore, do ensure adequate ventilation. If ventilation is insufficient, please avoid running the engine unless it is absolutely necessary.
- Before operation or maintenance on the machine, please read all signs and instructions as well as the contents in **Operation and Maintenance Manual for LG936L Wheel Loader**. Each sign contains information about safety, treatment and maintenance.
- Use the seat belt during operation.
- Always sit on the operator seat when starting the engine.
- Before the machine is used, make sure a ready for use, all functions should be intact and effective, and all the faults that may cause an accident should be ruled out.

Seat belt

- If the seat belt is worn, or the seat belt has been subjected to force when the machine has an accident, then this seat belt should be replaced immediately.
- Modifications on seat belt and mounting parts are absolutely prohibited.
- Seat belt is designed for only one adult, and it cannot be used for a couple of people.
- When the belt is not in use, it should always be in rolled-up state.

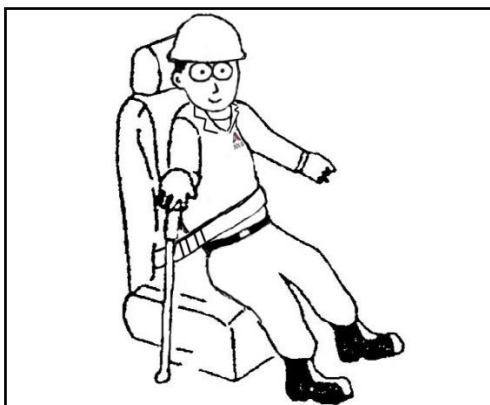

Fig. 3 Use the seat belt during operation

When the engine is running

- Pay attention to warning lights. For red one, apply immediate actions or pay special attention to it. Refer to the gauge part in **Operation and Maintenance Manual for LG936L Wheel Loader** for details.
- Before using the parking brake button, confirm attachment/attachment brackets have been placed on the ground.
- Be sure all the levers and handles are in the neutral position, and gear shifting handle is in the neutral position before leaving the machine.

WARNING

Risk of serious injury

- Do not stand near the hinged part between the front and rear frame, unless it is already locked with a locking lever frame.
- Before driving it on the road, empty the bucket.
- When leaving the machine and nobody watches it, it should be parked on level ground, and put the working device down on the ground, turn off the engine and remove the key.

When rollover danger is involved

For the cab with ROPS, if there is a risk of rollover, on the premise firmly fastened seat belt, and do grasp the wheel. Do not jump!

Cab emergency exits

The cab has two emergency exits, namely, the door and the right window.

Safety Regulations for Maintenance

This section includes the general safety rules about inspection and maintenance.

Other rules, information and warnings are offered in **Operation and Maintenance Manual for LG936L Wheel Loader**.

Incorrect maintenance may be very dangerous.

Before starting any maintenance work:

Make sure you have maintenance certificate, the correct information, the right tools and equipment in good condition to correctly perform maintenance work.

★ ATTENTION

Before mastering the correct knowledge about correct repair techniques and how to carry out maintenance on the machine, you are prohibited doing anything on the loader.

General

- If there is someone else to take over your maintenance work, ensure the person to get detailed information on the progress of work, how much has been done, and how much needs to be done.
- When you use high pressure tap to wash the machine, do not aim the nozzle directly at the coated anti-skipping surface or the signs attached on the vehicle.

⚠ WARNING

Step on special pedals when walking up and down the machine; refer to *Operation and Maintenance Manual for LG936L Wheel Loader*.

- When working on the machine, do not wear loose cloth that may be stuck, in order to avoid personal injury.
- Always wear protective caps, goggles, gloves,



Fig. 4 Do not step on the engine hood

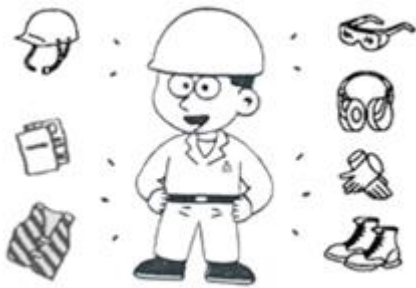

Fig. 5 Wear protective items

protective boots and other safety that your work needs.

- Always turn off the engine for maintenance unless the marking and signs of the vehicle or this manual have other instructions.
- Do not stand near the hinged frame, unless it is already locked with a locking lever frame.
- Before opening the engine cover, radiator tanks and similar parts, turn off the engine. Make sure that no tools or items that may cause damage left on the machine.
- When the engine is running and the machine is in operation, the engine cover should be kept closed.

Maintenance Position 1

Stop the machine on a level and hard surface, as shown in the following figure:

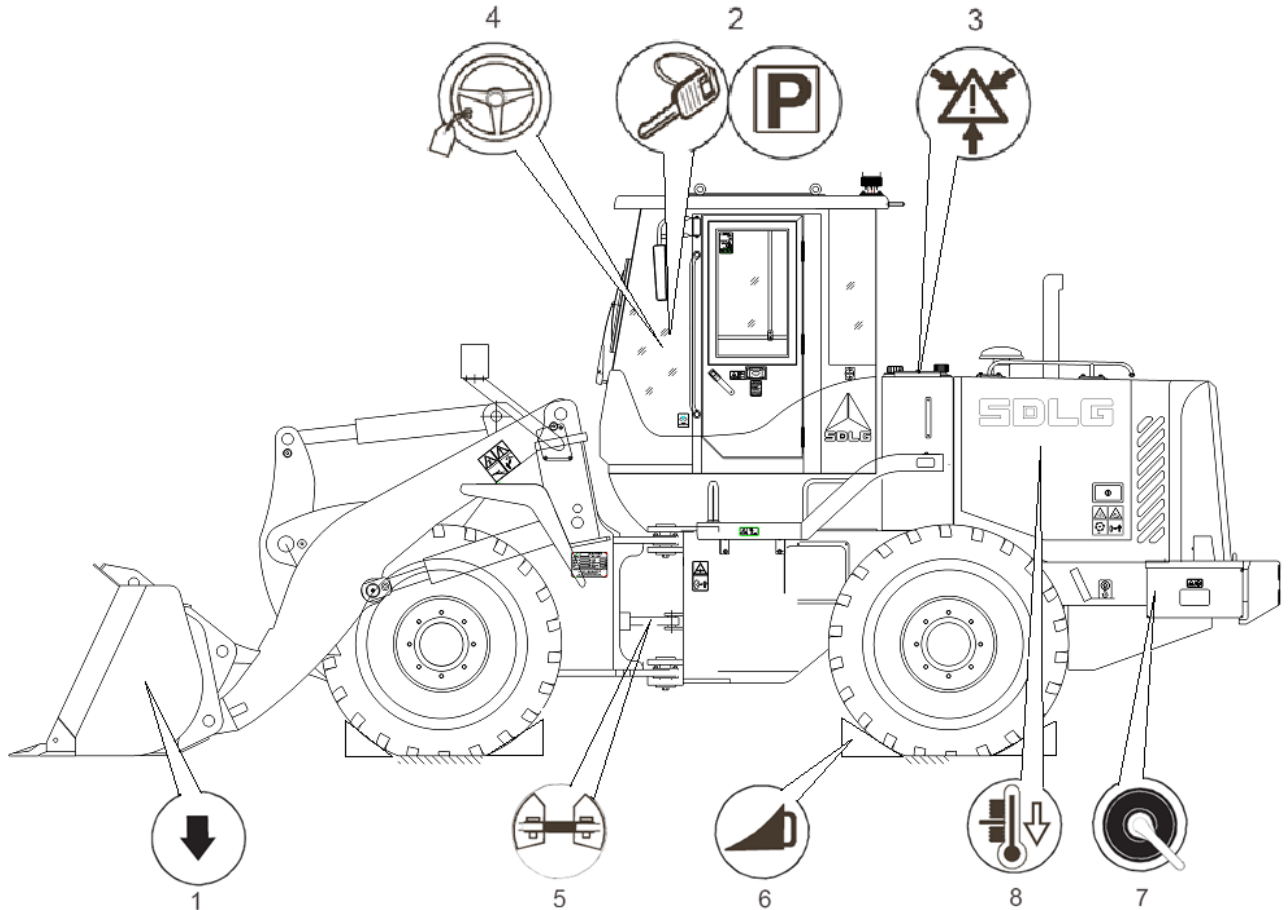

Fig.6 Maintenance position 1

1. Put attachments on the ground.
2. Turn off the engine and take down the ignition key.
3. Release the pressure in pressurized pipe and oil tank to prevent accidents.

WARNING

If the system pressure is not reduced before opening, oil will spray under high pressure, and may cause serious personal injury accidents.

4. The steering wheel should be connected with yellow black warning flag (a red warning flag may be used in the United States).
5. Make sure the frame lock lever is connected.
6. Press the parking brake button, so that the vehicle is in the parking brake status and wedge the loader.
7. Battery cut-off switch is off.

8. Let the machine cool down.

WARNING

If you have to operate on the machine before it is cooled down, pay attention to hot liquid and components, in order to avoid burns.

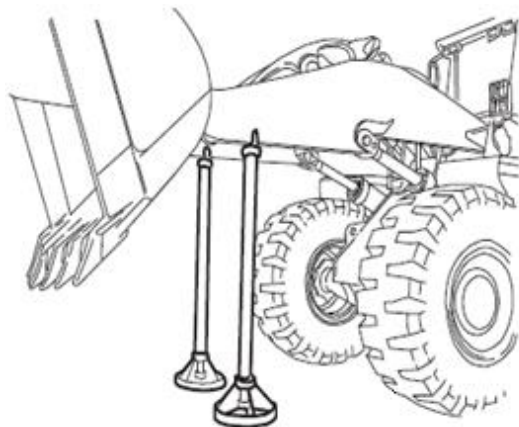

Fig. 7 Fix the boom firmly

Working under Elevated Boom

Before starting operation, always use the support frame. Support frame must be mounted on a sturdy and flat surface.

WARNING

Pay attention to the exact location of the support under the boom.

If the support is placed too forward, it will be overwhelmed when the attachment fixator tilts forward.

Fire Prevention Measures

- Even if only the fire may happen, if circumstances permit, and remember your personal safety, you can take the following measures:
 - Start the machine, leaving the fire or hazardous sites.
 - Lower the lift arm to its lowest position, so that the attachments stay on the ground.
 - Turn the ignition key to turn off the engine.
 - Leave the cab.
 - Disconnect the battery switch.
 - Start to put out the fire, and call for the fire department when necessary.
- When fill the machine with oil, or when the fuel is exposed to air, the machine should not be

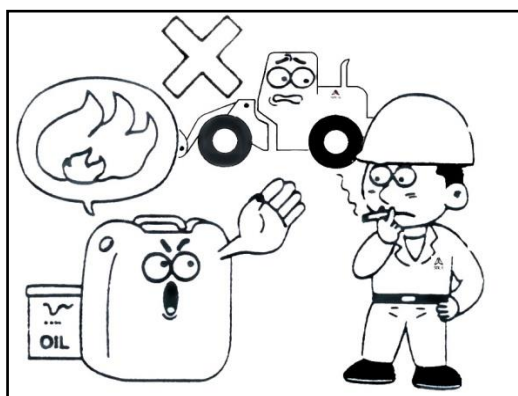

Fig. 8 When filling the fuel or the fuel is exposed to air, absolute prevention of fireworks is needed

near fireworks.

- Diesel fuel is flammable and cannot be used to clean the machine. Clean the machine with approved cleaning agent.
- Some cleaning agents may cause fire or irritate the skin. Do avoid absorbing vapors of cleaning agent.

Cleanliness

- Cleanliness is one of critical factors to keep safe and reliable operation of the system. Therefore, we should keep maintenance site clean.
- Make daily inspection of machinery and equipment to ensure no dust and oil, which may reduce the risk of fire, and easy to find defective parts or loose parts.

If cleaning with high pressure water, must be extremely careful, because the electronic components and cable insulation may be damaged at a relatively moderate pressure and water temperature. Please protect the cable.

Electrical system

- Check whether the cable is scratched, and ensure that the cable will not suffer such damage. This is particularly important for the cable without fuse. For example , the cables between the following components:
 - Battery
 - Battery – starter motor
 - Alternator – starter motor
 - Warm-up coils from cable to the engine.
- If the cable without fuse is ever disconnected, do check whether the wires are connected again, and make sure wire connections can greatly

prevent from being scratched. The cable without fuse cannot be close to oil or fuel hoses.

- For installing any optional equipment, be sure that all wires are connected through a fuse and make sure the layout of wiring and fixing of wire can avoid being scratched.

Fuel, hydraulic and brake system

- Check and make sure fuel, hydraulic and brake hoses are not scratched.

Welding and grinding

For carrying out any welding work, fire extinguisher must be readily available.

- Welding and grinding operations can only be carried on clean parts of the machine, and cannot be in a position with combustible liquids, such as fuel tanks and hydraulic pipe. If welding or grinding on such parts is inevitable, be especially careful.
- When welding on the paint surface, you should first remove the painting. Welding on the painting surface not only produces health harmful gases, but also cause poor welding or malfunction, resulting in accidents.
- Use personal protective equipment. If conditions are permitted, you can use the exhaust fan to drain the poisonous gas produced by the welding and grinding.

Notes for Tire

WARNING

When inflating the tires installed on a disconnect-type rim, explosion may occur, leading to serious injury.

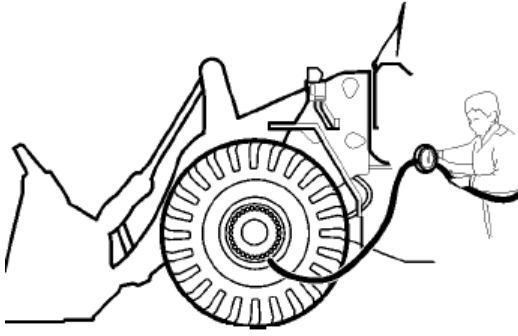

Fig. 9 Do not stand near tires when inflating

Inflation

- Do not stand near the wheel side when inflating the tires installed on a disconnect-type rim. When inflating, you can use the automatic locking air nozzle, and use a long enough hose so that you can stand outside the danger zone.
- When inflating the tires, verify that no person stands in danger zone.
- Check the tire pressure only when the loader is unloaded.
- Spare tire should be inflated only enough to maintain the rim parts in position.
- When the tires are inflated, use a box and a rope or chain to fix the loose wheels. Before removing the box, check whether the tire is correctly installed on the rim.
- After inflation, do not adjust the side ring or lock ring.
- If tire pressure installed on the machine is less than 80% of the normal pressure, and wheel rim or tire is damaged, you should remove the tire.

Install tires and rims

- Only trained technicians are allowed to handle the tires.
- Before removing the tire from the rim, you should deflate tire firstly.
- If the tire and the rim do not match with each other, you cannot install the tire on the rim.
- Do not install rims parts with different sizes together, and do not use damaged and failed components.
- If you use the repaired wheel assembly, be

very careful. Failed or incorrect welding, heating or fusing may damage the strength of component, resulting in failure of the future.

- Before installing the lock ring, you should confirm the lock ring in the rim groove free of dirt and dust.
- When installing the tire on the rim, use the lubricant recommended by the tire manufacturer.

Repair tires and wheel rings

- Do not cut, weld or heat the wheel assembly in any way.
- Be careful to use wheel rim remover and hydraulic jacks. When removing impurities from the tires, stand outside the danger zone. It is extremely dangerous to loosen the rim remover, which may cause serious personal injury and death.

Safety When Lifting and Supporting the Complete Machine

Place the machine on the maintenance position, and always use the jacks and support equipment with sufficient bearing capacity.

Other works must be carried out after the front and rear axles are supported in a safety way.

WARNING

When the machine is only supported by jack, it is prohibited to entering the machine or walking under the machine.

When replacing tires and brakes, always keep operating on one axle a time.

Methods for Front Axle

Lift the machine by operating the working equipment, and then use special tools to support it.

Methods for Rear Axle

After jacking up the machine with a jack, support the counterweight with special tooling and put wood block between the axle and the frame to prevent the swing of rear axle.

★ ATTENTION

Before falling down the machine, do not forget to remove the wood block.

Machine must be supported by tooling and jacks with sufficient bearing capacity.

In the case that two wheels are lifted, you can more easily rotate the hub to set the wheel nut in place.

Safety for Operation of the Battery

⚠ WARNING

Serious risk of corrosion!

Battery contains sulfuric acid, and is extremely corrosive for loader parts and the human body.

As to all the work involved in vehicle battery, the mixture of explosive gases and corrosive sulfuric acid will greatly increase the risk of accidents.

Therefore, when you operate the battery, you should carefully read and follow these rules.

For operation the battery, please follow these instructions:

- Battery will release explosive gases. Do not smoke near the battery.
- Before removing the battery, firstly disconnect the ground wire. To reduce the risk of fire hazards, when installing the battery, connect



Fig. 10 Corrosive sulfuric acid

the ground wire at last.

- Do not tilt the battery in any direction. Battery electrolyte may leak.
- Do not connect the discharged battery and fully charged batteries in series. It will be with the risk of explosion.
- Do not allow metal objects (such as tools, rings, watches) contact with the battery terminals. It is with risk of fire and personal injury.
- When working near the battery, cover the top of the battery with cloth or other non-conductive material.
- Always install the caps of battery terminal.
- Battery includes substances harmful to health and the environment. Therefore, disused batteries must be dealt with in accordance with local/national regulations.

Battery charging

Risk of explosion

Explosive oxyhydrogen mixtures will be produced during charging. So any short circuit, open flame or sparks near battery can cause powerful explosion. Before disconnecting the charging clamps, always turn off the charging current. Keep it ventilated, especially charging in an enclosed space.



WARNING

Serious risk of corrosion!

Corrosive sulfuric acid

Battery electrolyte includes corrosive sulfuric acid. If electrolyte is splashed on exposed skin, you should immediately wash it away. Clean the affected area with soap and plenty of water. If electrolyte gets into your eyes, or any other

sensitive parts of the body, immediately flush it with water and seek help for doctor.

Starting with a Boosting Battery

★ ATTENTION

Check and make sure that the voltage of battery pack and any other step-up power supply are same.

⚠ WARNING

If a fully charged battery is connected to a depleted battery, the battery may be burst open due to power surges, it may cause personal injury accidents.

Follow these steps when starting with a booster:

1. Open the engine hood.
2. Open the battery cover.
3. Turn off the battery switch.
4. Do not disconnect the machine's battery cables.
5. Remove the caps from the battery terminal.
6. Connect the positive cable boosting battery or other power source to positive terminal of the battery.
7. Connect the negative cable boosting battery to the engine block.
8. Turn on the battery switch.
9. Use the ignition switch in the cab to start the engine.
10. For charging the boosting battery with the alternator, firstly remove the jumper starter cable from the negative terminal of boost battery and the ground. Then remove the jumper starter cable between the positive

terminals.

★ ATTENTION

If the alternator is not charging, use switch to turn off the machine and check the reason.

11. Recover the machine.

Safety When Dealing with Oil and Fuel

⚠ WARNING

Risk of scalding! Use protective gloves.

- Replace hydraulic oil inside the engine and transmission, remember that the oil is very hot and may cause burns/scalds.
- Engine and gearbox oil, hydraulic oil and diesel fuel are corrosive for the mucous membranes, such as the eyes, throat and skin. So be especially careful to keep these sensitive parts of the body away from the oil.
- For evacuation or discharge oil or fuel, do take measures to avoid unnecessary spilling. In a place that is impossible to use the container to collect the oil, use an absorbing pump or hose as security measures. Casually releasing oil and fuel is not only harmful to the environment, but also cause fire.
- Waste oil should be handled by an authorized company.
- Remember that fire hazards!

Safety When Dealing with Refrigerant

Overview

Before turning on the air-conditioning system, repair work and further work should be carried out by personnel with special qualifications. Many countries also require that the repair person should be specially trained and officially recognized. Understand the regulations and comply with them in the country.

Refrigerant R134a is used for the air conditioning unit.

Type and filling amount of refrigerant are marked on the labels.

★ ATTENTION

R134a will aggravate the greenhouse effect, and don't expose it to the air intentionally.

Person protective equipment

When there is a danger of skin exposure to refrigerant, please use: tight goggles and protective gloves, and protect other exposed skin (frostbite hazard).

Danger

⚠ WARNING

These gases are odorless and tasteless; even it can cause serious damage to the lungs at low concentrations.

If it is not handled correctly, R134a refrigerant can cause serious personal injury and environmental hazards. Therefore, be very careful when operating the air conditioning unit! In order to avoid injury to personal in touch with refrigerant, the rules given



Fig. 11 When a risk of touching refrigerator is involved, do wear protective goggles and gloves

below will be of great help:

 **WARNING**

There is a danger of frostbite! Use protective gloves.

- Liquid refrigerant can cause frostbite.
- Low-concentration gaseous refrigerant has a certain impact, especially on the nervous system.
- The high-concentration gaseous refrigerant has anesthetic effect.
- Air conditioning units are of high pressure, and the refrigerant will inadvertently leak. Do not disconnect the hose or remove oil filling plug on the compressor.

If you suspect the leakage of some parts, you should contact with an authorized repair station approved and trained personnel to troubleshoot and repair it.

- Refrigerant gas is heavier than air and it will sink to the ground. Therefore, ensure that any escaping gas should be released before you start working.

In the working site during operation of refrigerant, smoking, welding or other open flames are not permitted. Refrigerant gas will burn and form a toxic gas. And it is very dangerous to breathe it. The gas formed by heating the refrigerant is pungent at high concentration.

Symptoms may appear after being exposed to the gas after a few hours (Maybe up to 24 hours).

Actions taken when the accident occurs

Inhale

If you suspect any as leakage, please leave

immediately, and try to find fresh air and move affected persons out of the danger zone. A small amount of refrigerant R134a vapor will have a certain impact, particularly on the nervous system. When the amount of the gas is large, the gas will have anesthetic effect. In serious cases, seek for immediate medical attention.

Skin contact

If frostbite occurs, rinse with warm water. If unprotected skin contacts with large amounts of liquid refrigerant, keep the damage zone warm with warm cloth or warm water. If the symptoms persist, seek for immediate medical.

Splashing into the eyes

Rinse the damaged zone with warm water until stimulation feeling disappears. Seek for medical help immediately.

Safety When Operating Accumulator (If installed)

Only qualified service personnel are allowed to operate.

WARNING

If the pressure is not reduced before open it, oil will spray under high pressure and cause serious injury.

Before removing the accumulator from the machine, the system should be depressurized.

Even some accumulators are removed from the machine, they still contain pressure, that is so-called pre-charge pressure. Therefore, be very careful in dealing with accumulator and operating on the accumulator.

When taking any measures on the accumulator, the pre-charge pressure must be reduced to atmospheric pressure.

Avoid exposing the accumulator to high temperature, do not handle roughly.

WARNING

Discarded accumulator without perforation may still contain high-pressure, be always extremely careful to handle it.

The pressure in scrapped accumulator should be released before being crushed, in order to avoid explosion.

The Safety of Hydraulic System

Loader hydraulic system runs at very high pressure. To avoid serious personal injury, it is very important to repair the system in the right way, and all personnel that contact with the machine should be very careful in their work, and pay close attention to any deficiencies.

To avoid accidents, please comply with the following requirements.

General

- The pressure of pressure limiting valve must not be adjusted to the value higher than the level recommended by the manufacturer.
- Bulgy hydraulic hose (for example, at the joint) may crack, so replace the hose as soon as possible! Note the leakage condition of hydraulic hoses and connections. Repair the parts before rupture!
- Discarded accumulator should be pierced before disposal to prevent explosions.

 **WARNING**

If the system pressure does not reduce, oil will spray under high pressure and cause serious injury.

Release the pressure (pressure relief)

After engine is shut down, there will be pressure left in system. Before loosening or opening hose connectors, plugs, etc. in hydraulic system or braking system, you must release the pressure of the system.

If the engine is stopped, release the pressure of the accumulator by moving the lift lever back and forth several times.

- All pressurized tanks/containers should be opened carefully to release any remaining pressure.
- Only after the system is fully relieved can you check whether leakage pipes and connections are tightened.

 **WARNING**

Leaked hydraulic hoses under high pressure may cause serious injury. The spilled liquid is very penetrating on the exposed skin.

- When checking leakage, check it with steel or cardboard, and do not use hand.

Checking after Experiencing a Fire or Heating

- As a precaution, the sealing ring (O-ring or an axle/shaft seals) should always be dealt with as made of the fluorine rubber, and refer to "fluorine rubber" part.

 **WARNING**

When washing burned machine, avoid splashing with water! Therefore, do not clean with high-pressure liquid.

- If there is a chance that the burnt parts may be exposed to melt polymer, do not directly touch them with hands. Wash it with plenty of lime water (a kind of solution or suspension of calcium hydroxide, namely slaked lime).
- Use thick protective rubber gloves and goggles to protect your eyes.
- If your skin may be exposed to burnt fluorine rubber, seek for medical help. The skin should be treated with anti-hydrofluoric-acid burnt cream or similar drugs. Symptoms may appear a few hours later after touching fluorine rubber.
- Discard protective gloves, cloth, and other items that may be exposed to fluorine burnt rubber.
- During operations, maintain good ventilation.
- If the eyes are hurt, rinse them immediately with plenty of water for at least 15 minutes. Then seek for medical treatment.

Health Hazard from Paint, Plastic and Rubber

Working on the paint surface

Do not weld or cut on paint surface. All paints after heating will decompose and produce a large amount of different substances, and it is very harmful to health if exposing in such an environment frequently.

Take the following security measures:

- Remove the paint on 10cm (4 in) area around working point with abrasive paper (use respirator mask).

If the paint cannot be sanded off, it should be removed by other methods, such as using paint remover.

★ ATTENTION

If the paint is removed with agent, use an exhaust fan, and wear a respirator mask and protective gloves.

- The grinding machine with high-speed disc will heat the paint and it can only be used for paint removing when an exhaust fan is placed. And wear a mask or other respiratory protection equipment at the same time.

Rubber and plastics

WARNING

Heated rubber and plastic will emit substances harmful to health and the environment.

Must observe the following safety rules:

- Without insulation measures taken in advance, do not weld or cut near polyester material (plastic or rubber) with a flamethrower.
- Do not burn polymeric materials when scraping them.
- After a fire or heating, the machine should be handled carefully.
- Always use gloves, goggles and face shields, or other respiratory protective equipment.

Fluoride rubber

WARNING

Serious risk of corrosion!

 **WARNING**

Hydrofluoric gas will be produced when heating the fluoride rubber and it may cause severe corrosion of the respiratory tract after breathing this gas.

Some seals are designed to withstand high temperatures (i.e. the seals in the engine, gearbox, axle, brake, hydraulic motors and pumps member), which are made of fluoride rubber, and they will generate hydrogen fluoride and Hydrofluoric acid when heated to high temperature.

Hydrofluoric acid is strongly acidic and corrosive, and it cannot be washed from the skin. And it would cause very serious burning and corrosion damage, and it takes a long time to recover. As a general principle, the injured tissue must be surgically removed.

Hydrofluoric acid will remain on the machine parts after the fire for long time (several years).

 **ATTENTION**

After contacting with hydrofluoric acid, the symptoms may appear after a few hours.

If swelling, redness or burning happens due to contacting with heated fluoride rubber, immediately seek for medical advice.

If the machine or machine parts suffered a fire or other intense heating, it can only be handled by trained service personnel.

When operate a machined suffered a fire, be sure to wear gloves made of strong rubber and effective safety goggles.

 **WARNING**

Burning painted, plastic or rubber parts will be

harmful to health.

Decontamination

For the area subjected to heating, if you suspect it is made of fluorine rubber, use a lot of lime water (calcium hydroxide, blended hydrated lime) to thoroughly wash it to remove toxic substances. After the decontamination, gloves must also be cleaned in lime water, and then scrap it.

Environment

Waste Disposal

For the treatment of waste, comply with the following steps.

REUSE is best method from an environmental point of view.

MATERIAL RECYCLING is also a good environmental choice of means for use of new products.

ENERGY RECOVERY is a good alternative to burn it as combustible materials when recycling it is impossible.

DESTRUCTION can be used in hazardous waste. Destruction must be operated in a special place.

DEPOSITION is the worst way from an environmental point of view, and should be avoided.

STORAGE is a temporary measure and deal with it until a suitable recycling technology is developed.

Environmental Method

Always select a most suitable method for environmental protection as long as there is a possibility, for example, use biological oil.



Fig. 12

Always comply with national and local environmental regulations.

All waste should be handed over to authorized waste disposal company.

Liquid and oil

Do not reuse the old liquid oil, such as coolant, and collect it in sealed container and leave it to destroy department.

Filter

Oil and fuel filter should be drained and then placed in a sealed container and then leave it to destroy department.

Refrigerant R134a

Refrigerant R134a contains substances affecting greenhouse effect and should not be released into the atmosphere. Recycle it.

Battery



WARNING

Serious risk of corrosion!

Batteries contain environmentally harmful substances and corrosive sulfuric acid. And should be handed over to recycling department.

Chemicals

Chemicals, paints, adhesives, detergents, etc., should be left to recycling department for disposal or destroy.

Rubber and plastics

Rubber and plastic parts should not be burned, and should be handed over to recycling department.

Tires should be based on special provisions to deal with.

Electronic components

Electrical and electronic waste parts, such as circuit boards, bulbs, should be handed over to recycling department.

Environmentally Hazardous Liquids

Note whether fuel, oil and other fluids harmful to the environment leak from the machine.

Take appropriate measures immediately to prevent leakage, and eliminate the pollution of contaminated sites as soon as possible.

Oil and fuel

When emptying or draining the oil and fuel, take appropriate measures to prevent unnecessary spilling. If a container cannot be used, use a pump or hose.

Air conditioning unit

Refrigerant R134a contains substances affecting greenhouse effect and should not be released into the atmosphere.

The personnel in charge of refrigerant maintenance must not only understand the country's relevant laws/regulations, but also understand the international rules.

Recommend that all maintenance for the air conditioning must first be trained. Many countries require the man with a certificate of authority can perform such operation.

Work in a Polluted Environment

When operate the machine in a polluted/unhealthy site, special devices for operating in such environments should be equipped with.

After operating in the environment with asbestos or other toxic dust, used cab and engine air filter must

be placed in sealed plastic bags (packed new filter bag), and leave them to the destruction department.

Decontamination

Clean the contamination up as soon as possible. Certain substances will soon be scattered into the environment.

Clean-up after the leakage/spilling

Use suitable absorbent material to collect leaking oil or fuel, such as absorbent pads.

Prevent leaked oil/fuel discharged into sewer with the rain/flood.

Contaminated soil and materials on the ground must be removed and collected in a suitable container.

Collected soil and absorbent material should be left to the destruction department.

Clean-up after the accident

If possible, seal up the leakage of the machine.

Use drainage barriers to isolate the leakage site.

Add the absorption material, such as sand or sawdust water.

Prevent leakage of liquid so that leaked oil/fuel will not discharge into sewers with the rain/floods.

Collect absorbent material and dirt floating layer in a sealed container, and leave them to the destruction department.

Clean up after the fire

First put out fire.

Deal with it in accordance with the post-accident clean-up measures.

★ ATTENTION

Be careful of the toxicity of certain substances after ignited.



Service Manual

LG936L

Version:0010



0 Introduction

CONTENTS

0	General.....	0-1
01	Product Introduction	0-1
011	Machine Appearance and Its Components Name	0-1
012	Overall Dimensions and Parameters	0-2
013	Product Model Composition and Significance.....	0-3
014	Use Conditions	0-3
015	Main Technical Parameters	0-4
02	Specification	0-6
03	Tools	0-11
04	Marks	0-12
05	Maintenance and Replacement Criteria.....	0-13
051	Visual Inspection or Hand Touching.....	0-13
052	Measure	0-14

0 General

01 Product Introduction

011 Machine Appearance and Its Components Name



Fig. 0-1

1 Bucket

2 Link mechanism

3 Front tire

4 Rear frame

5 Cab

6 Rear tire

7 Engine hood

8 Counterweight

012 Overall Dimensions and Parameters

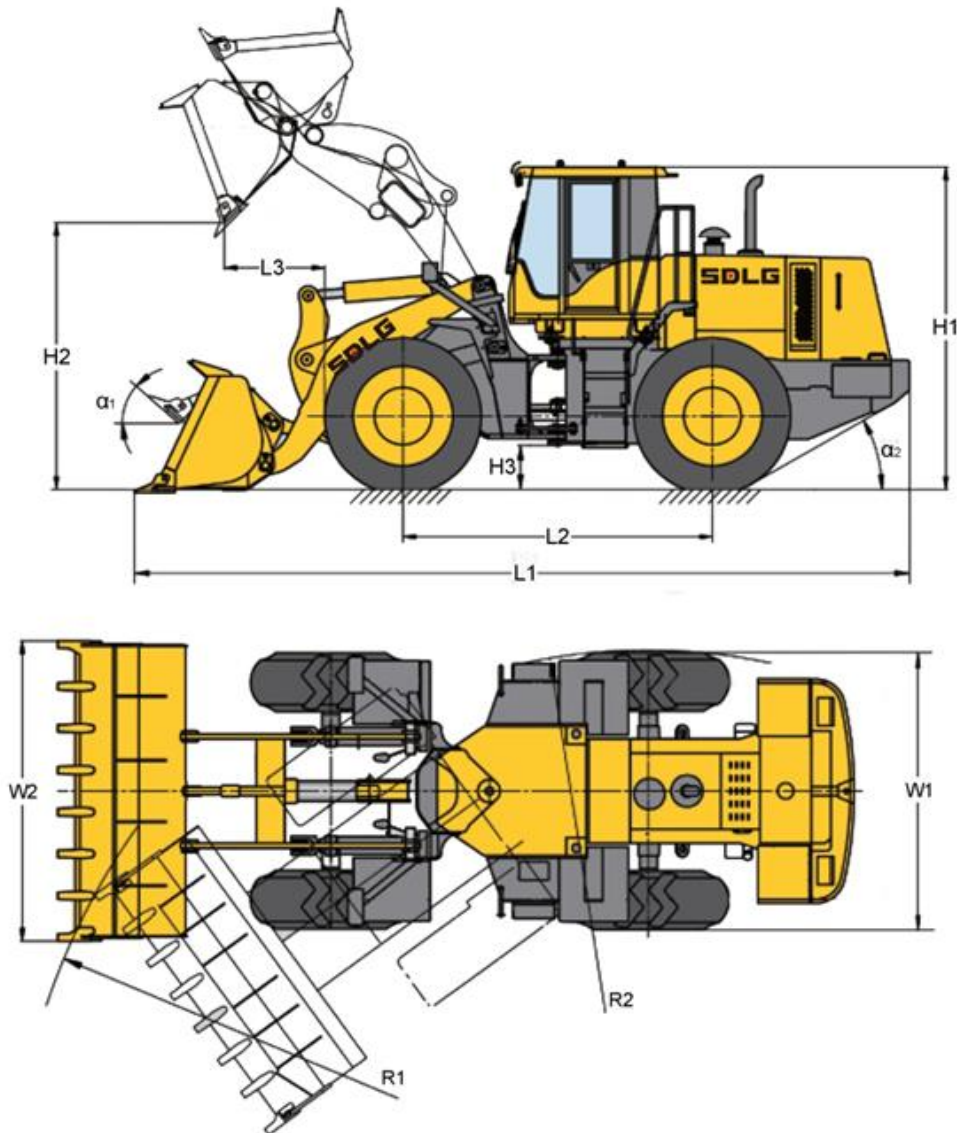
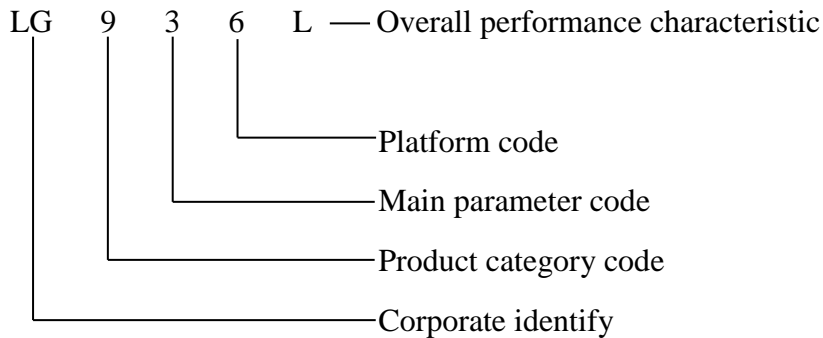

Fig. 0-2

Items (unit: mm)	Parameters	Items (unit: mm)	Parameters
Overall Length L1	7100	Wheel base L2	2850
Width (external part of wheel) W1	2310	Bucket width W2	2510
Height H1	3170	Min. ground clearance H3	370
Max. dump Height H2 (-45° dump angle)	2804	Moving levelly radius R1 (outside of bucket)	5912
Corresponding unloading distance L3 (-45° dump angle)	1198	Mini. steering radius R2 (outside of rear wheel)	5381

013 Product Model Composition and Significance



014 Use Conditions

The loader is featured with single bucket, unloading front, hinge joint and wheel type, a large construction machinery mainly for shoveling and loading of bulk materials. It is widely used in mineral yards, construction, roads, freight yards and ports, mainly for shoveling and short distance transport of bulk materials, such as loosened soil, sandy soil, dinas, coal and garbage. It can be used for dragging, flattening the ground, piling and stacking operations. Definitely it is a kind of multifunctional, efficient construction machinery.

015 Main Technical Parameters

Table 0-1 Overall performance parameters

Items	Parameters	Items	Parameters		
Rated operating load (kg)	3000	Operating Weight	10935		
Bucket capacity (m ³)	1.8	Number of shafts	2		
Max. dragging force (provided by engine) (kN)	≥105	Max. breakout force (kN)	≥92		
Tipping load (kN)	≥66	Max. climbing angle (°)	30		
Speed	Gears	I	II	III	IV
	Forward (km/h)	13	38	---	---
	Reverse (km/h)	17	---	---	---

Table 0-2 Engine parameters

Items	Parameters	Items	Parameters
Model	WP6G125E22	Number of cylinder	6
Rated power (kW)	92	Min fuel consumption (g/kWh)	215
Rated speed (r/min)	2200	Max torque (Nm)	500

Table 0-3 Transmission

Items		Parameter/contents	
Torque converter	Inlet pressure of converter	0.45~0.55MPa	
	Outlet pressure of converter	0.15~0.25MPa	
Transmission box	Shifting gears	Forward-4-Reverse-3	
	Shifting pressure	1.1~1.5MPa	
Tire	Tire specification		17.5—25
	Tire pressure (MPa)	Front wheel	0.333~0.353MPa
		Rear wheel	0.275~0.294MPa
Brake system	Service brake type		Air-over-oil caliper disc brake
	Brake oil pressure (MPa)		0.784

Table 0-4 Hydraulic and steering system

Items	Parameter/contents
Steering angle (°)	38 °
Steering hydraulic system pressure	12Mpa
Working hydraulic system pressure	16MPa
Bucket lifting time (full load)	≤5.3s
Bucket lowering time (unload)	≤2.9s
Bucket unloading time (unload)	≤1.0s
Sum of three operation time	≤9.2s

02 Specification

Table 0-5 Tightening torque of common screws

Bolt strength grade	Yield strength N/mm ²	Bolt nominal diameter mm				
		6	8	10	12	14
		Tightening torque Nm				
8.8	640	9~12	22~30	45~59	78~104	124~165
10.9	900	13~16	30~36	65~78	110~130	180~210
12.9	1080	16~21	38~51	75~100	131~175	209~278
Bolt strength grade	Yield strength N/mm ²	Bolt nominal diameter mm				
		16	18	20	22	24
		Tightening torque Nm				
8.8	640	193~257	264~354	376~502	521~683	651~868
10.9	900	280~330	380~450	540~650	740~880	940~1120
12.9	1080	326~434	448~597	635~847	864~1152	1098~1464
Bolt strength grade	Yield strength N/mm ²	Bolt nominal diameter mm				
		27	30	33	36	39
		Tightening torque Nm				
10.9	900	1400~1650	1700~2000	2473~3298	2800~3350	4111~5481
12.9	1080	1606~2142	2181~2908	2968~3958	3812~5082	4933~6577

Table 0-6 Tightening torque table when the connected part is made of cast iron or aluminum

Bolt grade and torque Bolt specification	8.8		10.9	
	Torque (Nm)		Torque (Nm)	
	Cast iron	Aluminum	Cast iron	Aluminum
M8	20~25	15~20	28~33	15~20
M10	45~50	25~30	55~60	25~30
M12	70~80	50~55	100~105	50~55
M14	110~125	80~90	150~165	80~90
M16	160~180	120~140	220~240	120~140
M18	205~230	165~180	295~320	165~180

Table 0-7 Tightening torque of connector

Connector with copper washer sealing or screw sealing		Connector with O ring	
Connector specification	Tightening torque Nm	Connector specification	Tightening torque Nm
M14, G1/4	34±5	M12×1.5	35±3.5
M18, G3/8	73±10	M14×1.5	45±4.5
M20, G1/2	93±10	M16×1.5	55±5.5
M24	142±20	M18×1.5	70±7.0
M27, G3/4	205±30	M20×1.5	80±8.0
M33, G1	421±49	M22×1.5	110±10
M42	872±98	M27×2.0	170±17
M30	320±40	M33×2.0	310±31

Table 0-8 Tightening torque of 24° cone sealing

Tightening torque of 24 ° cone sealing pipe nuts	
Specification	Tightening torque Nm
M12×1.5	20±5
M14×1.5	30±5
M16×1.5	35±5
M18×1.5	45±5
M20×1.5	50±5
M22×1.5	65±10
M24×1.5	70±10
M26×1.5	85±10
M30×2	115±15
M36×2	145±15
M42×2	210±20

Table 0-9 Tightening torque of hinged bolt

Specification	Tightening torque Nm
M10×1	25~35
M12×1.5	60~75
M14×1.5	80~100
M16×1.5	105~115
M18×1.5	20~130
M22×1.5	140~155
M24×1.5	160~180
M27×2	190~230
M33×2	270~320

Conversion of unit tables

Table 0-10 Length

Unit	CM	M	KM	IN.	FT	YD	Mile
CM	1	0.01	0.00001	0.3937	0.03281	0.01094	0.000006
M	100	1	0.001	39.37	3.2808	1.0936	0.00062
KM	100000	1000	1	39370.7	3280.8	1093.6	0.62137
IN.	2.54	0.0254	0.000025	1	0.08333	0.02777	0.000015
FT	30.48	0.3048	0.000304	12	1	0.3333	0.000189
YD	91.44	0.9144	0.000914	36	3	1	0.000568
Mile	160930	1609.3	1.6093	63360	5280	1760	1
1mm = 0.1cm 1μm = 0.001mm							

Table 0-11 Area

Unit	CM ²	M ²	KM ²	ARE	FT ²	YD ²	IN ²
CM ²	1	0.0001	-	0.000001	0.001076	0.000012	0.155000
M ²	10000	1	0.000001	0.01	10.764	1.1958	-
KM ²	-	1000000	1	10000	1076400	1195800	-
ARE	0.01	100	0.0001	1	1076.4	119.58	-
FT ²	-	0.092903	-	0.000929	1	0.1111	144.000
YD ²	-	0.83613	-	0.008361	9	1	1296.00
IN ²	6.4516	0.000645	-	-	0.006943	0.000771	1
1Ha = 100Ares 1mile ² = 259Ha = 2.59km ²							

Table 0-12 Volume

Unit	CM ³	M ³	DM ³	IN ³	FT ³	YD ³
ML	1	0.000001	0.001	0.061024	0.000035	0.000001
KL	1000000	1	1000	61024	35.315	1.30796
L	1000	0.001	1	61.024	0.035315	0.001308
IN ³	16.387	0.000016	0.01638	1	0.000578	0.000021
FT ³	28316.8	0.028317	28.317	1728	1	0.03704
YD ³	764529.8	0.76453	764.53	46656	27	1
1 gallon (U.S.) = 3,785.41 cm ³ = 231 in ³ = 0.83267 gallon (British)						

Table 0-13 Weight

Unit	G	KG	MT	OZ	Ib. (pound)
G	1	0.001	0.000001	0.03527	0.0022
KG	1000	1	0.001	35.273	2.20459
MT	1000000	1000	1	35273	2204.59
OZ	28.3495	0.02835	0.000028	1	0.0625
Ib. (pound)	453.592	0.45359	0.000454	16	1
1 ton (metric) = 1.1023 tons (U.S.) = 0.9842 tons (British)					

Table 0-14 Pressure

Unit	KIP/CM ²	Bar	Pa= N/m ²	KPa	Lbf/inch ²	Lbf/ft ²
KIP/CM ²	1	0.98067	98066.5	98.0665	14.2233	2048.16
Bar	1.01972	1	100000	0.001	0.00015	0.02086
Pa= N/m ²	0.00001	0.001	1	0.001	0.00015	0.02086
KPa	0.01020	0.01	1000	1	0.14504	20.886
Lbf/inch ²	0.07032	0.0689	6894.76	6.89476	1	144
Lbf/ft ²	0.00047	0.00047	47.88028	0.04788	0.00694	1
1 Kg/cm ² = 735.56 dry measure (mmHg) = 0.96784 atm						

Table 0-15 Unit description

Unit	Abbreviation
Newton metre	N m
Kilopound metre	kpm
Kilopascal	kPa
Megapascal	MPa
Kilowatt	kW
Kilojoule	kj
British thermal unit	Btu
Calorie	ca

03 Tools



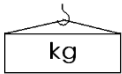



Table 0-16

Common tools	Specification	Quantity	Application
Pneumatic wrench	BQ8, BQ10, BQ16, BQ30, MI-17HE	1 set	Choose the specification according to size of different assembled bolts
sleeve	10, 13, 15, 16, 18, 21, 24, 36, 46	1 set	Choose the specification according to size of different assembled bolts
Soft hammer		1	Hit slightly when assembling some parts with interference.
Solid wrench	5.5×7, 8×10, 10×13, 11×13, 12×14, 13×15, 13×16, 14×16, 16×17, 16×18, 17×19, 18×24, 18×21, 22×24, 24×27, 24×30, 27×32, 30×34, 36×41, 41×46	1 set	Choose the specification according to size of different assembled bolts
Copper bar		1	Hit slightly when assembling some parts with interference.
Feeler gauge		1 set	Adjust the measure of gap positions
Flat tip screw driver		1	Slotted screw
Cross head screw-driver		1	Cross screw
Plier		1	
Clyburn spanner		1	
Crowbar		1	
Specific tools	Specification	Quantity	Application
Frame	Prepare the operation platform if it is not offered.	2	Install or remove working device and axle assembly
Wheelbarrow		1	Install or remove axle assembly
Wooden wedge		1	Fix the machine for repair

04 Marks

In order to emphasize the significance of safety and quality visually, we design the following signs as marks.

Table 0-17

Marks	Items	Notes
	Safety	Be careful for the safety during the operation.
		Be quite careful for the safety if there is pressure inside during the operation.
	Attention	Emphasize the technical requirements to ensure that the operation can meet the requirements of standard during operation.
	Weight	Weight and installation means of parts or device. Carefully select hanging tools and the operation gesture.
	Tightening torque	Pay more attention to the tightening torque of assembly parts.
	Coating	Carefully note the parts need to be coated with grease or adhesion agent.
	Oil, water	Fill a certain amount of water, oil and fuel.
	Draining	Be careful for the parts where water and oil need to be drained and drainage, and judge their volume.

05 Maintenance and Replacement Criteria

051 Visual Inspection or Hand Touching

1. Never further use the parts which are seriously bumped, having fracture and crack, or losing function.
2. Never further use the oil seals, dust ring, O-ring and seal gasket disassembled owing to leakage and because of low reliability and short service life in repeated use.
3. Never further use the bolts, nuts, washers, plug screws, pipe joints if they have serious corrosion, the screw couldn't be tightened, or the screw is damaged, worn out or slipping.
4. Never further use locking steel wire in the connection of bolt after disassembled.
5. Never further use the bearings if they could not be turned smoothly by hand, crack exists on their components or the ball race is seriously worn.
6. Never further use the gears and the teeth of spline with crack, sheet exfoliation, collision or over wearing.
7. Never further use the shell with crack, bearing holes with crack, wear, elliptic or sheet exfoliation, and screw damaged which doesn't work well in tightening operation.
8. Never further use bearing chock, oil seal pedestal with crack, wear, elliptic, collision or sheet exfoliation on the mating surface and spigot.

9. Never further use the pins with serious wear, collision or crack.
10. Judge the oil by visual and touching primarily, it should be replaced if hydraulic oil appears the following situation in the process of use and inspection: present milk white in color, accompany with acid stink, turn yellow or appear turbidity.

052 Measure

If it is hard to identify by ocular estimate or hand touching, check it by measurement.

Table 0- 18

Parts	Check items	Judgment standard		Oversize measures
		Dimension (Tolerance)	Allowable limit	
Bearing	ID tolerance	About 0~-0.02	+0.02	Replace
	OD tolerance	About 0~-0.02	-0.04	
Gear	Wear loss of teeth thickness	About 0~0.10	12 % of the reference circle thickness (usually 1.2~1.4)	Replace
Common parts	OD used in common assembly	Tolerance denoted by T	Recommend: 0.3T less than lower limit	Replace
	ID used in common assembly	Tolerance denoted by T	Recommend: 0.3T more than upper limit	
Multitandem valve	Fitting clearance between valve core and valve hole		>0.02	Replace
Steering device	Fitting g clearance between valve core and valve hole		>0.02	Replace
	Stator and rotor		>0.08	Replace
Monostable valve	Fitting g clearance between valve core and valve hole		>0.02	Replace
Priority valve	Fitting clearance between valve core and valve hole		>0.02	Replace



Service Manual

LG936L

Version:0110



1 Service and Maintenance

CONTENTS

1 Service and Maintenance	1
11 Lubricant, Fuel and Other Liquids	1
111 Lubricant.....	1
112 Fuel	1
113 Coolant.....	2
114 Selection of Oil.....	4
12 Repair	5
121 Notes before Repair	5
122 Periodic Maintenance	8
123 Maintenance and Repair	14

1 Service and Maintenance

Regular maintenance is necessary for high performance of the machine. The viewpoint that the machine doesn't need to be checked regularly if the machine can be used normally is absolutely wrong. Proper examination and maintenance not only can extend the working life of the machine, but also find the malfunctions and deal with them in time, in this way, the maintenance time and cost can be reduced significantly.

11 Lubricant, Fuel and Other Liquids

111 Lubricant

- Lubricant can help to prevent the wear of fitting surface and noise.
- The connectors that are not involved in this manual are only for overhauling and not need to add lubricant. But be sure to fill the lubricant if some parts are difficult to operate for a long time using.
- Clean the spilled lubricant after filling.

112 Fuel

- Fuel pump is precise device, and it will not work normally if the fuel is mixed with water and other impurities.

- Be careful to replace or fill the fuel. Never mix it with impurities.
- Use fuel according to defined brands in the manual.
- Fuel will freeze at low temperature (especially below -15°C), so choose the fuel according to ambient temperature.
- To avoid condensed water from entering into fuel tank, fill the fuel tank fully after work.
- If the engine fail to absorb fuel during starting process or the filter is just replaced, drain the air in the circuit first.

113 Coolant

- To avoid the incrustant from affecting the performance of radiator or blocking the radiator. Be sure to use the antifreeze specified by SDLG all year round. Never use the water as coolant.
- If the engine is overheated, cool the engine and then fill the coolant.
- Coolant should be filled to specified level. Too low level will result in heating of engine and corrosion of cooling system.
- If ambient temperature above 30°C . In the summer day, park the wheel loader in shade because the engine may overheat.
- After operation, run the engine at idle for 5 minutes in order to prolong the service life of engine and stop the engine until the water temperature falls down.
- Antifreeze agent is inflammable and you should keep it away from flame when filling the antifreeze.

- Antifreeze should be replaced every year.
- Never use 100% antifreeze as coolant.
- Choose different antifreeze according to ambient temperature condition, recommended range:
 - 25# is used for ambient temperature $\geq -15^{\circ}\text{C}$
 - 35# is used for ambient temperature $\geq -25^{\circ}\text{C}$
 - 45# is used for ambient temperature $\geq -35^{\circ}\text{C}$

★ ATTENTION

Never mix the different brands of oil. If there is only one brand for selection and it is different from the using oil. Use it after draining all the used oil out.

- **Due to the severe working conditions (high temperature and high pressure) of the wheel loader and dusty in external service environment, the oil is easy to be deteriorated. If so, replace the oil at once.**
- **Fill the required volume of the oil. Adding the oil too much or too little will cause failure.**
- **Clean or replace filter when filling the oil.**
- **Just after operating the engine, all kinds of oil and coolant are hot. Do not open the cap before it is cooled. After cooling, slowly open the cap to release the internal pressure.**

114 Selection of Oil

Please use the oil specified by Shandong Lingong Corp. and chose the oil according to the oil grades as follows:

Table 1-1

Type	Recommended types and application standards	Qty. (L)	Oiling location
Engine oil	Ambient temperature $\geq -15^{\circ}\text{C}$ CD 15W-40 diesel engine oil GB 11122	17	Yuchai Engine
	Ambient temperature $< -15^{\circ}\text{C}$ CD 10W-30 diesel engine oil GB 11122	18	Weichai Engine
	CH-4 15W-40 diesel engine oil GB11122	17.5	Dalian Deutz engine
Hydrodynamic drive oil	6# hydrodynamic drive oil Q/SH303 064	45	Torque converter, transmission box
Gear oil	Heavy duty vehicle gear oil (GL-5) 85W/90 GB13895	13+2 \times 2.5	Main driving of axle and wheel reducers
Hydraulic oil	Ambient temperature $-10^{\circ}\text{C} \sim 40^{\circ}\text{C}$ L-HM46 hydraulic oil GB11118.1 Ambient temperature $-30^{\circ}\text{C} \sim 40^{\circ}\text{C}$ L-HM46 hydraulic oil GB11118.1 Ambient temperature $0^{\circ}\text{C} \sim 50^{\circ}\text{C}$ L-HM68 hydraulic oil GB11118.1	128	Hydraulic oil tank
Fuel	Min. ambient temperature $\geq 4^{\circ}\text{C}$ 0# common diesel GB252 Min. ambient temperature $\geq -5^{\circ}\text{C}$ -10# common diesel GB252 Min. ambient temperature $\geq -14^{\circ}\text{C}$ -20# common diesel GB252 Min. ambient temperature $\geq -29^{\circ}\text{C}$ -35# common diesel GB252	140	Fuel tank
Brake fluid	Motor vehicle brake fluid HZY3 (DOT3) GB12981	4	Brake oil cup
Grease	No.2 or 3 multipurpose lithium-base grease GB7324	—	Pins in the each joint point of the working device
Antifreeze	Ethylene glycol-based engine coolant NB/SH/T0521	34 \pm 2	Radiator

12 Repair

121 Notes before Repair

Park the wheel loader in repair position 1 (Refer to Page 9 in **Safety & Environment**)

- Repair should be performed on solid and flat ground.
- Working device should on ground and bucket should be laid flat.
- Stop the engine and pull out the key.
- All operation handles should be set in the neutral position.
- Press the parking brake button to keep the wheel loader in the state of parking brake.
- Put the blocks under the tires.
- Lock the front and rear frame with frame lock lever.
- Turn off the battery main switch.

Hang warning tag

Attach the warning tag near the starting switch before maintenance to prevent someone starting the engine during maintenance.

Spare parts preparation

Use only parts specified by Shandong Lingong Corp.

Oil and fuel preparation

Use oil and fuel specified in this manual according to ambient temperature.

Use Specified Oil and Fuel

Keep containers of oil and fuel clean and use specified oil and fuel.

Keep the wheel loader clean

Always keep the wheel loader clean. Especially

cleanness of oil filling parts, such as grease cups, oil filling ports, and prevent impurities from infiltrating into those places.

Pay attention to the hot oil and coolant

It is very dangerous to drain hot oil and coolant or remove the filters immediately after the engine just stopped. Make sure the engine is cool. The temperature of the oil drained is appropriately about 20°C to 40°C. If it is lower than this temperature, be sure to warm it up to this temperature before draining it.

Check the oil and filters

After the oil is changed or filters are replaced, check the replaced oil and filters. If large amounts of metallic particles or impurities are found, consult the maintenance personnel.

Fuel coarse filter

Do not remove the fuel coarse filter while fueling.

Oil replacement

Change oil in dust-free places to keep impurities out of the oil.

Welding guide

- Turn off the starting switch of the engine and remove the battery cables.
- Keep the distance between the grounding cable and welding area more than 1m.
- Avoid welding near the seal rings and bearings.
- Never weld any pipe or tube while there is fuel gas or oil in them.

Fire prevention

Clean the parts with unflammable cleaner or light oil. Keep spark or cigarette light away from them.

Sealing elements

When replacing O-ring or sealing gaskets, clean the sealing surfaces first, and make sure the O-ring or sealing gaskets are in the correct assembly position.

Checking the frame

After a long time of stone shoving and transporting operation, check the frame for damage and check whether the connecting nuts and bolts are loose and damaged.

Notes for washing machine

- Wash machine after complete cooling of the engine.

Checking in raining and snowing circumstances

Clean the machine immediately after working in rain and snow. Lubricate and coat anti-rust oil to more parts.

Dusty circumstances

Do the following items when the machine works in dusty circumstances:

- Inspect and clean the air filter frequently to avoid blocking.
- Clean the radiator frequently to avoid blocking.
- Clean and replace the fuel filter frequently.
- Clean the electric components, especially the starting motor and generator, to avoid accumulation of dust affecting dispelling of heat.

Refer to the bring-in **Operation and Maintenance Manual of Diesel Engine** for replacing and maintaining air filter.

122 Periodic Maintenance

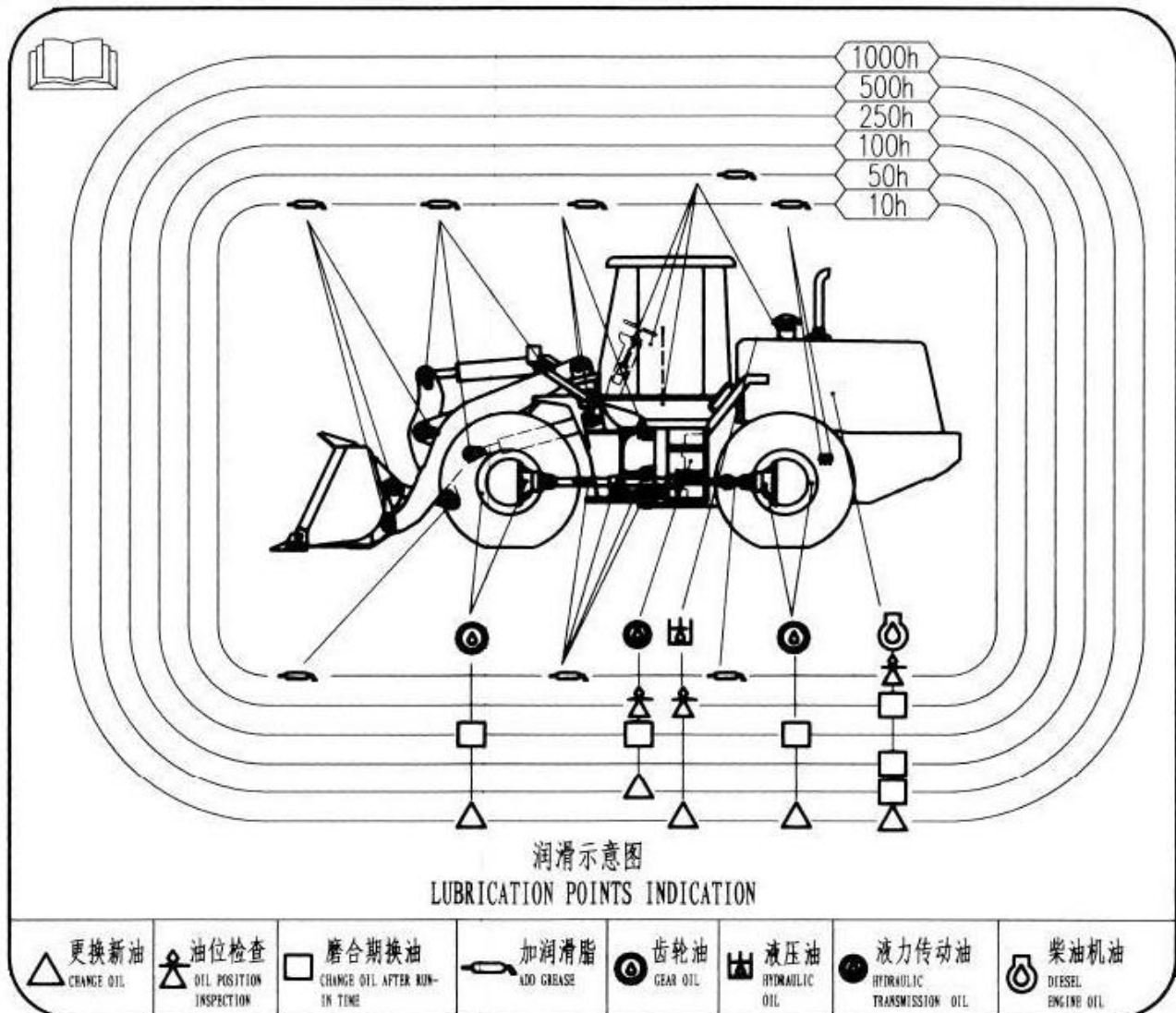

Fig. 1-1

Every 10 Hours (Daily) Maintenance

1. Check the sealing performance of working device, steering system and brake system.
2. Check the flexibility and reliability of the brakes.
3. Check whether the electric circuits are correct and the electric components are normal.
4. Check the oil level in the fuel tank and the coolant level in the water tank.
5. Add grease to the engine fan shaft, jointed point between front and rear frames,

transmission shafts, jointed points of oscillating frame and joint points of working device.

6. Check if there are other abnormalities.
7. Open water drain valve of gasholder to drain water.
8. Refer to **Operation and Maintenance Manual of Diesel Engine** for maintaining the engine.

Every 50 Hours (Weekly) Maintenance

1. Carry out the periodic maintenance of every 10 hours with this maintenance operation at the same time.
2. Check oil level in transmission box, hydraulic oil tank and brake booster pump.
3. Check and tighten all connection bolts of each transmission shaft.
4. Check and tighten all connection bolts of the rim and brake caliper.
5. Check and tighten all connection bolts of bucket teeth.
6. Check and lubricate the accelerator control, parking brake and gearshift control system. In addition, do the extra maintenance in the first 50 hours as follows:
 - Check and clean the air port of the transmission box.
 - Check if there is leakage in the hydraulic system.
 - Check and clean the air vent of the hydraulic tank.
 - Check and clean the oil returning filter of the hydraulic tank.

- Check if there is leakage in the brake system.
- Clean strainer of booster pump oil storage cup, clean the air vent.
- Check brake fluid level and add if necessary.

Every 100 Hours Maintenance

1. Carry out the periodic maintenance of every 10 and 50 hours with this maintenance operation at the same time.
2. Clean the radiator components.
3. Clean fuel tank filler filter.
4. In addition, do the extra maintenance in the first 100 hours as follows:
 - Clean transmission oil sump. (Do this maintenance every 500 working hours thereafter)
 - Check and clean the air vent of transmission box. Replace the filter elements in the oil lines of torque converter-transmission box system. Replace the transmission box oil. (Do this maintenance every 500 working hours thereafter)
 - Replace transmission oil. (Do this maintenance every 500 working hours thereafter)
 - Replace the gear oil in the front and rear axles. (Do this maintenance every 1000 working hours thereafter)

Every 250 Hours (Monthly) Maintenance

1. Carry out the periodic maintenance of every 10, 50 and 100 hours with this maintenance

- operation at the same time.
2. Check the storage battery. Clean surface and terminals of the battery then coat Vaseline on it.
 3. Check whether connecting bolts of frames and working devices are loose and welding seams are cracked.
 4. Check whether the connections of front and rear axles, engine and transmission box and frame are loose.
 5. Check the tire pressure. Inflation pressure of front tires should be (0.33~0.35)MPa, while that of rear tires should be (0.27~0.29)MPa.
 6. In addition, do the extra maintenance in the first 250 hours as follows:
 - Check if there is leakage in the brake system.
 - Clean strainer of booster pump oil storage cup, clean the air vent.
 - Check Brake fluid level and add if insufficient. Replace it if necessary.

Every 500 Hours (Seasonally) Maintenance

1. Carry out the periodic maintenance of every 10, 50, 100 and 250 hours with this maintenance operation at the same time.
2. Check and adjust the brake clearance of parking brake system.
3. Check the wear condition of brake discs and friction discs. Replace them if necessary.
4. Clean the silencer of the brake electromagnetic valve.
5. Clean the oil sump of transmission box.
6. Check and clean the air vent of transmission

box.

7. Replace the filter elements in the oil lines of torque converter-transmission box system.
8. Replace the transmission box oil.
9. In addition, do the extra maintenance in the first 500 hours as follows:
 - Check if there is leakage in the hydraulic system. (Do this maintenance every 1000 working hours thereafter)
 - Check and clean the air vent of hydraulic tank. (Do this maintenance every 1000 working hours thereafter)
 - Replace the oil-return filter element of hydraulic tank and pilot filter element (if installed). (Do this maintenance every 1000 working hours thereafter)
 - Check the quantity and cleanness of hydraulic oil. Filter the oil if possible. Add them if insufficient and replace them if necessary.
 - Check if there is leakage in the brake system. (Do this maintenance every 1000 working hours thereafter)
 - Clean strainer of booster pump oil storage cup, clean the air vent. (Do this maintenance every 1000 working hours thereafter)
 - Replace brake fluid. (Do this maintenance every 1000 working hours thereafter)

Every 1000 Hours (Biannually) Maintenance

1. Carry out the periodic maintenance of every 10, 50, 250 and 500 hours with this maintenance operation at the same time.

2. Replace the gear oil in the front and rear axles. Do this replacement at least once a year.
3. Check the clearance and wear condition of the pins and the bushes in every articulated point.
4. Check and clean strainer of booster pump oil storage cup, clean the air vent.
5. Replace brake fluid.
6. Check if there is leakage in the hydraulic system.
7. Check and clean the air vent of hydraulic tank. Clean hydraulic tank.
8. Replace the oil-return filter element of hydraulic tank and pilot filter element (if installed).
9. Replace hydraulic oil.

Every 2000 Hours (Yearly) Maintenance

1. Carry out the periodic maintenance of every 10, 50, 100, 250, 500 and 1000 hours with this maintenance operation at the same time.
2. Replace antifreeze every 2000 working hours or once a year, whichever comes first.
3. Check performance of the torque converter and transmission box, differentials of front and rear axles and the wheel side reducers.
4. Check the sealing performance of multitandem valve and hydraulic tank by measuring the natural sedimentation volume of the cylinder fuel oil, and then check the system pressure.
5. Check the welding seams of rim and other stress areas and adjust the deformation.
6. The maintenance principles listed above are the basic requirements. The maintenance time should be determined by the closer one

between two the maintenance schedules. If the working condition is very severe, please shorten the maintenance cycle and increase the maintenance times according to the real conditions.

123 Maintenance and Repair

Brake check

Observe whether its appearance is normal, such as oil leakage.

Draining drive axle oil

If you cannot make sure whether the fuel is cooled, please wear protective cloth in case of burning.

1. Make sure the draining plug is at lowest position and you can rotate the wheel if necessary. (Refer to Fig. 1-2)

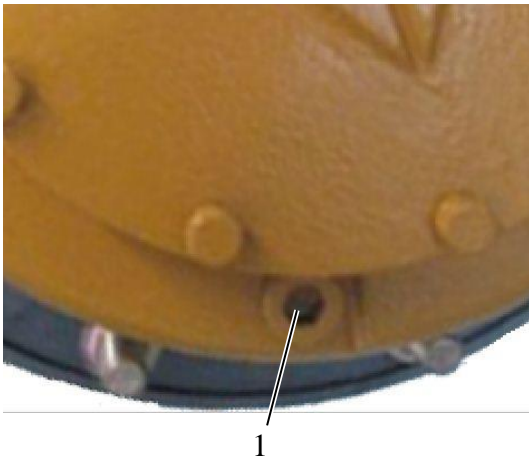

Fig. 1-2
1 Wheel side oil drain plug (keep it at the lowest place while draining)



Fig. 1-3
1 Oil drain plug of axle housing

2. Place the container under the main reducer and hub to drain the oil. Check and clean the plug and O-ring, replace them if necessary. (Refer to Fig. 1-3)

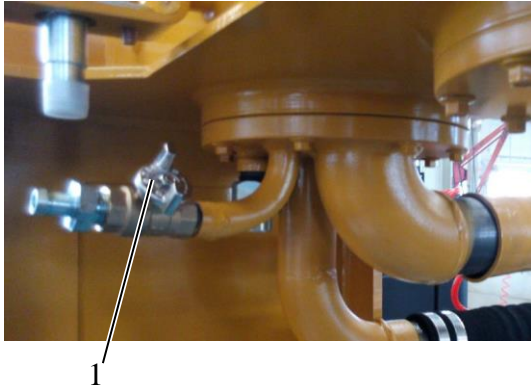

Fig. 1-4
1 Oil drain port of hydraulic tank

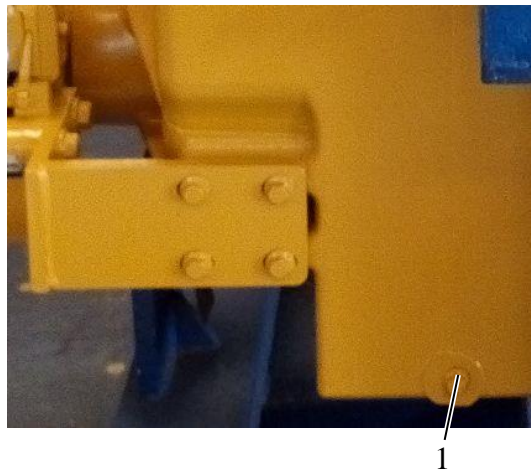

Fig. 1-5
1 Oil drain port of transmission box

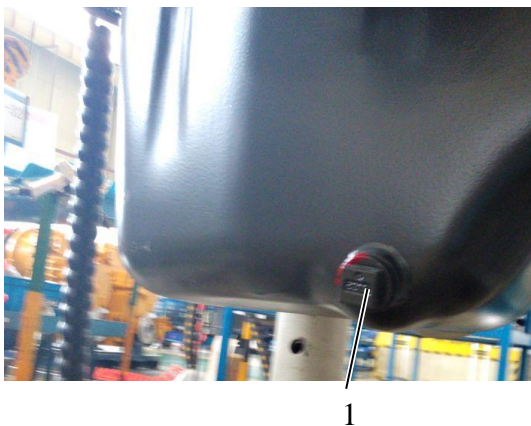

Fig. 1-6
1 Oil draining plug

Draining of oil in the hydraulic tank

1. After the engine is cooled, wear protective cloth.
2. Connect the hose to hydraulic oil draining port and the other end should be diverted to empty container (Place an empty container aside and the total volume of the tank is 128L, refer to Fig.1-4)
3. Open the valve and drain oil to the empty container.
4. Disconnection the hose.

Draining of hydrodynamic drive oil in transmission box

Do the maintenance after the machine is cooled.
Open the draining plug and drain the oil to empty container. (Refer to Fig. 1-5)

Engine oil draining

Do the maintenance after the machine is cooled.
Place the empty container under the engine and open the oil draining plug. (Refer to Fig. 1-6)



1

Fig. 1-7
1 Primary fuel filter



1

Fig. 1-8
1 Fine fuel filter



1

Fig. 1-9
1 Engine oil filter

Replacement of fuel filter

1. Remove three filters with filter wrench (Refer to Fig. 1-7, Fig. 1-8)

2. Coat the seals of new filters with engine oil. And tighten them according to the guide in the manual.

3. Deflate the fuel system after replacing the filters.

Replacement of engine oil filter

Maintenance it after it is cooled.

1. Replace the engine oil filter.

2. Smear new engine oil on the new filter. (Refer to Fig. 1-9), tighten it according to the requirements described in the manual.



1

Fig. 1-10
1 Air filter

Replacement of engine air filter

1. Replace the main filter at least once a year, or replace it when the filter is blocked and alarm. During replacing, clean the filter cover hood, because it is used to contain the particle that is not filtered by filter.
2. Check and ensure that all the hoses and connectors from air filter to engine manifold have no leakage problem. Check and tighten the clamps.
3. Replace the safety filter at least every other year or when the main filter is replaced 3 times. (Refer to Fig. 1-10)



1

Fig. 1-11
1 Transmission oil filter

Replacement of transmission oil filter

Overhaul the machine after it is cooled.

1. Drain the oil out and then remove the filter. (Refer to Fig. 1-11)
2. Install new filter and tighten it according to the instructions described in the manual.

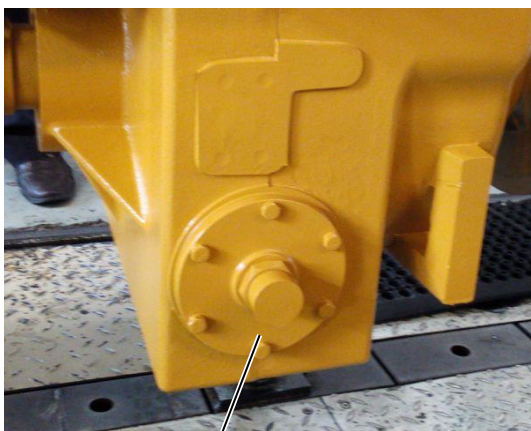

1

Fig. 1-12
1 Oil drain plug

Clean the oil absorption filter screen of transmission box

1. Remove the cover and clean the internal parts. Check and ensure the parts are not damaged.
2. Install a new gasket between cover hood and transmission box
3. Install the absorption screen again. (Refer to Fig. 1-12)



Fig. 1-13
1 Belt

Transmission belt checking

Check tension of belt and whether the tensioning rod is worn. (Refer to Fig. 1-13)



Fig. 1-14
1 Engine oil filling port

Engine oil filling

Fill the engine oil of specified volume (Refer to Fig. 1-14)

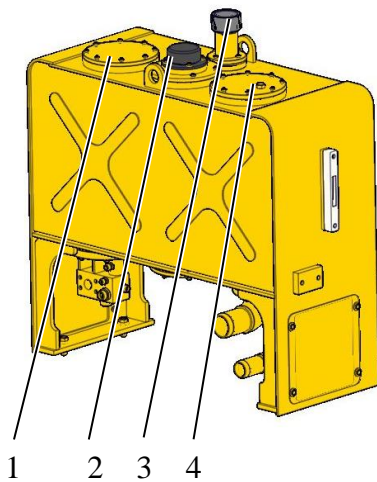

Fig. 1-15
1 Oil absorption flange
2 Hydraulic oil filling port
3 Ventilation filter
4 Upper oil absorption flange

Replacement of vent filter of hydraulic tank

Replace the filter. (Refer to Fig. 1-15)

Replacement of oil-return filter of hydraulic tank

1. Remove the cover and hood. (Refer to Fig. 1-15)
2. Remove the filter.
3. Install new filter.
4. Check the sealing ring in cover hood when installing it.

Hydraulic oil filling

1. Fill the hydraulic oil to the specified level. (Refer to Fig. 1-15)
2. Control the oil level by using round oil pointer.

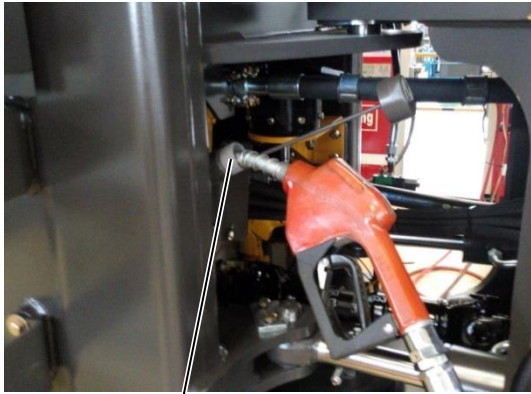

1

Fig. 1-16

1 Filling port of transmission oil

Transmission oil filling

Fill transmission oil until oil overflows but no pressure is formed.



1

Fig. 1-17

1 Filling port of axle housing

Drive axle gear oil filling

1. Keep the wheel side draining plug in tire horizontal shaft position.
2. Fill specified gear oil via the oil draining ports on the two wheel sides of drive axle and the filling port in the middle of axle housing.
3. Fill the oil until the level gets the edge of oil level plug.

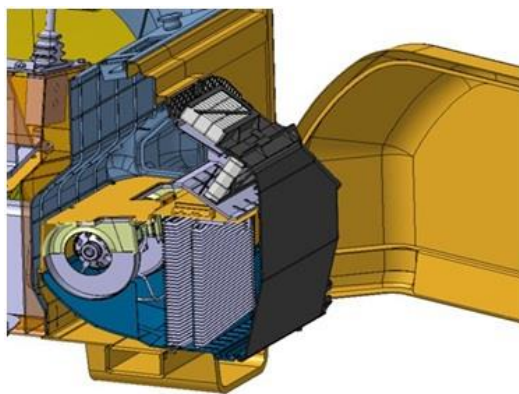

Fig. 1-18

Replacement of internal circulation filter and external circulation filter in the cab

1. Open the side cover. (Refer to Fig. 1-18)
2. Rotate the fixing parts aside and then remove external circulation filter and put it aside.
3. Rotate the fixing parts aside, and then remove the lower shell. Remove the internal circulation filter and put it aside.
4. Install new filters, shell and new prefilter and then close the cover.

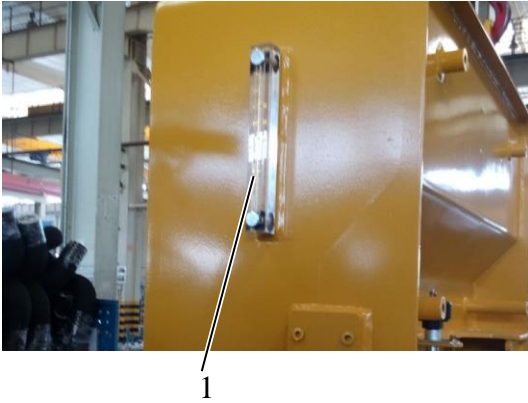

Fig. 1-20
1 Bar-type oil pointer

Hydraulic oil level checking

Keep the boom at the lowest position. Observe the oil level via the bar-type oil pointer.

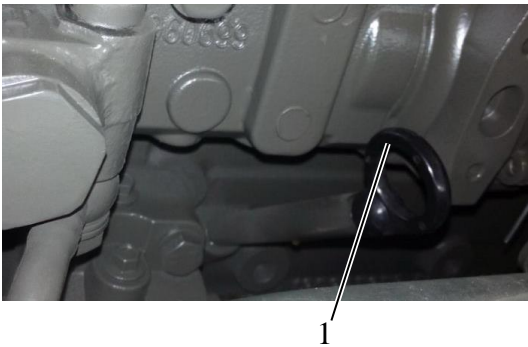

Fig. 1-21
1 Engine oil dipstick

Engine oil level checking

Oil level should be between “max” mark and “min” mark on the oil dipstick.



Fig. 1-22
1 Water tank cap

Coolant level checking

Open water tank cap to check coolant level, oil level should be in specified range.

If you fill the coolant, do not open the cover when the coolant is hot. Wait until it is cooled.



Fig. 1-23

Checking of battery, cable and connectors

Touch the liquid of battery will cause severe chemical burning.

Wear protective gloves, goggles and clothes when maintaining the battery.

1. Open the battery cover. Open one hood each time.
2. Check and clean the connectors of cable and terminals and bolts of battery, and coat the external surface with grease as anticorrosion, such as Vaseline. (Refer to Fig. 1-23)
3. Check the liquid level, and the green color means normal.



Fig. 1-24

Radiator cleaning

1. Open the engine hood.
2. Clean the fins of radiator with compressed air along the rotating direction. (Refer to Fig. 1-24)

Install the grid shield device.

If it is not dealt properly, the fins of radiator may be damaged.



Service Manual

LG936L

Version:0210



2 Engine

CONTENTS

2	Engine System	2-1
21	General.....	2-1
211	Engine Description	2-1
212	Engine Identification	2-1
213	Product Model Composition and Significance.....	2-2
214	Cylinder Number	2-2
215	Engine Working Principle	2-2
216	Engine Block	2-3
217	Cylinder Head.....	2-4
218	Overall Engine Performance Parameters	2-5
22	Lubrication System.....	2-6
23	Fuel Supply System.....	2-7
231	Fuel Circuit	2-8
232	Injection Circuit.....	2-8
233	Fuel Return	2-8
24	Cooling System.....	2-9
241	Function of Cooling System.....	2-10
242	Thermostat	2-10
25	Intake and Exhaust System.....	2-11
251	Intake System	2-11
252	Exhaust System.....	2-11
253	Turbocharger	2-12
26	Disassembly and Assembly of Engine	2-13
261	Disassembly of Engine	2-13
262	Assembly of Engine	2-25
27	Disassembly and Assembly of Fuel Tank	2-37
271	Disassembly of Fuel Tank	2-37
272	Assembly of Fuel Tank	2-39
28	Disassembly and Assembly of Radiator.....	2-41
281	Disassembly of Radiator.....	2-41
282	Assembly of Radiator	2-44

29 Diagnosis and Troubleshooting of Engine System Common Faults.....	2-47
291 Engine Fails to Start.....	2-47
292 Engine Power is Not Sufficient	2-47
293 Exhaust Exceptions (Black Smoke, White Smoke, Blue Smoke).....	2-48
294 Engine Oil Pressure is Too High or Too Low	2-49
295 Large Consumption of Engine Oil	2-50
296 High Coolant Temperature	2-50

2 Engine System

21 General

211 Engine Description

This manual takes WEICHAI DEUTZ WP6G125E22 engine as example, for LG936L equipped with other engines can use it as a reference.

Features of DEUTZ products are: high torque, easy to cold start and full load running, slender engine design, low weight, easy to be assembled on the vehicle, low fuel consumption, low emission, low noise and low vibration, etc. The engine also featured with compact overall design and convenient maintenance.



Fig. 2-1 Engine

212 Engine Identification

The serial number is printed on nameplate, which is located on the engine cylinder block.

You must indicate the engine type and serial number when ordering spare parts.

213 Product Model Composition and Significance

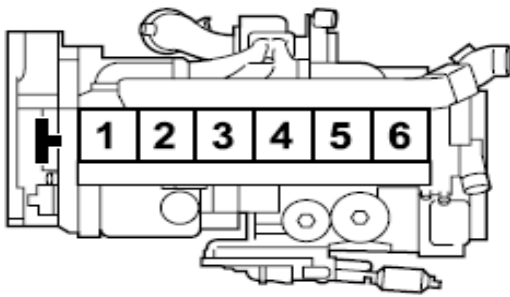
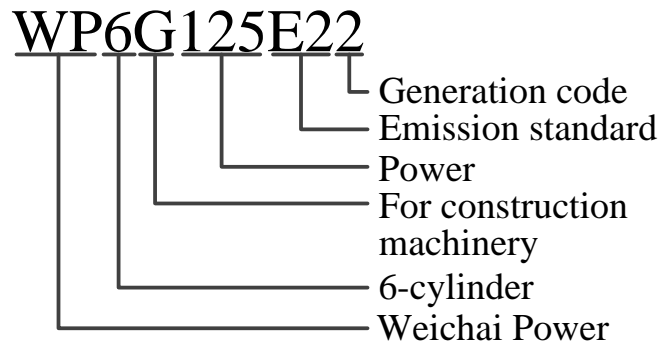

Fig. 2-2 Cylinder number

214 Cylinder Number

The cylinders are numbered sequentially. Ignition sequence: 1-5-3-6-2-4. From the point of view of flywheel, the rotating direction of engine is anti-clockwise.

215 Engine Working Principle

The diesel engine is designed with four strokes, every working cycle consists four processes, i.e. intake, compression, power and exhaust. Specifically speaking, during air intake, engine inhales fresh air continuously until the piston approaches the bottom dead center (BDC), marking the end of intake. Then, the compression stroke begins as the piston starts moving upwards, during which the fresh air is compressed by the piston and its temperature rises. When the piston approaches TDC, the diesel is atomized and then injected into combustion chamber via injector, where it is mixed with high temperature gas (i.e. gas mixture is formed) and combusts automatically

and quickly. When the pressure generated from self-combustion forces the piston to move downwards, the power stroke begins, which will be ended as the piston gets close to BDC. Following this, the exhaust stroke starts as the piston moves upwards by the force of inertia, and when it approaches TDC, all remaining waste gas resulted from mixture combustion is discharged, marking the end of exhaust stroke.

That's the whole working circle of the diesel engine.

216 Engine Block

1. Engine assembly

Engine assembly mainly consists of engine block, cylinder sleeve, gear room, rear oil sealing cover, flywheel housing and oil sump tank, etc.

The engine adopts high gantry type block:

- Crankcase sealing surface is lower than crankshaft axis.
- Enhanced the stiffness of the bottom half engine block.

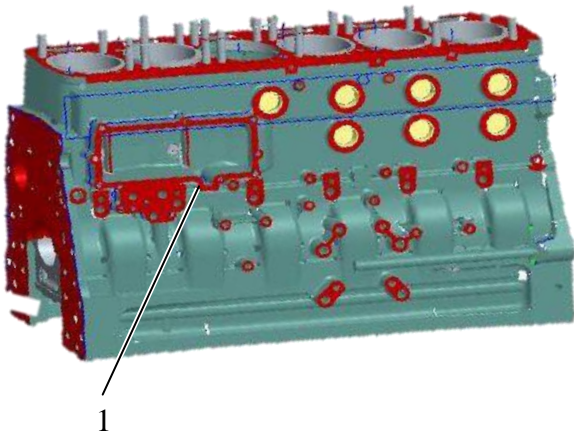

1
Fig. 2-3
1 Engine block assembly

Wet-type cylinder sleeve

- The cylinder sleeve outside surface contacts with the coolant directly;
- Excellent cooling performance, can avoid cavitation effectively;

Advantages: Make the layout of the whole

machine more reasonable, leakage is avoided, and fuel can be preheated in advance. The convenience of service and maintenance has been adequately considered in the design process

217 Cylinder Head

Cylinder head is casted from gray cast iron and applied unitary structure.

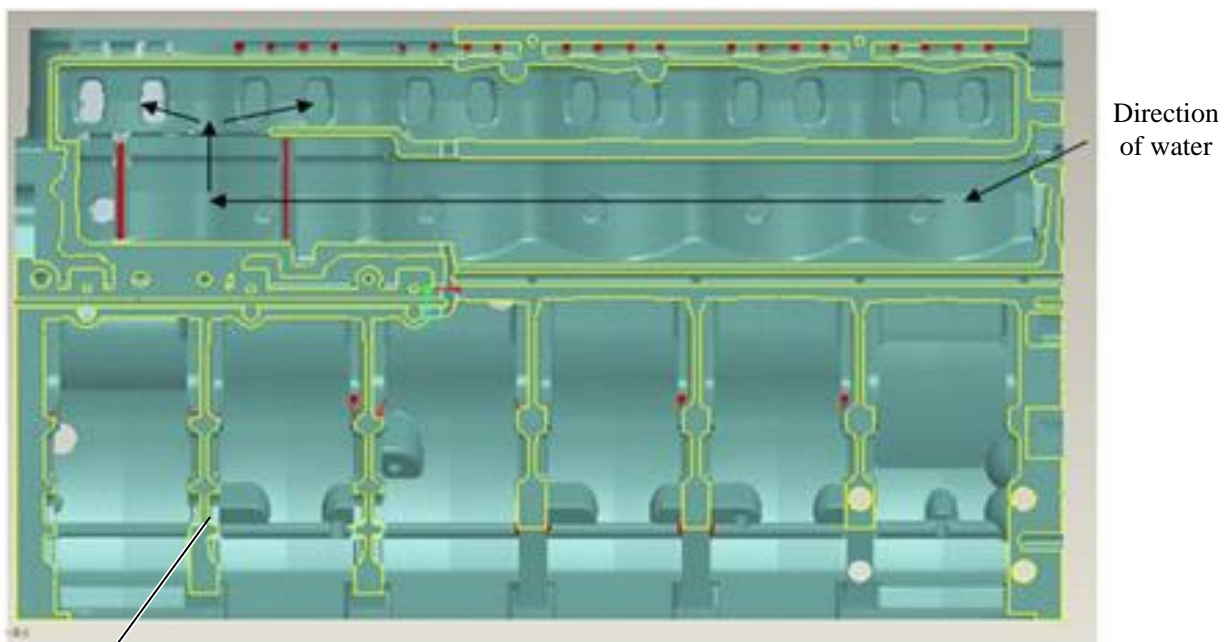

1

Fig 2-4
1 Cylinder Head

Cylinder head applies high water inflow, which can improve the cooling speed of the piston and cylinder sleeve. The temperature of the water-resisting ring in top of cylinder sleeve reduces from 300°C to 200°C.

218 Overall Engine Performance Parameters

Table 1 Engine parameters

Items	Parameters	Items	Parameters
Model	WP6G125E22	Number of cylinders	6
Type	Supercharge	Cylinder diameter/stroke (mm)	105/130
Rated power (kw)	92	Minimum specific fuel consumption (g/kwh)	225
Rated speed (r/min)	2200	Maximum torque (Nm)	500
Output volume (ml)	6750	Emission standard	Chinastage II

22 Lubrication System

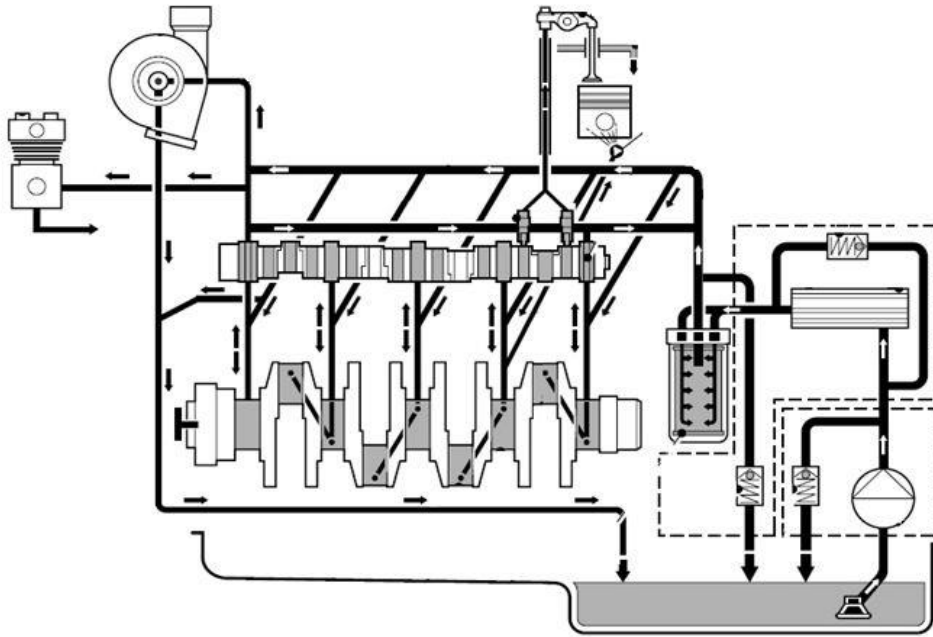

Fig. 2-5 Route diagram of force-feed lubrication

The oil pump absorbs engine oil from the oil sump through oil pump, and then the oil flows throughout the engine via the oil pipes. For components which have relative motion, wherein oil film will be formed, the abrasion between parts can be significantly reduced and service life of engine is lengthened. The engine is also equipped with piston cooling nozzle to reduce working temperature of the piston.

23 Fuel Supply System

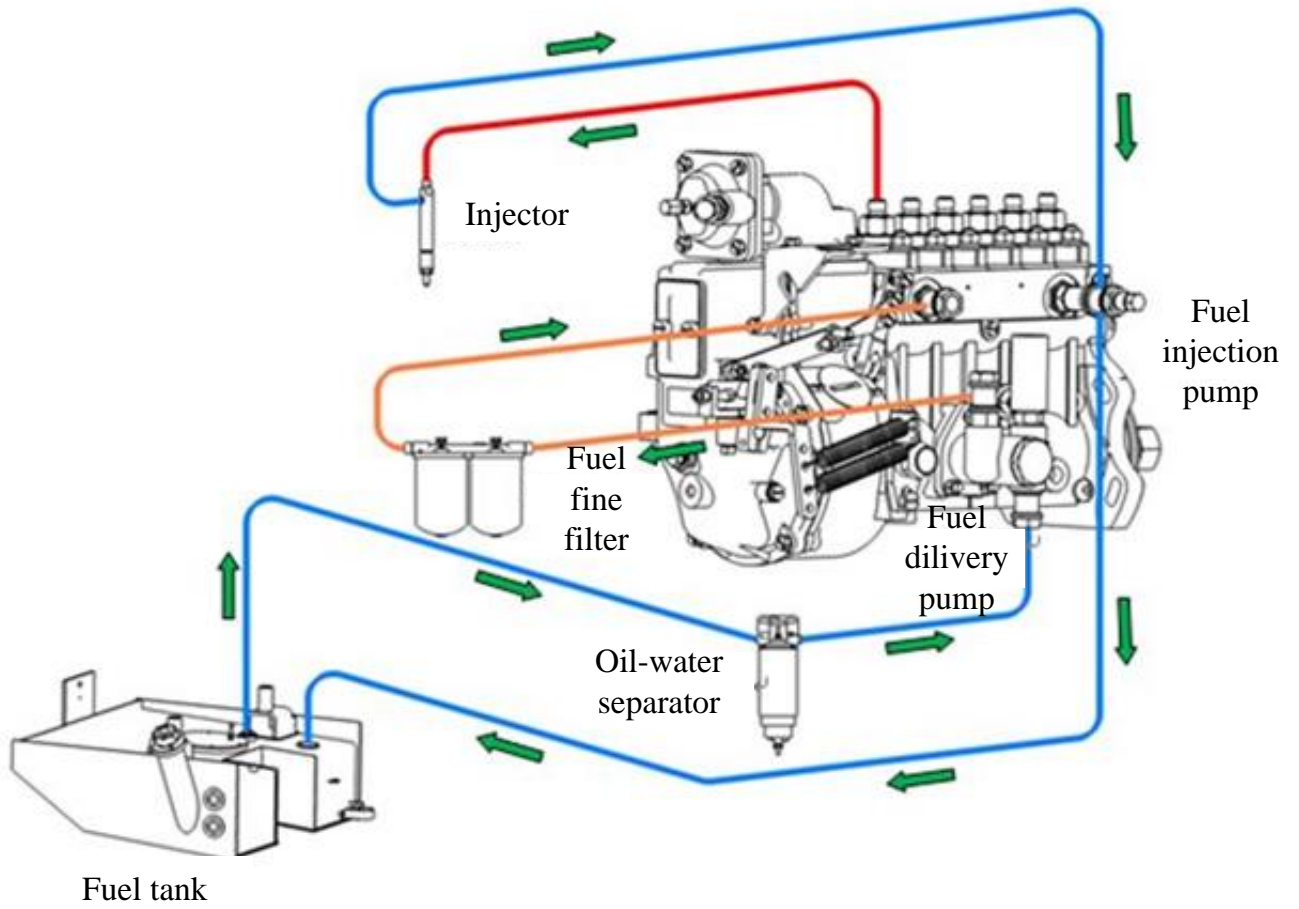

Fig. 2-6 Fuel system

Fuel supply system includes: fuel pump, governor, oil transfer pump, fuel filler, injector, and injection pump, etc.

231 Fuel Circuit

Firstly, the fuel pump pumps fuel from fuel tank to fuel injection pump through filter and inlet pipe of the injection pipe. Some of the fuel enters into injection circuit, namely, injector – combustion chamber, most of the fuel goes into the oil return chamber in cylinder block via injection pump to form fuel return circuit, stabilized pressure in low pressure circuit is vitally important for engine power output. If the situation of under-capacity of engine occurs, check the fuel pressure first.

The fuel control valve is used to control oil pressure in fuel return circuit. The major cause to oil leak (cavitation) of injector is insufficient pressure of low pressure circuit, so ensure the cleanness of fuel filter and replace it if necessary.

232 Injection Circuit

The fuel in injection pump enters into the injector via a short oil pipe, injector begins to work to inject fuel into the combustion chamber.

233 Fuel Return

Due to the oil supply rate of fuel pump is more than ten times larger than the capacity of injector, a lot of excess fuel will return back to fuel tank via the pressure control valve, leaked fuel from injector during working gap returns to fuel tank too, which has the effect of cooling the combustion. Moreover, air in oil line can be bled out under the action of large amount of return fuel, self-bleeding function is available.

24 Cooling System

The coolant pump intakes low temperature water from an attached radiator through the thermostat, the cooling water flows through engine oil radiator, then enters into the water jacket in the cylinder block to cool the cylinder liner, then the water enters into water jacket of cylinder head through water channel, finally returns to the radiator.

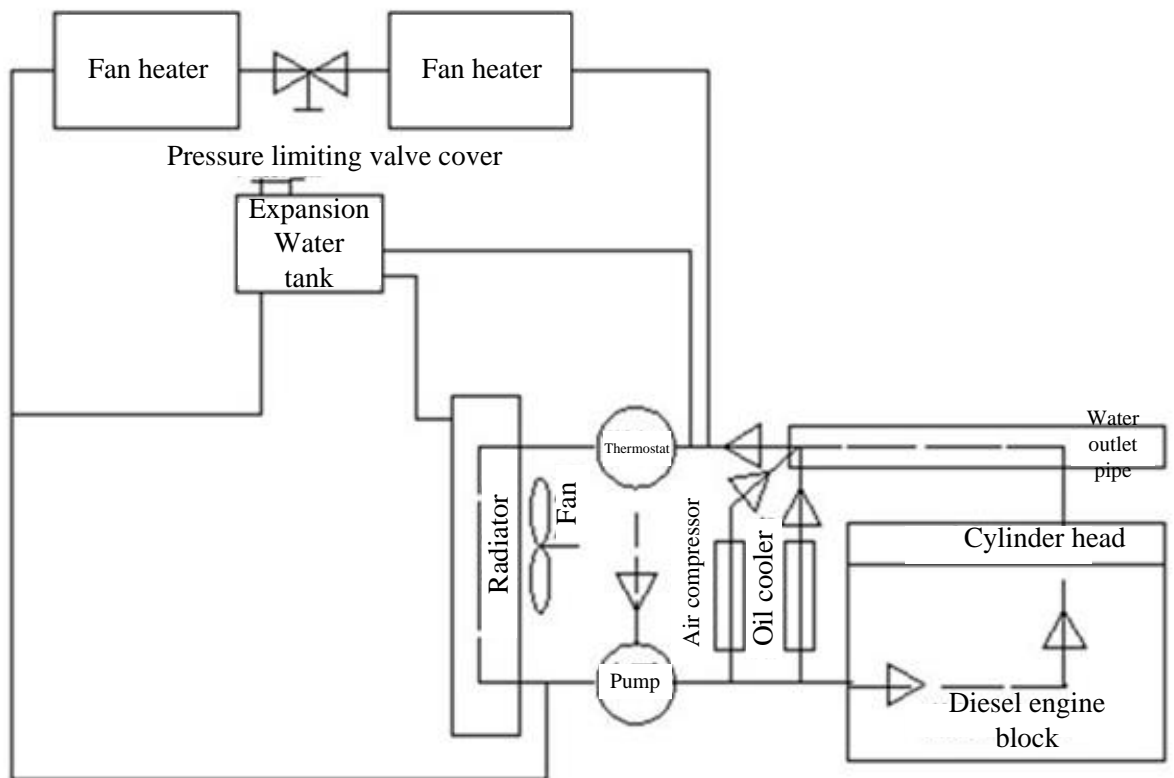

Fig. 2-7 Cooling system

241 Function of Cooling System

When the engine is running, a large amount of heat is generated by fuel combustion and friction between moving parts, some parts are subjected to strong heat, especially the parts exposed to burning gas directly, without proper cooling, the normal working of engine cannot be guaranteed. The purpose of cooling system is to keep the engine working under proper temperature.

WP6G125E22 is water cooling engine. Water is the direct heat-transfer medium, then the heat is passed down to air. That is, using a small amount of water in engine water jacket to absorb excess heat, in a continuously circulating way, and then dissipate the heat in the radiator. Because of the temperature difference between inlet and outlet of water jacket is small, so the bottom of cylinder wouldn't be undercooled, besides, the cooling intensity can be easily adjusted to keep the engine working under normal temperature. In winter, hot water can be used to preheat the engine.

242 Thermostat

The function of thermostat is to change the circulating intensity (route and flow) along with engine load and water temperature. Meanwhile, it is also used to shorten the engine warm-up time, to reduce fuel consumption and abrasion between parts.

25 Intake and Exhaust System

251 Intake System

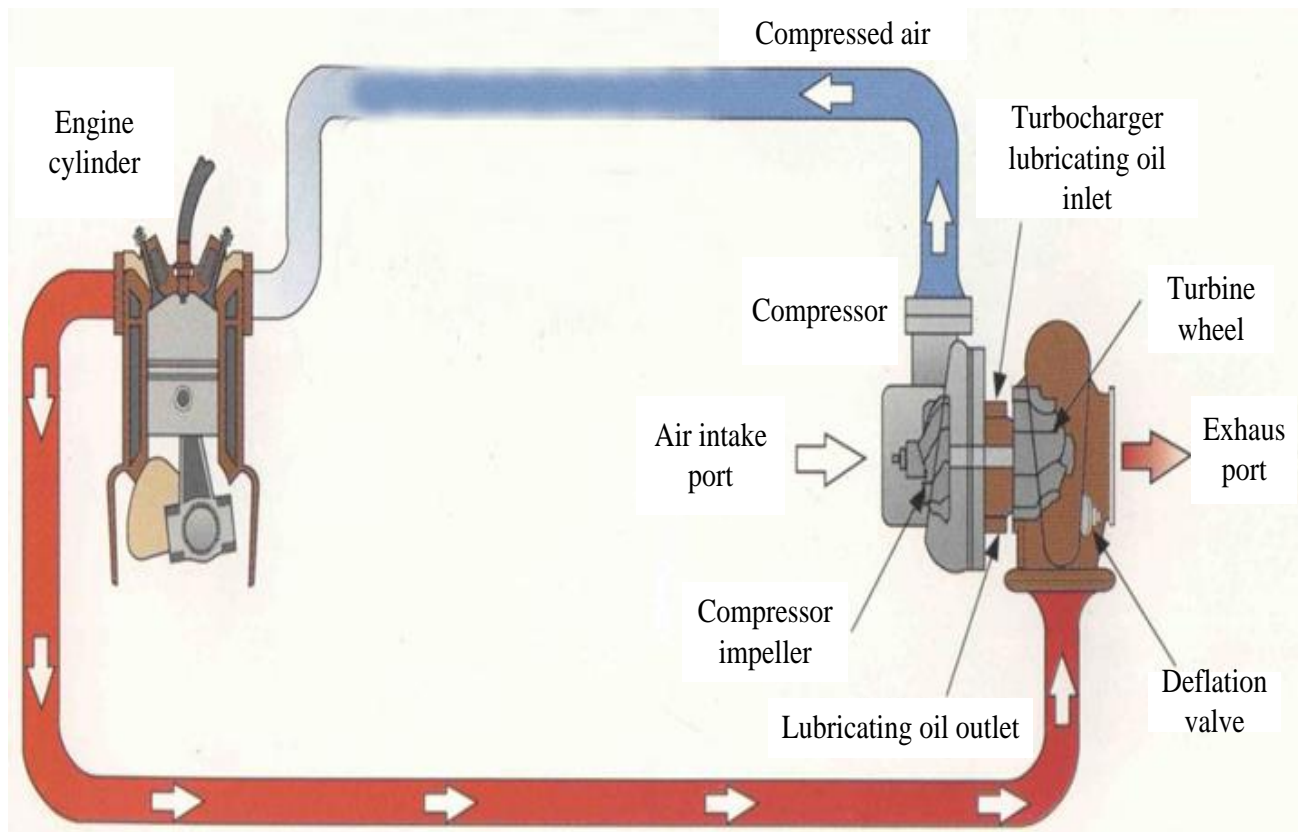

Fig. 2-8 Intake and exhaust system

Air is absorbed in through air filter, and then flows into turbocharger. After the air outflows from turbocharger, the condensed air finally arrives at the cylinder through the inlet manifold and intake valve, mixes up with the fuel and burns.

252 Exhaust System

Firstly, the exhaust gas flows into the silencer through turbocharger, discharge into the environment through exhaust pipes at last.

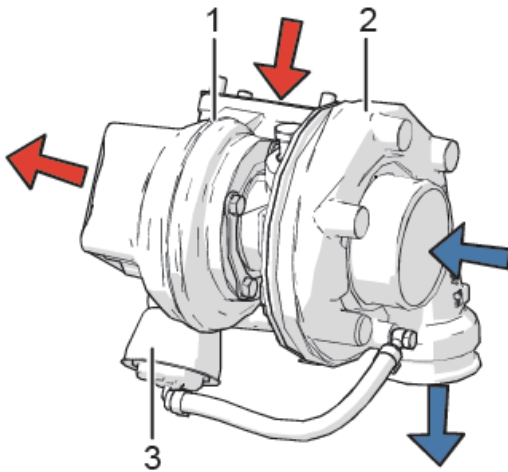

Fig. 2-9 Turbocharger

253 Turbocharger

The turbocharger is driven by exhaust gas, the exhaust gas flows through the turbine casing on its way to DPF module.

Exhaust airflow drives the turbine rotor in the turbine casing. The compressor rotor and turbine rotor locate on the same shaft, the former located in the housing that connected between air filter and intake manifold.

When compressor rotor rotates, it will suck air from the air filter. The turbocharger is equipped with an exhaust by-pass valve. The exhaust by-pass valve is controlled by pressurized air, to allow a small amount of exhaust gas bypass turbine rotor under high engine speed (highpressurized air pressure).

26 Disassembly and Assembly of Engine

261 Disassembly of Engine

These following steps could be referred to disassemble the engine from the machine when the engine needs to be replaced, examined or repaired.

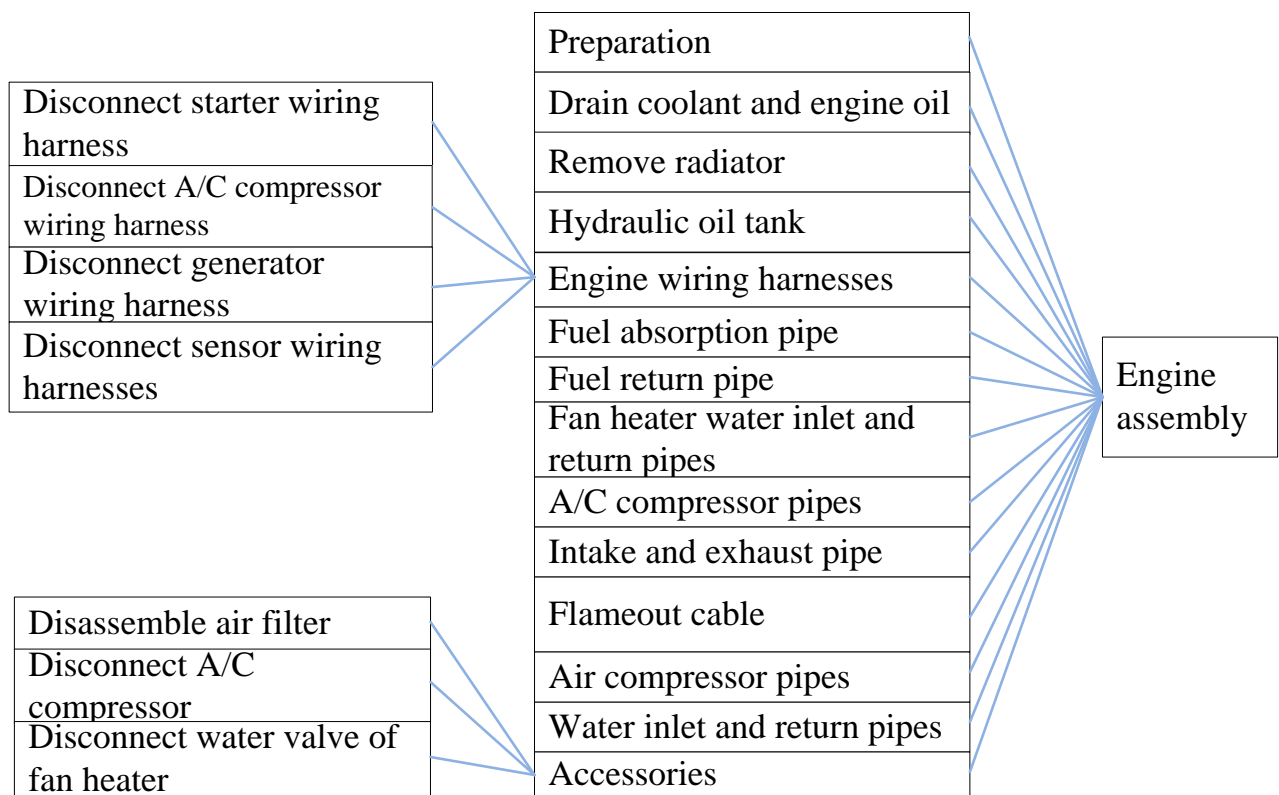



Fig. 2-10
1 Wood block 2 Tire

1. Start the machine and drive it to the maintenance position. Keep the bucket flat on ground. Press the parking brake switch on the operation box. Turn the key of the electrical lock to shut down the engine, turn off the electrical power of the whole machine 5min later. Wedge the front and rear tires with wood blocks.

★ **Do the following operations after the loader cools down. During the processes of disassembly, all the pipeline joints should be wrapped up to avoid the debris entering into the pipeline.**

2. Open the water drain valve of radiator. Drain the cooling water out and contain them with clean vessel.

 Coolant

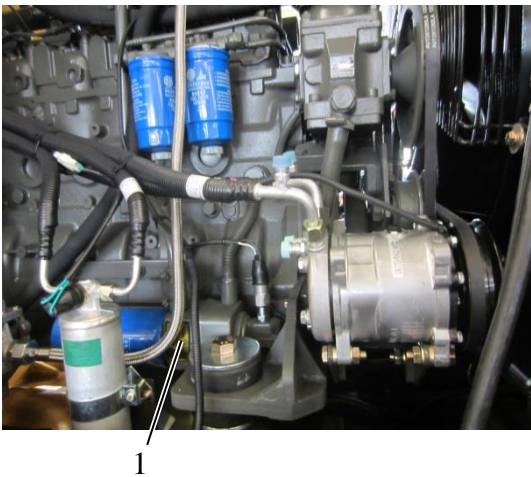

Fig. 2-11
1 Water drain valve

3. Open the oil drain plug on engine sump and drain the engine oil, contain them with a clean vessel.

 Engine oil



Fig. 2-12
1 Oil drain plug



1
Fig. 2-13
1 Radiator



1
Fig. 2-14
1 Hydraulic oil tank



1 2
Fig. 2-15
1 Starter power wiring harness
2 Engine assembly

4. Remove the engine hood.

Refer to **Disassembly of Radiator** in this chapter.

5. Remove the hydraulic oil tank.

Refer to **Disassembly of Hydraulic Oil Tank** in chapter 9.

6. Disconnect wiring harness of engine.

★ **Don't damage the wiring harness connector.**

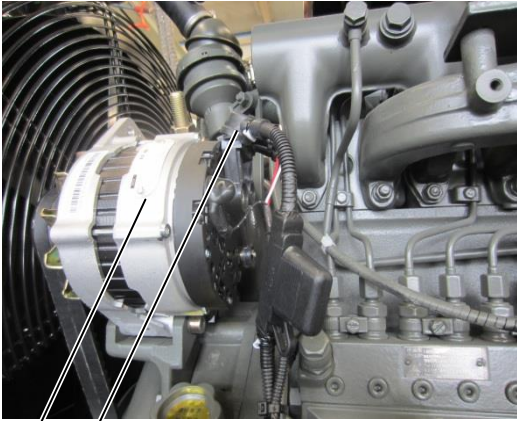

1 2

Fig. 2-16

1 Electric generator

2 Electric generator wiring harness

7. Remove the electric generator wiring harness.



1 2

Fig. 2-17

1 Wiring harness

2 A/C compressor

8. Disconnect the wiring harness of A/C compressor.



1 2

Fig. 2-18

1 Water temperature sensor

2 Engine oil pressure sensor

9. Disconnect the sensor wiring harnesses.

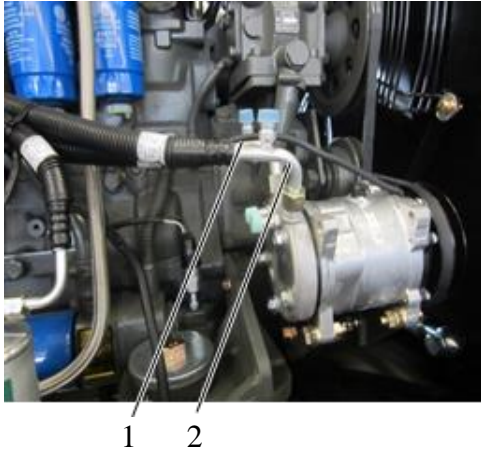

Fig. 2-19

- 1 High pressure pipe of compressor
- 2 Low pressure pipe of compressor

- 10. Disconnect the high pressure pipe and low pressure pipe of compressor.

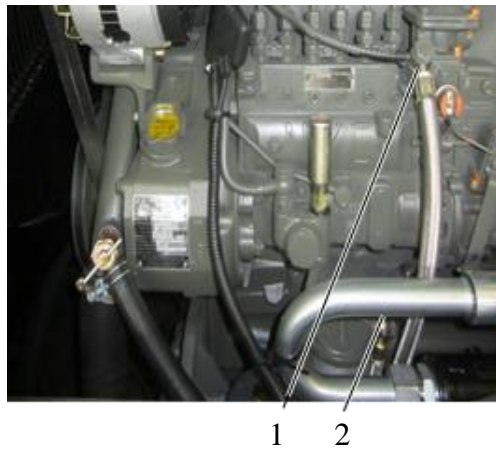

Fig. 2-20

- 1 Fuel return pipe connector
- 2 Fuel absorption connector

- 11. Disconnect engine fuel absorption pipe and fuel return pipe.



Oil may drop, protect the oil port to avoid contamination.

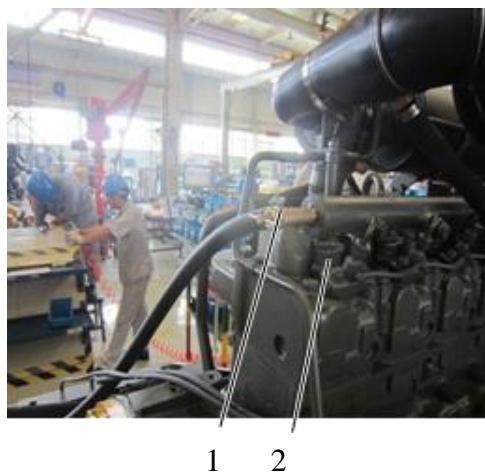

Fig. 2-21

- 1 Water inlet of warm air blower
- 2 Engine

- 12. Cut off the water inlet pipe of fan heater.



Protect the connector and avoid the contamination.



1

Fig. 2-22

1 Return pipe of warm air blower

13. Disconnect water return pipe of fan heater.



Protect the connector and avoid the contamination.



1 2

Fig. 2-23

1 Intake hose

2 Clamp

14. Disconnect the connection between intake hose and air filter.

Refer to **Disassembly of engine accessories** in this chapter.



1 2 3

Fig. 2-24

1 Silencer 2 Nut 3 Turbocharger

15. Remove the nut, cut off the connection between silencer and turbocharger.



Take precautions to avoid foreign matter entering into supercharger.

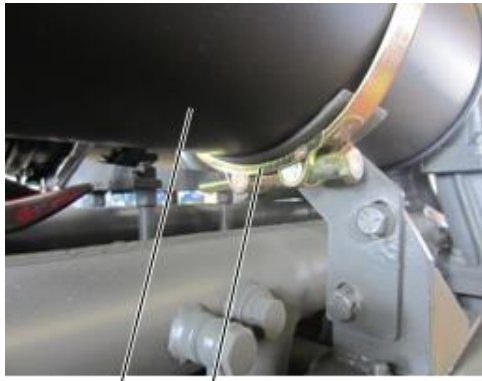

1 2

Fig. 2-25

1 Silencer

2 Clamp

16. Disconnect the clamp of silencer.



1 2

Fig. 2-26

1 Fixing clamp

2 Air filter

17. Disconnect the fixing clamp of air filter.



1 2 3

Fig. 2-27

1 Clamp

2 Inlet of radiator

3 Radiator

18. Remove the clamps and disconnect the connection between water inlet pipe of radiator and engine.



Fig. 2-28
1 Return pipe of engine

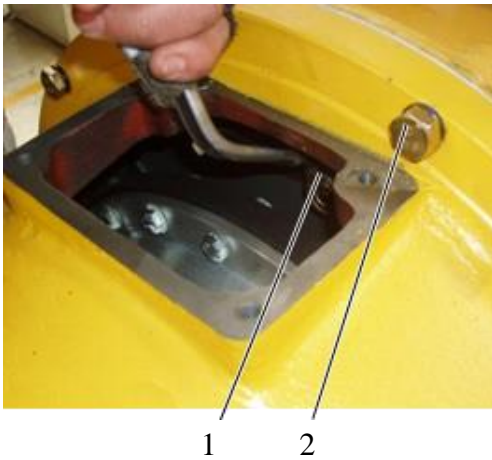

Fig. 2-29
1 Connecting nut of torque converter
2 Connecting bolt of transmission box

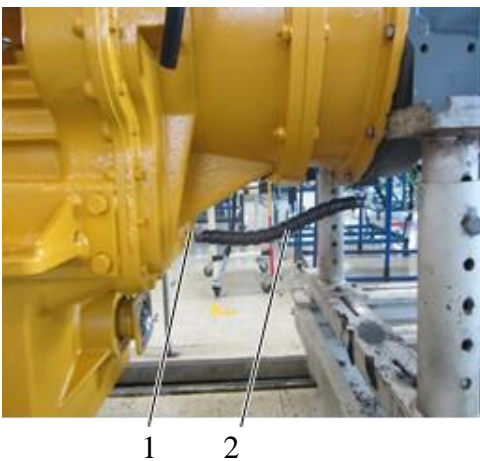

Fig. 2-30
1 Clamp
2 Transmission oil pipe

19. Disconnect the water return pipe from engine.

20. Hang the engine with a lifting rope, open torque converter hood, remove the connecting bolts between flywheel disc and torque converter intermedium ring, remove the connecting bolts and gaskets between flywheel casing and torque converter.

21. Remove the transmission oil pipe.



1

Fig. 2-31
1 Accelerator cable

22. Remove the accelerator cable.



1

Fig. 2-32
1 Flameout cable

23. Remove the flameout cable.



1

2

Fig. 2-33
1 Air compressor pipe
2 Air compressor

24. Remove the air compressor pipe.

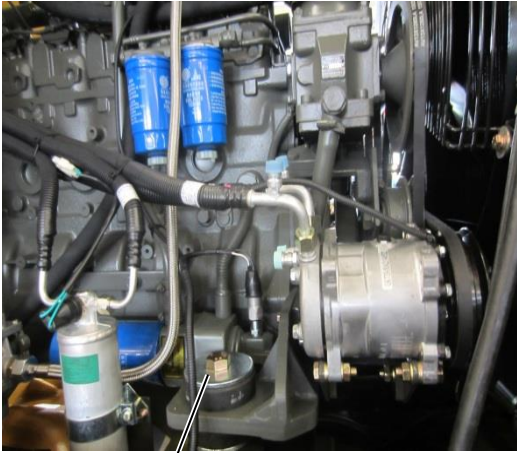

1

Fig. 2-34

1 Fixing bolt of engine support

25. Remove the fixing bolt of engine support.



1

Fig. 2-35

1 Engine

26. Lift down the engine.

★ **ATTENTION:** Ensure all connecting parts are removed from the engine, and no interference involved during lifting.



1

2

Fig. 2-36

1 Intake hose

2 Clamp

27. Disassembly of engine accessories

1 Disassembly of air filter

a) Remove the clamp, disconnect the connection between intake hose and air filter.

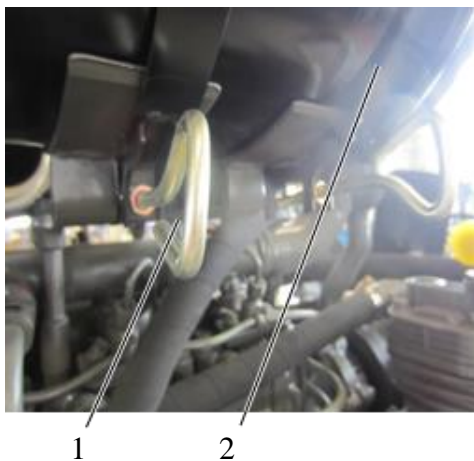

Fig. 2-37

- 1 Fixing clamp of air filter
- 2 Air filter

- b) Remove the fixing clamp of air filter and take down the air filter.

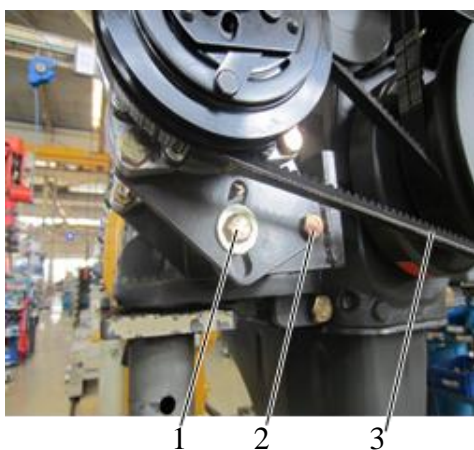

Fig. 2-38

- 1 Adjusting bolt
- 2 Fixing bolt
- 3 V belt

- 2 Disassembly of A/C compressor
 - a) Loosen the adjusting nut and rotate the compressor.
 - b) Take down the V belt.
 - c) Loosen the fixing bolts and take down the compressor assembly.



Fig. 2-39

- 1 Water return valve of fan heater

- 3 Disassembly of water inlet/return valve of fan heater
 - a) Remove the water return valve of fan heater.



1

Fig. 2-40

1 Water inlet valve of fan heater

b) Remove the water inlet valve of fan heater.

262 Assembly of Engine

Refer to the following steps to recover the engine.

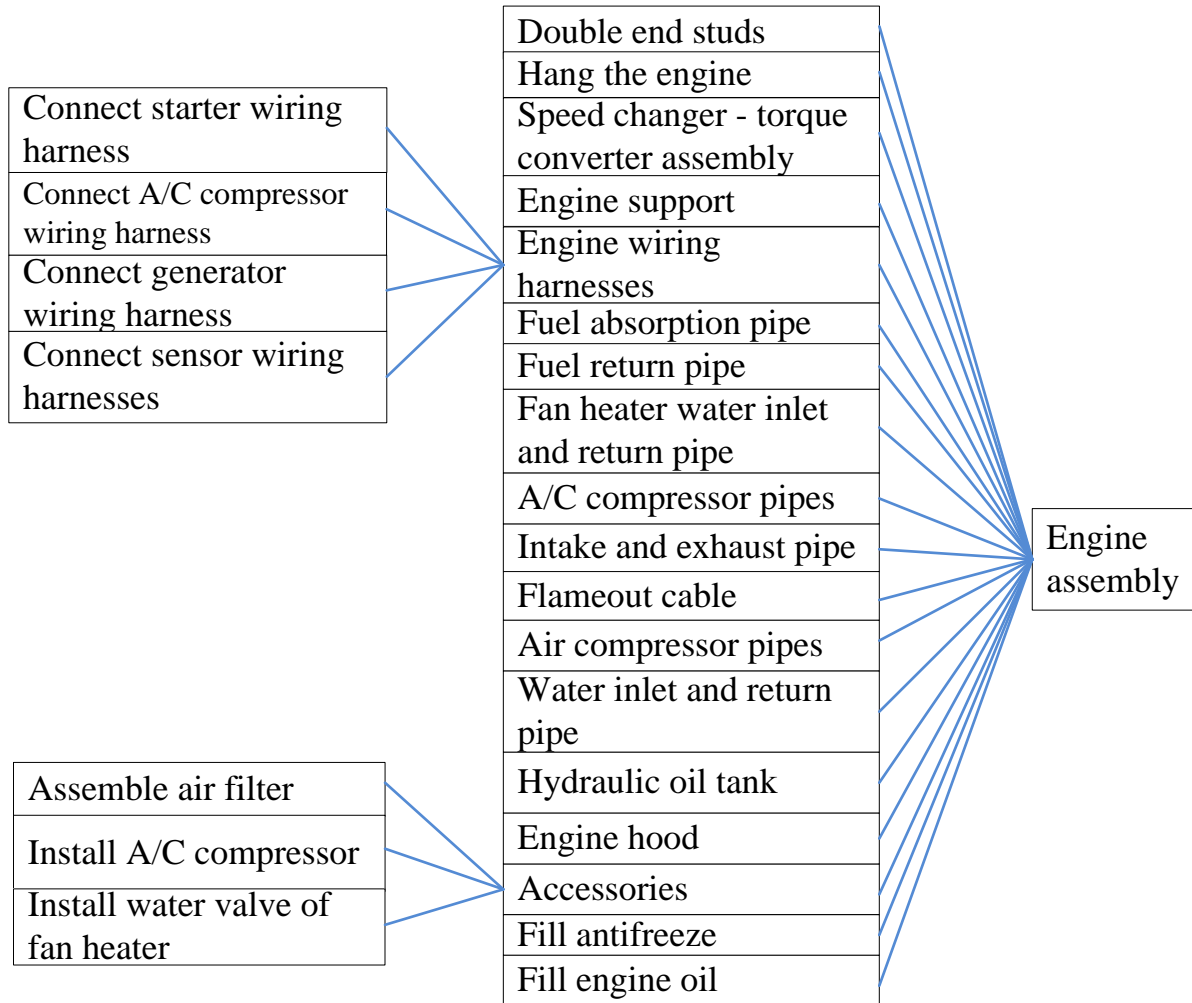

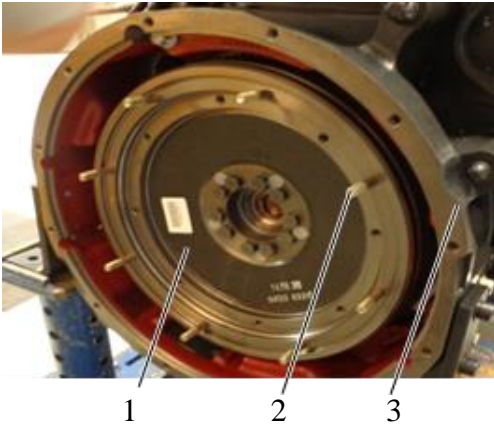

Fig. 2-41

- 1 Flywheel
- 2 Stud
- 3 Flywheel cover

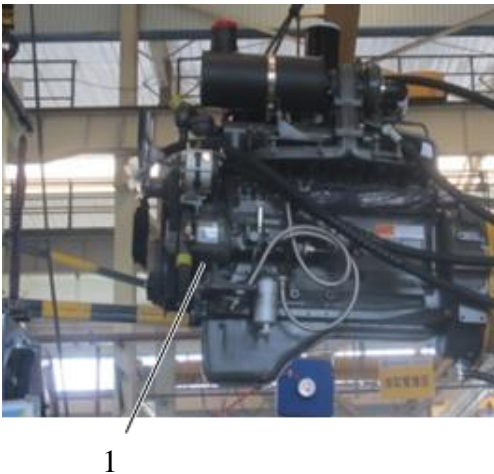

Fig. 2-42

- 1 Engine

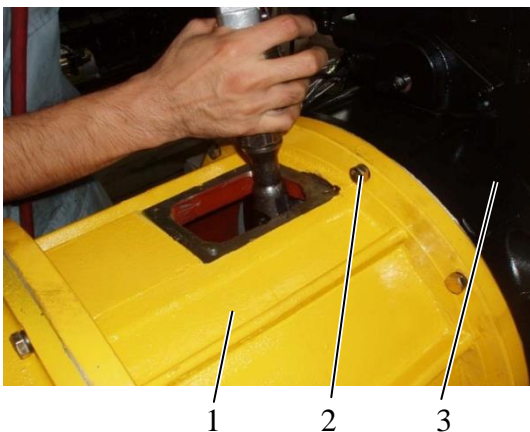

Fig. 2-55

- 1 Speed changer - torque converter assembly
- 2 Fixing bolt
- 3 Engine

1. Pre-tighten the double end studs.

★ **Apply some diesel on the studs before assembling.**

2. Hang up the engine and put it on the frame properly so as to assemble the speed changer – torque converter assembly.

★ **1 Make sure the lifting rope is in good condition.**

2 Notice the installation site, avoid crashing.

3 Nobody is allowed to stand under of engine.

3. Connect the speed changer-torque converter assembly to the engine.

1) Apply a layer of sealant on the end face of engine. Remove the top cover plate of the speed changer-torque converter assembly. Connect the torque converter to the engine with bolts and gaskets.

2) Connect the flywheel to speed changer - torque converter assembly with nuts.

★ **Tighten the all connection bolts in round-group-bolts way. Avoid debris entering into the torque converter when connecting the intermedium ring.**

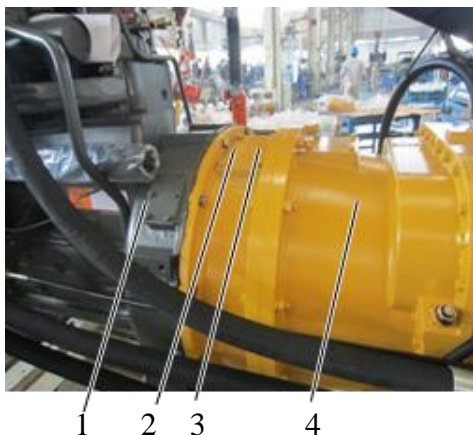

Fig. 2-44

- 1 Flywheel housing
- 2 Cover plate
- 3 Cover plate fixing bolt
- 4 Speed changer - torque converter assembly

4. Install the top cover plate of torque converter.
After check is finished, assemble the top cover plate and tighten it.



1

Fig. 2-45

- 1 Oil return pipe

5. Connect the transmission oil return pipe.

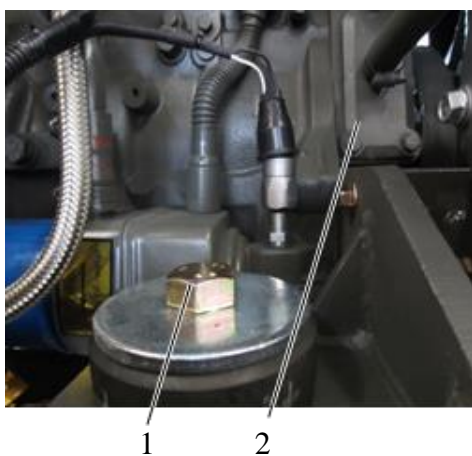

1

2

Fig. 2-46

- 1 Connecting bolt of engine support
- 2 Engine

6. Install and tighten the connecting bolts of engine support.

 Nm 120~200Nm

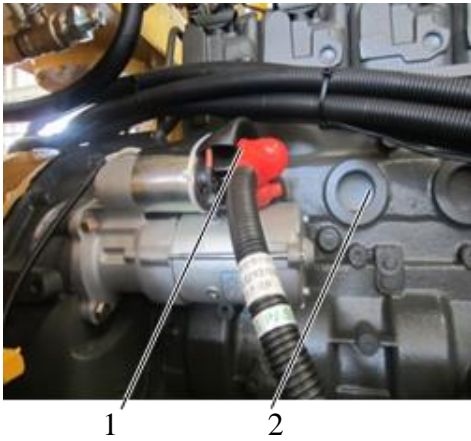

Fig. 2-47

- 1 Starter power wiring harness
- 2 Engine

7. Connect the starterpower wiring harness.

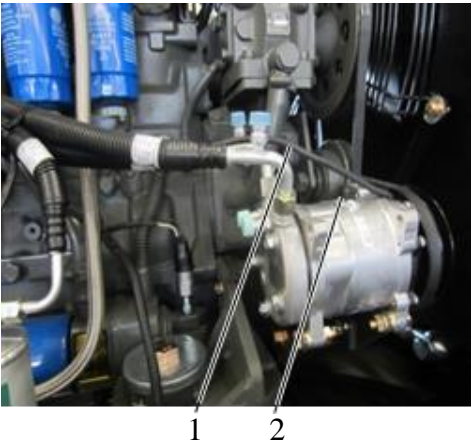

Fig. 2-48

- 1 Compressor wiring harness
- 2 Compressor

8. Connect compressor wiring harness.

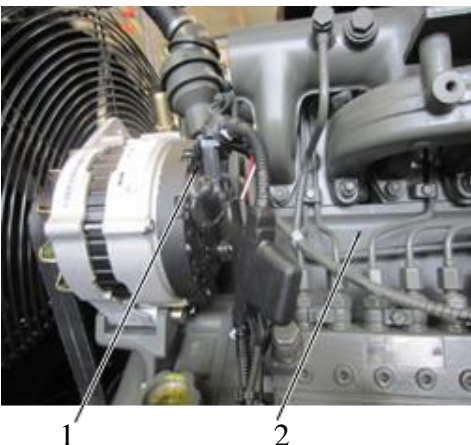

Fig. 2-49

- 1 Generator wiring harness
- 2 Generator

9. Connect generator wiring harness.

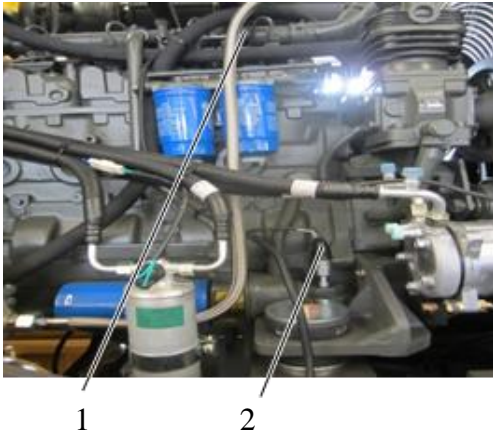

Fig. 2-50

1 Water temperature sensor

2 Engine oil temperature sensor

10. Connect sensor wiring harnesses.

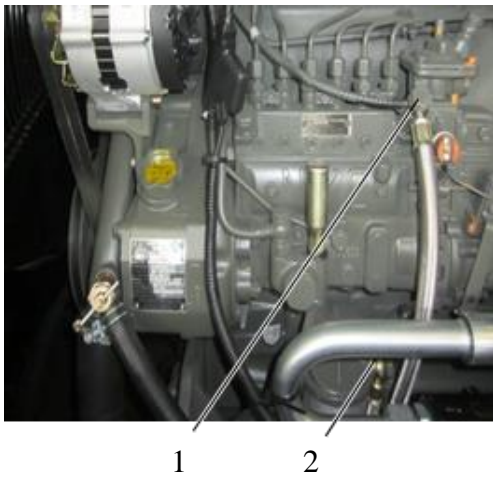

Fig. 2-51

1 Engine fuel return pipe

2 Engine fuel suction pipe

11. Connect engine fuel absorption pipe and return pipe.

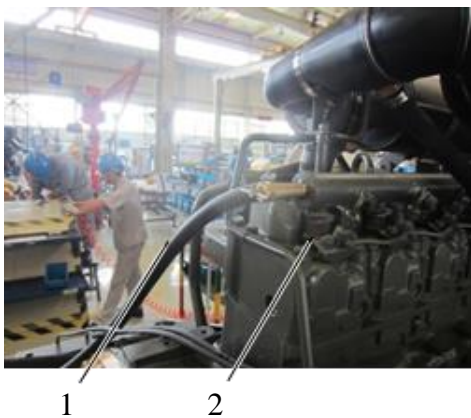

Fig. 2-52

1 Fan heater water inlet pipe

2 Generator

12. Connect fan heater water inlet pipe.



1

Fig. 2-53

1 Fan heater water return pipe

13. Connect fan heater water return pipe.

★ Fasten slowly until the rubber hose is slightly deformed.



1

2

Fig. 2-54

1 Low pressure pipe of compressor

2 High pressure pipe of compressor

14. Connect the high pressure pipe and low pressure pipe of compressor.



1

2

Fig. 2-55

1 Intake hose

2 Clamp

15. Fasten the clamp, connect intake hose and air filter, install the compressor.

Refer to **Assembly of engine accessories** in this chapter.



Fig. 2-56

1 Clamp 2 Air filter

16. Fasten the clamp, tighten the air filter.



Fig. 2-57

1 Silencer 2 Nut
3 Supercharger

17. Install connecting nuts, connect silencer and turbocharger.

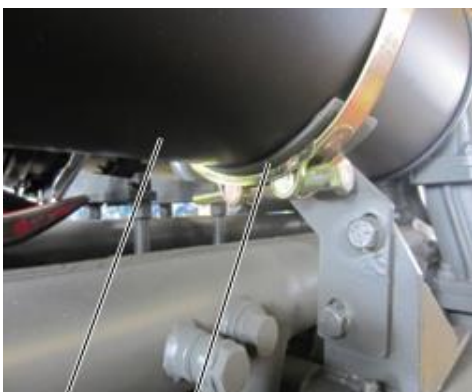
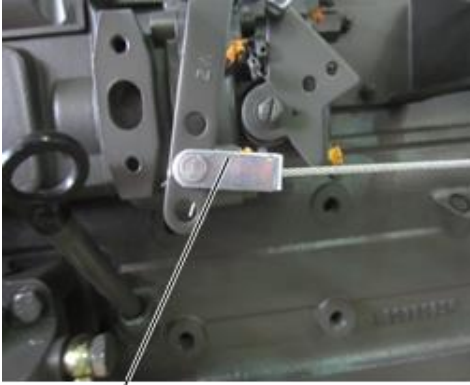

Fig. 2-58

1 Silencer 2 Clamp

18. Fasten the clamp to fix the silencer.



1

Fig. 2-59

1 Accelerator cable

19. Install accelerator cable.



1

Fig. 2-60

1 Flameout cable

20. Install flameout cable.



1

Fig. 2-61

1 Air compressor pipe

21. Install air compressor pipe.

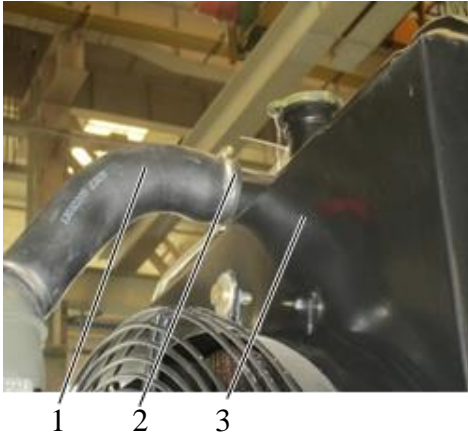

Fig. 2-62

1 Radiator water inlet pipe

2 Clamp

3 Radiator

22. Install radiator water inlet pipe.

★ **Fasten slowly until the rubber hose is slightly deformed.**

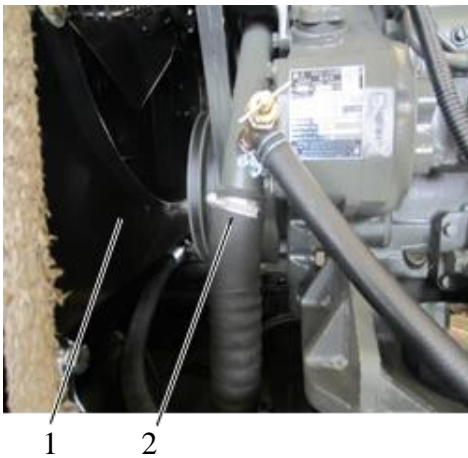

Fig. 2-63

1 Radiator

2 Water return pipe

23. Connect engine water return pipe.

★ **Fasten slowly until the rubber hose is slightly deformed.**



Fig. 2-64

1 Engine

2 Hydraulic oil tank

24. Install hydraulic oil tank.

Refer to **Assembly of hydraulic oil tank** in chapter 9.



1

Fig. 2-65
1 Engine hood

25. Install engine hood.

Refer to **Assembly of engine hood** in chapter 8.



1 2

Fig. 2-66
1 Radiator
2 Coolant adding port

26. Add coolant.



Coolant



1

Fig. 2-67
1 Engine oil filling port

27. Fill engine oil.



Engine Oil

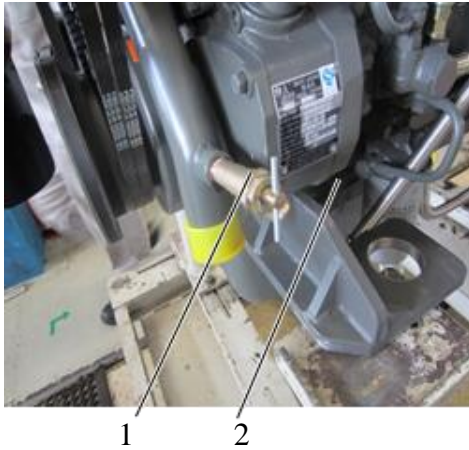

Fig. 2-68
1 Fan heater water valve
2 Engine

28. Assemble engine accessories.

- 1) Install the water valve of fan heater.

★ **ATTENTION:** Coat the water valve with sealant start from the second thread for about 3~5 threads.

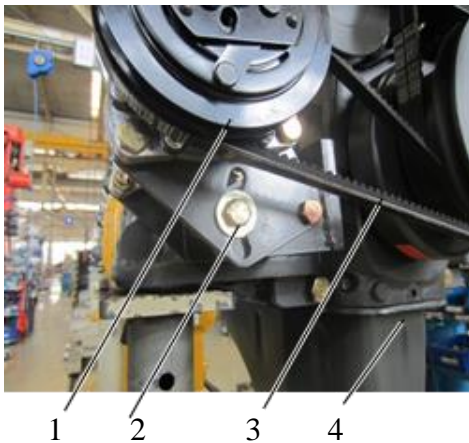

Fig. 2-69
1 Air condition compressor
2 Adjusting nut
3 V belt
4 Engine

- 2) Install A/C compressor.

Refer to **Assembly of compressor in A/C system.**



1 2
Fig. 2-70
1 Air filter
2 Clamp

- 3) Install the air filter.

a) Pretighten the air filter and fix the clamp.

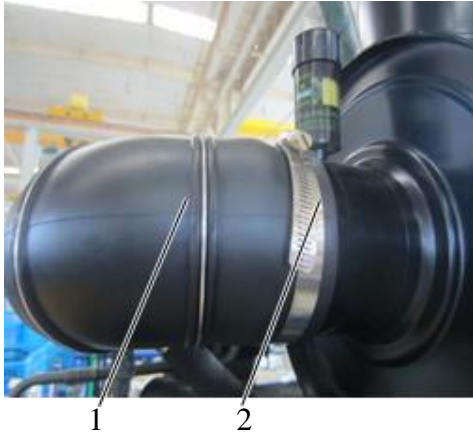

Fig. 2-71

1 Intake hose

2 Clamp

b) Install lock clamp between intake hose and air filter.

★ **Fasten slowly until the rubber hose is slightly deformed.**



1 2

Fig. 2-72

1 Air filter

2 Clamp

c) Fasten lock clamp of air filter.

27 Disassembly and Assembly of Fuel Tank

271 Disassembly of Fuel Tank



Fig. 2-73

1 Tire

2 Wood block

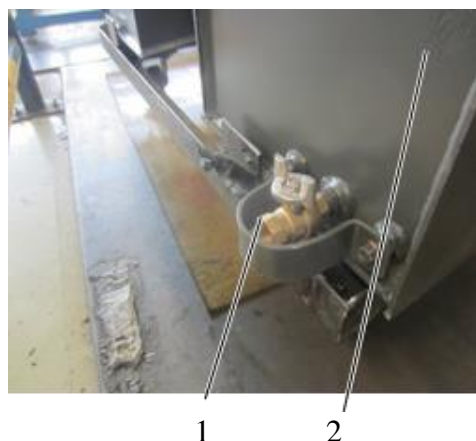

Fig. 2-74

1 Ball valve

2 Fuel Tank

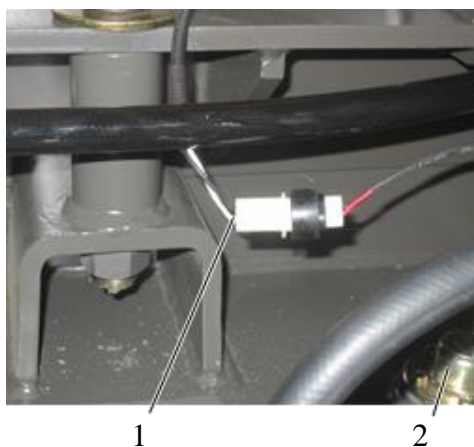

Fig. 2-75

1 Oil level sensor connector

2 Oil level sensor

1. Start the machine and park it on level capacious ground. Lower the bucket and flat it on ground. Pull up the parking brake and wedge the front and rear tires with wood blocks, turn of main power 5min later.

★ **ATTENTION: Do the disassembly after the loader is cooled.**

2. Loosen the screw plug on the bottom of tank and drain the oil. Contain the oil with clean vessel and covers it to avoid falling sundries.

★ **ATTENTION: Fuel oil is inflammable. In the processes of maintaining, the fire is forbidden and the place should be far away from fire. At the same time, prevent the generation of fire, for example: Bumping brings spark.**

3. Remove oil level sensor wiring harness of fuel tank.



Fig. 2-76

- 1 Fuel absorption pipe
- 2 Fuel Tank

- 4. Loosen the clamp of fuel absorption pipe and take down the pipe from fuel tank.



Fig. 2-77

- 1 Fuel return pipe

- 5. Remove the bolts and disconnect the fuel return pipe.



Fig. 2-78

- 1 Fastening bolt * 3

- 6. Hang the fuel tank, disassemble the fastening bolts and remove fuel tank from rear frame.



1

Fig. 2-79
1 Fuel tank

7. Lift down the fuel tank.

★ **ATTENTION:** Ensure all connecting parts are removed from the tank, and no interference involved during lifting.



1

Fig. 2-80
1 Fuel tank

272 Assembly of Fuel Tank

1. Lift and assemble the fuel tank.

Clean the fuel tank. Lift the fuel tank assembly to rear-bottom site of the rear frame.



1

Fig. 2-81
1 Fastening bolt

2. Fix the fuel tank on the rear frame with bolts.

 Nm 120~180N m



1

Fig. 2-83

1 Fuel return pipe

2 Hollow bolt

3. Connect engine fuel return pipe and tighten it.



1

Fig. 2-83

1 Fuel absorption pipe

4. Connect fuel absorption pipe to the tank and fix it with clamp.



1

2

Fig. 2-84

1 Oil level sensor connector

2 Oil level sensor

5. Install the oil level sensor on the fuel tank.

Fig. 2-85

1 Fuel adding port 2 Fuel tank

6. Add fuel.



Keep away from open flame when adding.

28 Disassembly and Assembly of Radiator

281 Disassembly of Radiator

1. Open the drain valve on the bottom of radiator. Drain out the coolant and contain them with clean vessel.

⋮ Antifreeze

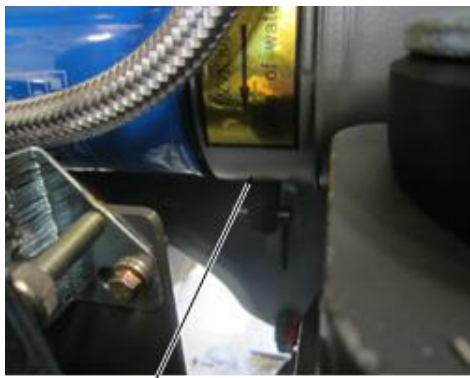
Fig. 2-86

1 Water drain hose

Fig. 2-87

1 Engine hood

2. Hang the engine hood up.

Refer to **Disassembly of engine hood** in chapter 8.



1

Fig. 2-88

1 Transmission oil return pipe

3. Disconnect the transmission oil return pipe from radiator.

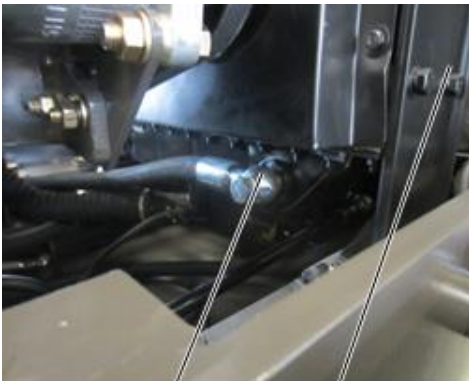

1

2

Fig. 2-89

1 Transmission oil inlet pipe
2 Radiator

4. Disconnect the transmission oil inlet pipe from radiator.



1

2

Fig. 2-90

1 Hydraulic oil return pipe
2 Hydraulic oil inlet pipe

5. Disconnect the hydraulic oil pipe from radiator.

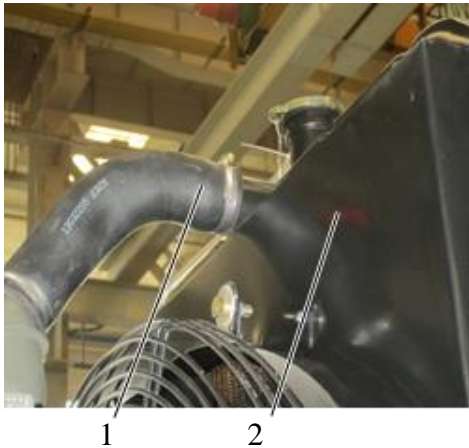

Fig. 2-91
1 Radiator water inlet pipe
2 Radiator

6. Disconnect the radiator water inlet pipe from radiator.

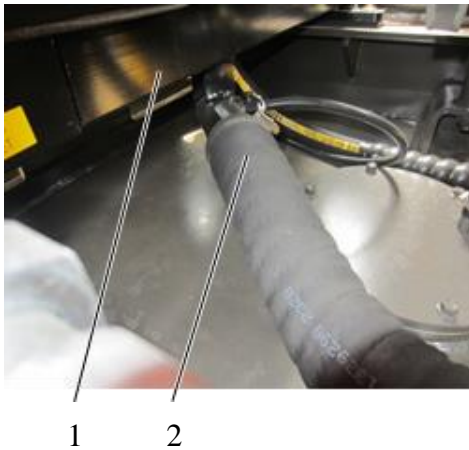

Fig. 2-92
1 Radiator
2 Radiator water outlet pipe

7. Disconnect the radiator water outlet pipe.

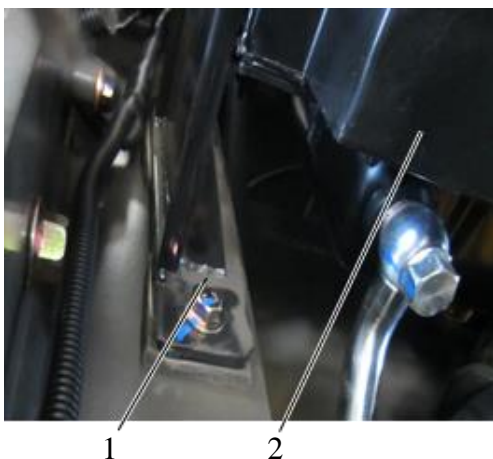

Fig. 2-93
1 Fixing bolt
2 Radiator

8. Remove the fixing bolts.



Fig. 2-94
1 Radiator

9. Lift the radiator down.

★ **ATTENTION:** Ensure all connecting parts are removed from the radiator, and no interference involved during lifting.



Fig. 2-95
1 Radiator

282 Assembly of Radiator

1. Clean the radiator and lift it up to place it on relevant position of the loader rear frame.



Fig. 2-96
1 Bolt 2 Radiator

2. Fasten the fixing bolts of radiator.

 Nm 15~35Nm

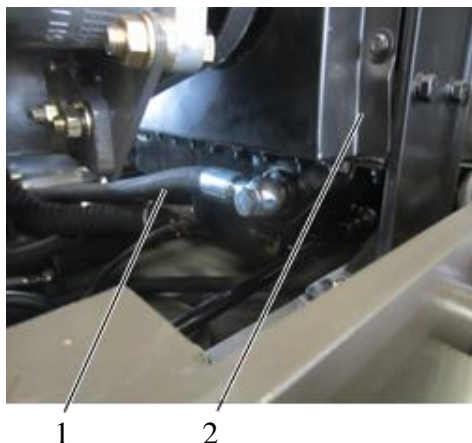

Fig. 2-97
 1 Radiator water return pipe
 2 Radiator

3. Connect the radiator water return pipe.

★ **Fasten slowly until the rubber hose is slightly deformed.**

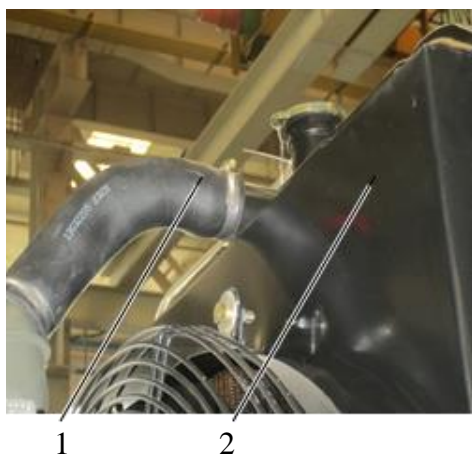

Fig. 2-98
 1 Radiator water inlet pipe
 2 Radiator

4. Connect radiator and water inlet pipe.

★ **Fasten slowly until the rubber hose is slightly deformed.**

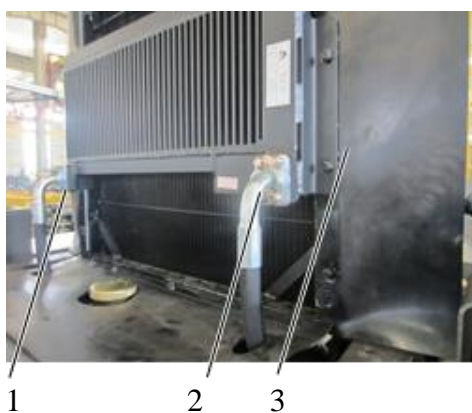

Fig. 2-99
 1 Hydraulic oil return pipe
 2 Hydraulic oil inlet pipe
 3 Radiator

5. Connect hydraulic oil inlet pipe and return pipe to radiator.

 Nm 20~30Nm

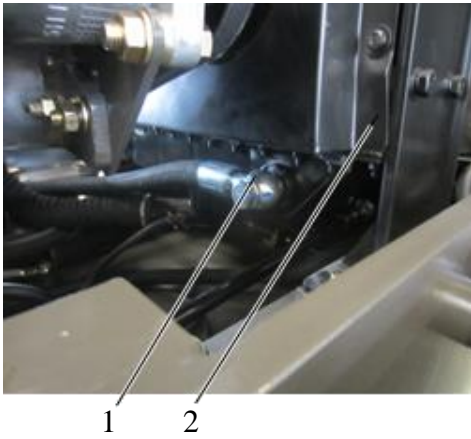

Fig. 2-100

- 1 Transmission oil inlet pipe
- 2 Radiator

6. Connect the transmission oil inlet pipe.

 Nm 120~160Nm

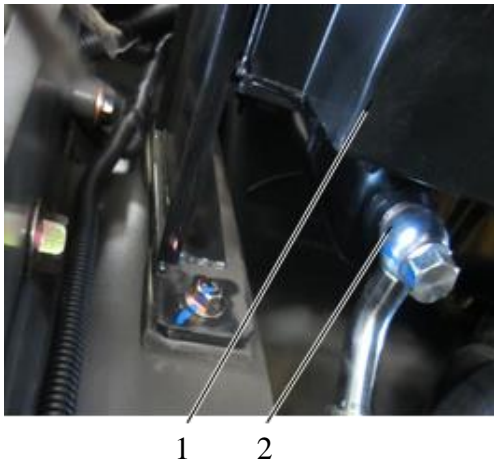



Fig. 2-101

- 1 Radiator
- 2 Transmission oil return pipe

7. Connect the transmission oil return pipe.

 Nm 120~160Nm



1
Fig. 2-102
1 Engine hood

8. Assemble the engine hood.

Refer to **Assembly of engine hood** in chapter 8.

29 Diagnosis and Troubleshooting of Engine System Common Faults

291 Engine Fails to Start

Caused by starting system

- 1 Power shortage of storage battery.

Solution: Check the battery carefully, recharge or replace it.

- 2 Damaged starting motor.

Solution: repair or replace the motor.

Caused by oil supply system

- 1 There is air in the oil system.

Solution: Unchoke the oil circuit, tighten all joints and discharge air.

- 2 Blocking of oil system.

Solution: Unchoke the oil circuit, tighten all joints and discharge air.

- 3 The diesel filter element is particularly dirty.

Solution: Replace the filter element.

- 4 Serious wear damage of plunger/delivery valve.

Solution: Repair the fuel pump professionally.

- 5 Damaged low pressure fuel pump.

Solution: Replace the fuel pump

Adjustment factors

- 1 Dislocation of fuel injection advance angle.

Solution: Adjust the fuel injection advance angle.

- 2 Change of valve clearance.

Solution: Check and adjust valve clearance.

- 3 Oil shortage when starting

Solution: Check the fuel pump professionally.

292 Engine Power is Not Sufficient

- 1 Blockage of fuel filter or fuel pump oil inlet pipe connector filter screen.

Solution: Clean or replace it/them.

- 2 Low injection pressure or bad atomization.

Solution: Troubleshoot the injector or replace inject nozzle matching parts.

3 Serious wear damage of precise injection nozzle matching parts.

Solution: Regulate oil supply or troubleshoot plunger and barrel assembly.

4 Air infiltrate into the fuel system.

Solution: Discharge air of the fuel system.

5 Incorrect fuel injection advance angle.

Solution: Adjust the angle according provisions.

6 Non-uniform oil supply of each cylinder.

Solution: Adjust oil supply.

7 Blockage of air filter.

Solution: Clean or replace the filter element.

293 Exhaust Exceptions (Black Smoke, White Smoke, Blue Smoke)

The engine gives off blue smoke

1 High engine oil level of engine sump.

Solution: Drain redundant engine oil, and make sure the oil level is within specified range.

2 Diesel flows into oil sump due to oil-fuel injector needle-valve poorly sealed or stuck in open position.

Solution: Clean and adjust the injector or replace the needle valve matching parts.

3 Damaged fuel pump plunger bushing sealing ring (P pump), or bad sealing between plunger bushing and pump body, the fuel flows into oil sump along engine oil passage.

Solution: Replace the sealing ring.

4 Damaged valve oil seal or excessive clearance between the valve and tube.

Solution: Replace all faulted valves, pipes and oil seal (the oil seal must be replaced once being disassembled; if the clearance meets the requirements after the valve is replaced, you can spare the tube).

5 Damaged sealing ring of turbocharger, engine oil burns after enters into the combustion chamber along air inlet passage.

Solution: Repair or replace.

The engine gives off white smoke

1 There is moisture in the fuel system.

Solution: Clean the fuel tank and filter, and use qualified diesel oil.

2 Abrasion of cylinder valve.

Solution: Replace it.

- 3 Bad atomization of injected fuel, the fuel fails to burn in the combustion chamber.

Solution: Adjust the injector and fuel supply advance angle.

The engine gives off black smoke

- 1 Exhaust back pressure is too high or exhaust pipeline is blocked.

Solution: Reduce bend positions of pipeline; dust out the silencer.

- 2 The injection lags

Solution: Adjust fuel injection advance angle.

- 3 The injector doesn't work normal or being damaged.

Solution: Dismantle, clean and check.

- 4 Poor quality of diesel or wrong brand.

Solution: Replace the diesel.

- 5 Severe wear of cylinder liner and piston group.

Solution: Replace worn parts

294 Engine Oil Pressure is Too High or Too Low

Engine oil pressure is too high

- 1 Malfunctioned engine oil display device.

Solution: Replace the display device.

- 2 High viscosity of engine oil

Solution: Choose specified brand engine oil, and take preheating action when starting the machine in winter.

- 3 Too little gap in force-feed lubricating positions or blocked engine oil filter.

Solution: Adjust the gap, clean or replace the filter.

- 4 Misadjusted pressure restrict valve.

Solution: Readjust the spring force of the valve, so the engine oil pressure can drop to specified value.

Engine oil pressure is too low

- 1 Abrasions of engine oil pump or damaged sealing gasket.

Solution: Repair the pump and replace the gasket.

- 2 The suction oil flow reduces

Solution: Check oil capacity, add engine oil and clean the suction filter.

- 3 Large engine oil leakage.

Solution: Check whether the lubricating pipe is broken; check and adjust the fitting clearance of bearings in crankshaft and camshaft as required.

4 Blockage of engine oil filter or cooler.

Solution: Check and clean engine oil filter and cooler.

5 Low viscosity of engine oil

Solution: Choose specified brand engine oil.

6 Misadjusted pressure restrict valve.

Solution: Clean the valve; readjust or replace the spring.

7 Low displaced engine oil pressure.

Solution: Check and replace engine oil pressure sensor and pressure gauge.

295 Large Consumption of Engine Oil

1 Improper engine oil viscosity.

Solution: Choose proper engine oil.

2 High negative pressure in combustion chamber, result in engine oil spraying up to combustion chamber.

Solution: Examine the reason for high negative pressure and fix it.

3 Change of rotating speed and operating mode.

Solution: Test showed that with the increase of rotating speed, engine oil consumption rises obviously, operate the engine according to the rules.

296 High Coolant Temperature

1 Improper selection of coolant or shortage of cooling water.

Solution: Choose suitable coolant and add to specified level.

2 Blockage of water radiator.

Solution: Put the radiating fins back to their original positions with stalloy carefully, after they return to flat shape, clean them with compressed air or water gun.

3 Wrong indication of water thermometer or warning light.

Solution: Use the water thermometer to measure the temperature of water temperature sensor area, see whether the measured temperature is consistent with actual value.

4 Low rotating speed of fan, the blades are deformed or installed backwards.

Solution: Loosened rubber belt will lead to slipping, which result in low rotating speed of fan. Adjust the belt if necessary; if the rubber layer aged, damaged or fractured, replace it. If the blades are

deformed, replace them.

5 Malfunction of water cooling pump.

Solution: Replace the pump.

6 Malfunction of thermostat.

Solution: Replace the thermostat.

7 Damaged cylinderhead gaskets.

Solution: Replace them.

8 Overloaded operation of diesel engine.

Solution: Lower the load of engine.



Service Manual

LG936L

Version:0310



3 Electrical and Information Systems

CONTENTS

3	Electrical & Information System.....	3-1
31	Description of Electrical System.....	3-1
311	Working Precautions for Electrical System	3-1
312	Electrical System Description	3-4
32	Power Supply and Starting System	3-5
321	Battery.....	3-6
322	Power Switch.....	3-12
323	Starting Switch.....	3-12
324	AC Generator.....	3-13
325	Starter Motor.....	3-16
33	Instrument Monitoring System.....	3-20
331	Instrument Panel	3-20
332	Sensors.....	3-22
34	Lighting System.....	3-24
341	Front Combination Lamp Circuit	3-24
342	Front Lamp Circuit	3-25
35	Reverse Alarm System & Electric Horn System	3-27
351	Reverse Alarm System	3-27
352	Electric Horn System.....	3-28
36	Wiper and Cleaning System	3-29
37	Wiring Harness Routing	3-31
38	Fault Inspection and Diagnosis	3-41
381	Basic Method to Fault Inspection and Diagnosis.....	3-41
382	Common Fault Diagnosis and Troubleshooting.....	3-44

3 Electrical & Information System

31 Description of Electrical System

311 Working Precautions for Electrical System

⚠ No modification to electrical system is allowed without the permission of our company.

Modification can impact the wheel loader function, and even lead to serious personal injury and loader damage.

⚠ During electrical system operation, the carelessness can lead to serious personal injury and loader damage.

Before operating the electrical system, always observe the following and relevant descriptions carefully.

⚠ To replace the electrical system parts, always use **SDLG** accessories.

Battery

1. While troubleshooting the electrical system, always use the fully charged or fully featured battery.
2. While installing the battery, make sure that the battery polarity connection is correct.
3. While replacing the battery, make sure that the capacity of the new battery is equal to that of the replaced one.

Power switch

1. After the engine flames out, if the power switch is not turned off, many parts in the circuit are still charged, which can lead to accidental fire or other wheel loader damages! Therefore, always turn off the power switch before any of the following situations occurs!
 - Wheel loader will stop working for a long time
 - Operator will leave the wheel loader for a long time
 - Oil stain on the wheel loader will be removed
 - Wheel loader will be subject to welding
 - Fastening the battery circuit
 - Maintaining or replacing the battery
 - When a fire or other accident occurs

Fuse

1. To replace the fuse, always apply fuses of the same specification. Use of copper wire for emergency is not allowed. The blade fuse and flat plate fuse adopted by this product must strictly conform to the relevant specifications in QC/T 420 Fuse-links for motor vehicles. Therefore, if a fuse has to be replaced during maintenance, please use SDLG accessories as far as possible. Only as a last resort should the accessories be purchased from market with great caution! Inferior fuses can result in immeasurable damage to the wheel loader.

Wiring harness or conductor

1. Bundle up the wiring harness and conductor properly and avoid any forcible wiring harness folding and bending.
2. Keep the wiring harness and conductor as far away from the moving parts as possible in case of snap break and wear.
3. Prevent the wiring harness and conductor against friction with sharp metal edges.
4. Keep the wiring harness and conductor as far away from oil and water as possible.
5. Keep the wiring harness and conductor as far away from hot parts as possible (e.g. engine block).
6. When the wiring harness or conductor is found to be worn, bundle it up or replace it immediately, and fix the wiring harness to a proper location that is free from wear.

Connector

1. Connect the connector properly: While connecting the connectors (especially when the connectors are relatively concentrated), please observe the letter identifications of connectors carefully in case of wrong connection, which can lead to many unpredictable faults, and even fire on complete wheel loader.
2. While separating the connector, please hold the connector body and press its lock latches to separate the connector in two directions. Do not hold the conductor and pull the connector out forcibly. While connecting the connector, always observe the lock latch for snap-fit.
3. While overhauling the waterproof connector, pay special attention to prevent oil and water from entering into the connector. Otherwise, the connector cannot be connected again unless they are cleaned and dried.

Pressure switch

1. Compressed air and fluid can result in personal injury! If a pressure switch has to be replaced during maintenance, please make sure to release the pressure. CAUTION: While removing the pressure switch, wear the goggles and gloves.

Sensor

1. The high-temperature and high-pressure oil or water can result in personal injury! To replace the sensor, shut down the engine first, and wait until the engine and transmission housings are sufficiently cooled down.

Electrical element

The electrical equipment is sensitive and can be easily damaged by the electromagnetism or the static electricity from the tool or human body. Therefore, while doing the relevant electrical element operation, the following instructions should be observed:

1. When a certain electrical element is electrified, the connection to this element should not be disconnected. Otherwise, the electrical element can be damaged.
2. Before maintaining the electrical system, use a tool to contact a metal mechanical part connected to the frame to discharge the static electricity from the tool.
3. Do not touch the plug pin on the electrical element.
4. While maintaining the electrical system, do not touch the circuit board. If necessary, only hold the circuit board edge.
5. Do not touch any individual electrical element.
6. While replacing the element, make sure that the ground wire is safely connected.

Welding

1. Disconnect the terminals of battery to prevent explosion of battery.
2. After the repair is completed, be sure to install the wire connectors of the computer control panel, otherwise the machine will not start and move.
3. For welding, sparks may fall directly on rubber hoses, wires or pressure pipe, and these pipes may suddenly rupture, wire insulation may be damaged, so these pipes should be covered.

★ ATTENTION

Any complete circuit should consist of power supply, fuse, switch, control device, electrical device and conductor, etc. Keep the integrity of the circuit when conducting relevant electrical operation.

312 Electrical System Description

Electrical system includes battery, starter motor, AC generator, gauges, switches, lamps, air conditioning circuits and other electrical equipment.

Machine system voltage is DC 24V, containing two batteries 12V in series. Negative pole is grounded, and the line applies single system. As to the relationship and working principle between electrical equipment, please carefully read the electrical system circuit diagram.

Power switch is located near the battery. When the switch turns to "○" position, the vehicle power is off; when the switch turns to "I" position, the vehicle power is turned on. For parking vehicles for a long term, turn off the power switch. Relays and fuses are mainly located in the distribution box behind operator's seat, after the cover of distribution box is removed, you can see the relays in distribution boxes can be interchanged.

32 Power Supply and Starting System

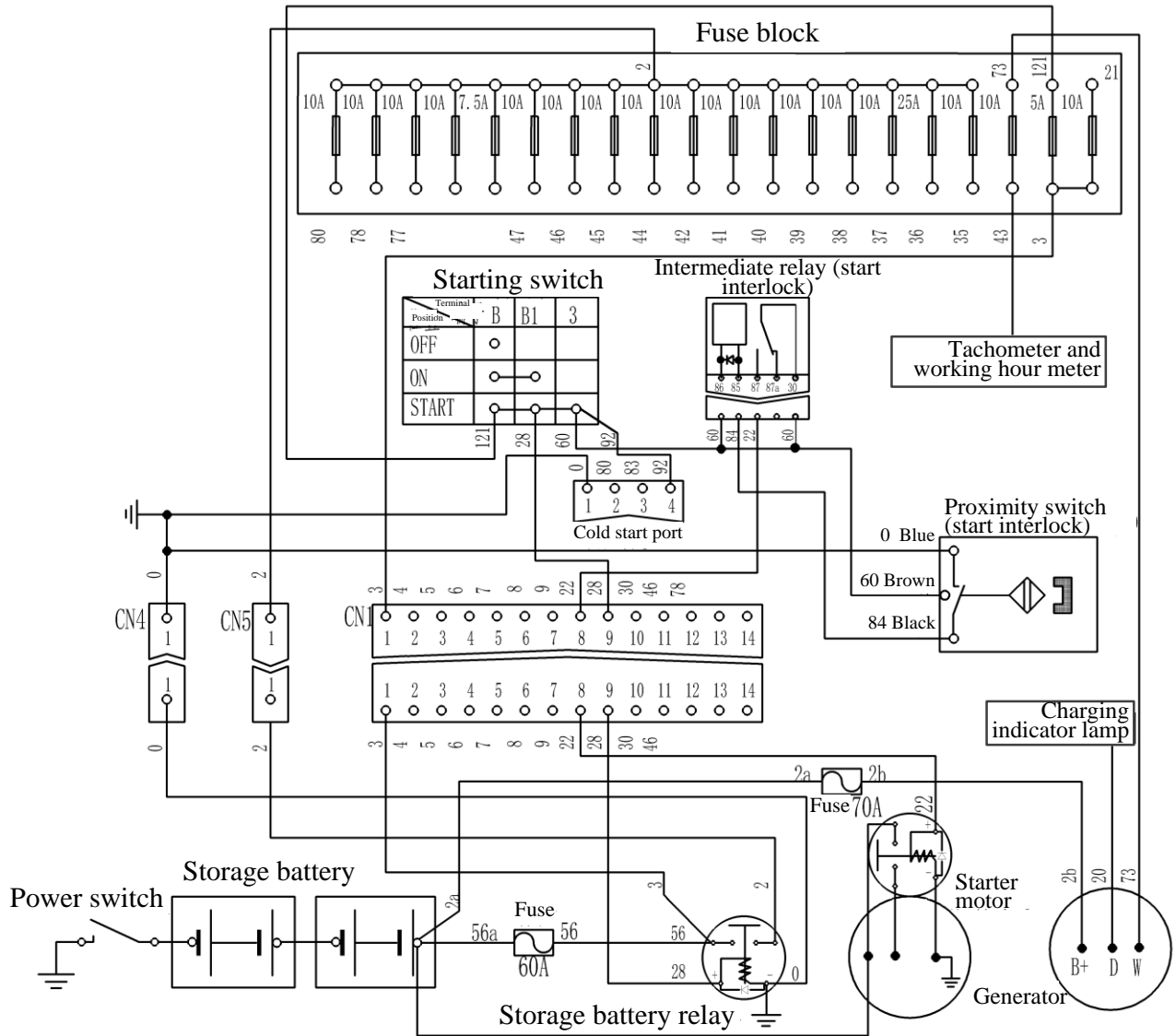

Fig. 3-1 Power supply and starting system

Principle description:

1. Turn on the power switch, and the voltage of two batteries (connected in series with 24V rated voltage) will pass through #56a conductor → fuse 60A → #56 wire → storage battery relay → #3 wire → connector CN1 → #3 wire → fuse block → #121 wire → contact point B of starting switch.
2. Turn on the starting switch (turn the starting switch to ON), terminal B and B1 will be connected, and current will pass through #28 wire → connector CN1 → storage battery relay coil, then the coil of storage battery relay will be electrified, and the contact will be closed, #56 wire and #2 wire will be connected, the voltage will pass through #2 wire → connector CN5 → #2 wire → fuse block → the complete loader electrical load will be powered on.

- Turn the starting switch to START, contact points B, BR and 3 will be connected, so will #121, #28 and #60, #92 conductors. The voltage will pass through #60 wire to intermediate relay and proximity switch. While closing the proximity switch, the coil of intermediate relay will be electrified, and the contact will be closed. At this point, the voltage will pass through #22 wire, and connector CN1 to starter motor.

321 Battery

The complete loader applies two water-free and maintenance-free lead acid batteries. A single battery can supply 200A~600A starting current to the starter motor in a short time (5~10s).

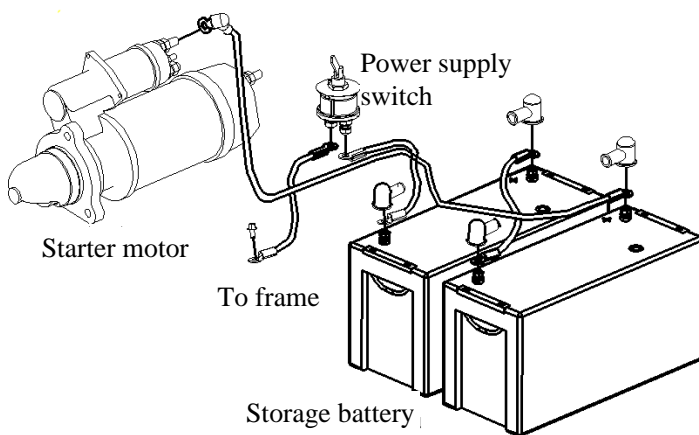

Main parameters (single battery)

Rated voltage: 12V

Rated capacity of 20h: 120A.h

Reserve capacity: 230min

Low-temperature starting current: 850A

Fig. 3-2 Storage battery

Main battery functions in a circuit:

- The battery can be a reversible DC power supply connected to the generator in parallel to power on the electrical devices.
- The battery can supply large starting current to the starter motor in a short time to start the engine.
- The battery, also equivalent to a large capacitor, can absorb the overvoltage in the circuit at any time, thus protect the electrical parts from breakdown.

Features of maintenance-free battery

The maintenance-free battery, also known as MF battery, means that maintenance operations such as filling distilled water, checking electrolyte level and electrolyte concentration are not required during the period of normal use.

An electrolyte densitometer is installed inside the maintenance-free battery, which can automatically display the electricity condition of battery and the electrolyte level. The sight glass of the densitometer can display in the following three colors:

- **Green:** The electricity amount is above 65% - electricity is sufficient and the battery can work normally.
- **Black:** The electricity amount is below 65% - insufficient electricity and supplementary charge is required.
- **White:** The battery needs to be scrapped.

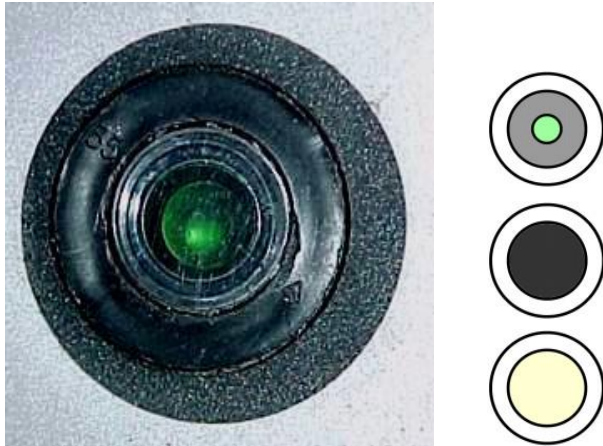

Fig. 3-3 Battery eye

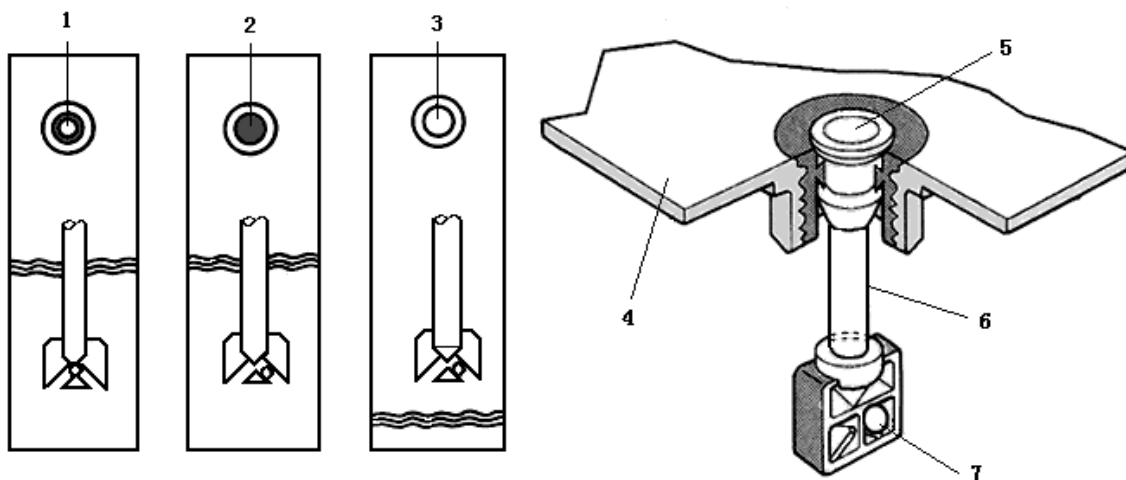

Fig. 3-11 Principle of battery eye

1 Green 2 Black 3 White 4 Battery cover 5 Sight glass
6 Optical SOC indicator 7 Small green ball

Charging specifications for battery

If the battery is stored for a long time (for example, out-of-service for more than 6 months since the delivery) or the battery status indicator turns black because the battery is over discharged due to the wheel loader charging system failure or other misoperation, the following methods are recommended for charging:

At room temperature, connect the battery positive and negative to DC generator output positive and negative respectively, and charge the battery for 16-24h at a constant voltage of $16.0 \pm 0.1V$. During

the constant voltage charging, if the battery temperature exceeds 45 °C or the charging current exceeds 25A, the voltage should be lowered appropriately and the charging time extended.

★ ATTENTION

The battery should be charged in a well-ventilated area, and pay attention to the electricity safety.

Battery open-circuit voltage inspection

Inspection content		Diagnosis	Solution
Voltage	12.5V and above, Battery eye displays green	Normal	Load test
	12.4~11V, Battery eye displays black	Undercharge	Charge
	10.5V and under	1 Over discharge (battery eye displays black)	Charge
		1 Short circuit (battery eye mostly displays green)	Replace
Load test	Green range	1 Open circuit (battery eye mostly displays black)	Replace
		Normal	—
	Yellow range	Undercharge	Charge
	Red range	Undercharge	Charge
Short circuit or open circuit		Replace	



Fig. 3-5 Storage battery tester

Diagnosis and troubleshooting of storage battery common faults

Fault	Phenomenon	Causes	Solution
Undercharge	<ol style="list-style-type: none"> 1. Battery voltage is under 12V. 2. Difficult to start, the lighting is poor. 3. Test the battery with tester and the pointer is in yellow or red range. 	<ol style="list-style-type: none"> 1. Low voltage regulator set value. 2. Electrical load is greater than charge level. 3. Idle traveling or traveling at night. 4. Overloaded battery. 5. Start too many time in a short distance, idle traveling. 6. Engine transmission belt is loose or circuit failure. 7. Erosion of battery connector. 	<ol style="list-style-type: none"> 1. Adjust electrical configuration of the loader. 2. Adjust charging voltage to 13.8~14.5V (charging voltage for two batteries in series should be 27.6~29V). 3. Recharge the battery.
Overcharge	<ol style="list-style-type: none"> 1. Battery box is deformed. 2. There is acid mist on battery box. 3. Lead powder on polar plate is easy to fall off. 4. Battery eye displays white. 	<ol style="list-style-type: none"> 1. High voltage regulator set value. 2. Recharging too long. 3. Recharge voltage exceeds 16.2V. 	<ol style="list-style-type: none"> 1. Adjust charging voltage (Refer to above-mentioned requirements). 2. Replace the battery.
Over discharge	<ol style="list-style-type: none"> 1. Battery voltage is under 11V. 2. Battery eye displays black. 3. Battery inner polar plate turns white 	<ol style="list-style-type: none"> 1. Charging circuit failure. 2. Short circuit of machine electrical system. 3. Electrical appliance is not turned off when the machine is not in use. 4. Negative wire is not disconnected for long term parking. 	<ol style="list-style-type: none"> 1. Adjust the electrical system 2. Recharge the battery. 3. Replace the battery if necessary.
Short circuit	<ol style="list-style-type: none"> 1. Battery voltage is about 10.5V, and battery eye displays green. 2. Self-discharge is huge 	<ol style="list-style-type: none"> 1. Manufacturing defect in battery. 2. Overuse, overcharge or high temperature that results in polar plate short circuit. 	Replace the battery.

Open circuit	<ol style="list-style-type: none"> 1. Battery voltage is unstable. 2. Battery voltage is 0V when discharging. 3. Unable to charge or electrolyte rise when recharging. 	Manufacturing defect in battery.	Replace the battery.
Inverse charge	<ol style="list-style-type: none"> 1. Battery voltage is negative. 2. The color of positive and negative polar plate is opposite. 	Negative and positive are inversely connected when recharging.	Replace the battery.
Battery burst	Battery container burst and acid splashing out.	<ol style="list-style-type: none"> 1. Rack of fusion or short circuit in battery. 2. Low electrolyte level. 3. Battery is overcharged 4. Vent hole is blocked. 	Replace the battery.

Fault diagnosis process for maintenance-free battery

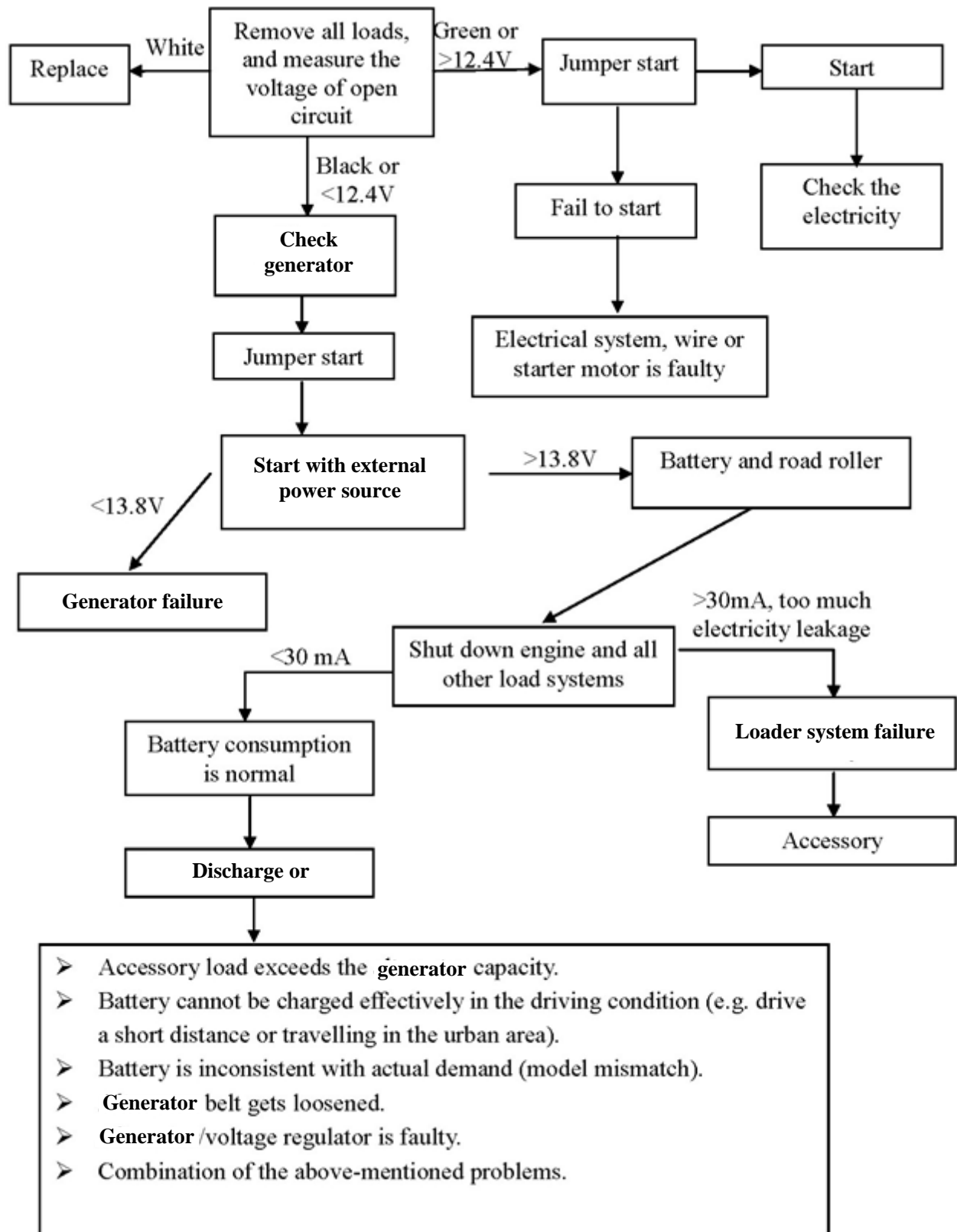

322 Power Switch

The power switch controls the battery negative and frame (ground) for connection and disconnection. Turn on the power switch, the battery negative will be connected to the frame, and turn on the electric lock, the complete loader electrical load will be electrified; turn off the power switch, the battery negative will be disconnected from the frame and the circuit will fail to form a loop, even if the electric lock is turned on, the complete loader will not be electrified, thus cannot be started.



Main parameters

Voltage: 24VDC

Continuous current for main contact point: $\leq 200A$

Transient current (5s): 1200A

Working temperature: $-40^{\circ}C \sim 120^{\circ}C$

Duty rating: Current $\leq 200A$ Continuous working

Current $\leq 1200A$ Conduction time is 5s.

Fig. 3-6 Power switch

WARNING

1. **When the wheel loader stops working, please note to turn off the power switch in case of electric leakage or other accidents!**
2. **If the complete loader circuit fires or the engine does not flame out after the electric lock is turned off, or other accidents occur, please turn off the power switch immediately!**
3. **Before connecting the battery wire or retightening its connector, or removing the battery wire, please always turn off this switch for the sake of safety!**
4. **Before welding the complete loader, please always turn off this switch.**

323 Starting Switch

This power switch has three pins B, B1 and 3.

For the function gears of starting switch, see the table below:

Pin Position \	B	B1	3
OFF	○		
ON	○ — ○		
START	○ — ○ — ○		

Method to determine the starting switch for damage: Disconnect the #121, #28, #60 and #92 conductors from the starting switch, remove the starting switch from the loader, and set the digital multimeter to 200Ω resistance to check the switch as per the function gears (When the switch is in ON, pin B and pin B1; When the switch is in START, pin B and pin B1, pin B1 and pin 3). If the connection is normal, the switch works well; otherwise, the switch is faulty, and it should be repaired or replaced.

324 AC Generator

The generator, connected to storage battery in parallel, is a supporting element for the diesel engine and powers on the electrical devices of the complete loader. Before the wheel loader gets started, the power is supplied by the battery; after starting, the power will be supplied by the generator which charges the storage battery in the same time.



B+: Generator positive, connected to battery positive;
 D+: Charging indicator signal;
 W: Tachometer signal.

Fig. 3-7 Generator

Working principle of generator

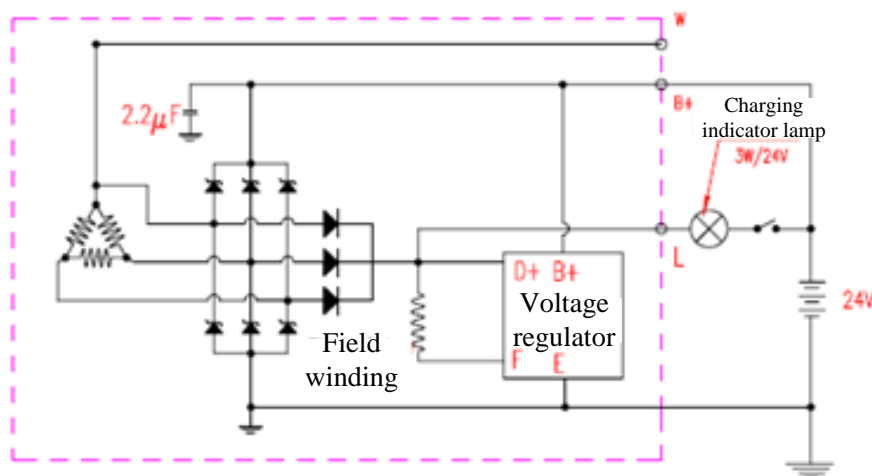

Fig. 3-8 Working principle of generator

The generator consists of rotor, stator, belt pulley, fan, front/rear end cover and electric brush etc. The excitation winding is generally wound around the rotor, the stator is connected in Y shape, and the rectifier is generally a six pipe bridge type full wave rectifier.

1. When the DCV is applied to both ends of the excitation winding, the current will generate a magnetic field. Driven by the generator, the magnetic field will rotate as with the rotor. Due to the effect of rotating magnetic field on the stator three-phase symmetrical windings, a simple sinusoidal electromotive force with the same three-phase frequency and amplitude, and 120° included phase difference will generate.
2. The unilateral conductivity of silicon diode can be applied to rectify. At any moment, only the positive diode connected to the one-phase winding with the highest electric potential is electrified; similarly, only the negative diode connected to the one-phase winding with the lowest electric potential is electrified; repeat this cycle all over again, and the six diodes will be electrified in turn, thus a stable pulsating DC voltage can be obtained on both ends of the load.
3. The generator terminal voltage is proportional to the generator speed: The variation range of engine speed is wide, therefore, the terminal voltage will vary greatly too, and the requirements for a constant voltage on electrical device of wheel loader will fail to be met. As a result, a voltage regulator should always be set.
4. The voltage regulator controls the connection and disconnection of switch tube to change the excitation current, which directly acts on the field's strength to stabilize the generator voltage.
5. The filter capacitor is mainly used to filter out the spike pulse and high-frequency interference sent out by the generator.

Method to determine the generator for normal generation and troubleshooting

1. Set the multimeter to 200V DCV to do inspection.

Turn on the electric lock, measure the generator terminal voltage (with red probe connected to generator D+, and black probe to ground), and record the reading of multimeter (this reading is actually the battery terminal voltage, and generally below 26V); start the loader, measure the generator terminal voltage again, and record the reading of multimeter (if the generator works normally, the reading should be approximately 28V).

2. Troubleshooting

If the generator fails to generate electricity or the generating voltage is too low: firstly, check the generator drive belt for looseness. Turn off the electric lock, and use a wrench to check the generator terminal for correct, secure and reliable connection. Moreover, check the generator ground for reliability at regular interval.

Common fault diagnosis to generator and troubleshooting

1. Generator fails to charge

The main causes include generator fault, regulator fault or electrical circuit fault etc. Remove the wire connection from the generator field terminals, turn on the electric lock switch, and use the multimeter (DC test lamp) to check the terminal. If there is electricity, the generator may be faulty. Do further check to the components such as generator electric brush, slip ring, rotor and stator or replace the generator. If there is no electricity, check the regulator field terminal. If the terminal is electrified, the wire connecting the regulator and the generator can be open circuited; if the terminal is not electrified, check the regulator live wire terminal. If the terminal is electrified, the regulator may be faulty, and check or replace the regulator; if the terminal is not electrified, the electric lock and the wire connecting the electric lock and the regulator can be open circuited etc.

2. Too low charging voltage

When the engine is working, the charging indicator lamp flashes or the ammeter swings around the zero, the starter runs weakly and even fails to drive the engine to run. The possible cause can be the unusual or faulty regulator operating voltage, too loose belt, generator inside fault or battery fault.

First of all, set the multimeter to DCV to measure the voltage at both ends of the battery or generator. If it is lower than the standard value, it shows the charging voltage is too low. Then, check the fan belt for slippage due to loose tension. If too loose, readjust as required. If it is normal, go on checking the generator and battery for fault. Method: Disconnect the battery ground wire when the engine runs at a moderate or above speed; if the engine runs normally, it indicates that the generator output power can meet the requirements of the ignition system and the powered devices, and that the battery has faults; if the engine flames out, it indicates that both the battery and generator has fault.

3. Too high charging voltage

If the generator voltage is too high, the bulb is easy to be burned out when the engine runs, and the water consumption in battery electrolyte can be too quick which may result from the unusual or faulty regulator operating voltage.

Start the generator and run it at a moderate speed, set the multimeter to DCV (25V) with the red probe connected to the generator armature terminal post and the black probe to the generator housing, and measure the voltage on both ends of the battery or the generator. If it is higher than the standard value, then the charging voltage is too high. In this case, a new electronic regulator should be replaced.

325 Starter Motor

The starter motor is a supporting element for the diesel engine and mainly consists of magnetic switch, DC motor, shifter fork and driving gear. The DC motor can convert the battery's electric energy to mechanical energy and the driving gear can drive the engine flywheel, thus realizing the engine start.

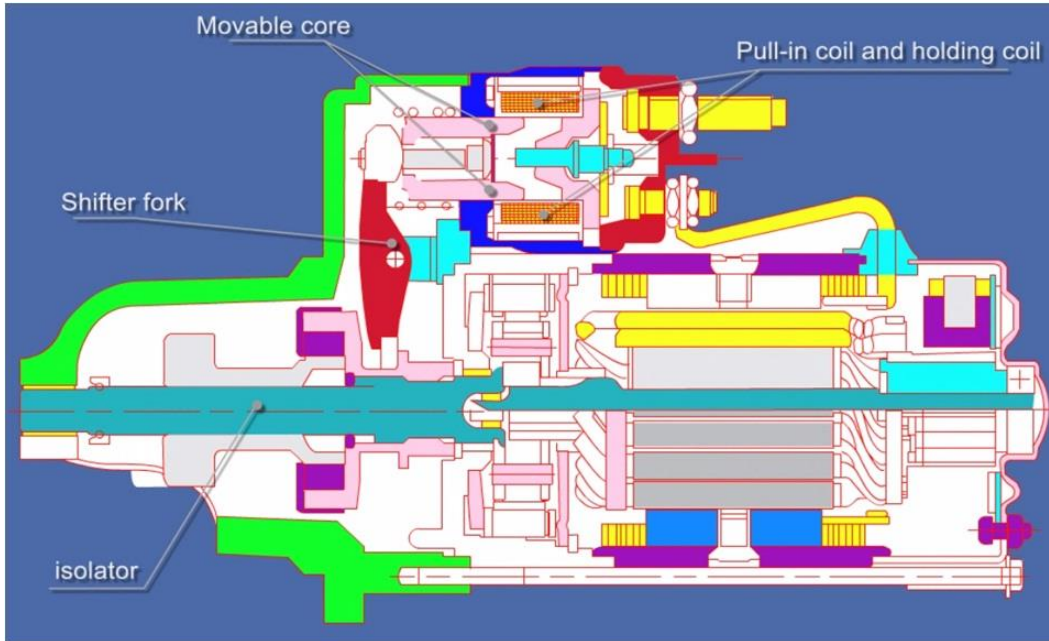

Fig. 3-9 Starter motor

When the complete loader gets started (the electric lock is turned to START), the 24V terminal voltage for the battery will pass through the starting relay contact to the starter motor, then the pull-in coil and holding coil will be connected to drive the pinion gear engaging with the flywheel gear. At this time, the current of pull-in coil passing through the excitation winding and the armature winding will generate certain electromagnetic torque, thus, the pinion gear, during its slow rotation, will engage with the ring gear.

After the engagement, the contact disc will trigger the two main contact terminals of motor to be connected and the battery strong current will pass through the armature winding and excitation winding of the starter, then normal torque will be generated to drive the crankshaft rotating, making the engine get started.

After the engine gets started successfully, at the moment the driver releases the key of electric lock, the current of holding coil and pull-in coil will flow in an opposite direction, therefore, the corresponding two magnetic fields will be in opposite directions. In this case, the electromagnetic forces acting on the core will offset each other, the core under the influence of spring force will reset to the original position, the drive pinion will exit from disengagement, and the contact disc will disconnect, consequently the starter motor will stop running.

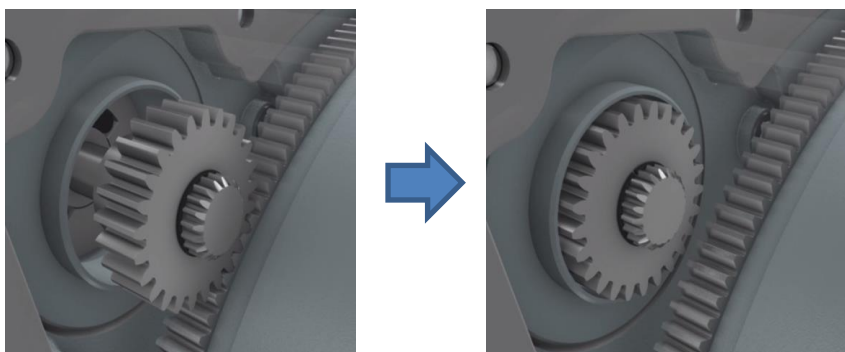

Fig. 3-10

Use and maintenance of starter motor

The operator does not have to do too much maintenance to the starter motor. However, if the basic maintenance cannot be met, the operator may encounter great trouble.

Precautions:

1. The voltage drop of starter motor positive or negative cable from any cause can degrade the starting performance, thus resulting in hard start and even start failure. Therefore, first of all, keep all the terminal posts in the battery circuit clean, and connect them firmly to reduce the contact resistance; secondly, check whether the engine housing and battery negative ground are in good conditions because most of the starter motor housing are grounded; thirdly, the section area of the cable and the materials in battery circuit should meet the requirements, and the cable overall length should be as short as possible to reduce the conductor resistance.
2. The starter motor sealing elements such as dust cover and gasket should be installed properly in case that the transmission lubricating oil and dust enters into the starter motor.
3. After the engine starts, the starter motor should stop running immediately to reduce wear and battery electric energy consumption caused by the unnecessary running of starter motor. Moreover, if the starter motor keeps running for too long, the temperature of the inside DC motor winding can increase too high and make the motor get burned out, meanwhile, the battery can subject to over-discharge, thus affecting the battery life span. In general, each start should not exceed 5s. If the engine cannot get started at a time, stop for 15s and then try to start again. If the engine fails to start for 3 successive times, find out the cause, eliminate the fault and then restart.
4. Before the start, turn off all the electrical devices irrelevant to the starting, meanwhile, engage the wheel loader to N to increase the starting ability of the starter motor and decrease the engine's drag torque.
5. If hard starting is caused by too low ambient temperature, warm up the engine fully before the start to reduce the viscosity of the engine lubricating oil and decrease the engine's drag torque.

Common fault diagnosis to starter motor

1) **Symptom:** Turn on the negative switch, and the starter motor runs itself.

Cause analysis: This fault generally results from contact point burnout for starting relay, electric lock or magnetic switch.

Troubleshooting: Grind the contact point and the moving contact disc again, or replace the magnetic switch or the starter motor.

2) **Symptom:** During the start, the starter motor does not have any reaction.

Troubleshooting:

1. Check whether the transmission control lever is turned to neutral position.

LG936L wheel loader has starting interlock function, and it will not get started unless the transmission neutral switch detects a signal.

2. While turning the electric lock to START, detect the conductor voltage at the magnetic switch of starter motor. If there is no voltage, check the electric lock, starting interlock relay and battery etc. Check the storage battery connection, negative switch and ground wire for reliable connection. Otherwise, it can be concluded that the start failure is caused by the fault inside the starter motor.

Starter fails to work

If the starter cannot work after it is powered on, the starting relay and starting switch may be turned off, or the connecting wire is open-circuited; if the starter still cannot work after the above-mentioned fault is eliminated, then the starter motor may have internal faults. In this case, the possible causes can be the fault in the magnetic coil of the starter magnetic switch, the motor switch ablation, poor contact, and motor electric brush, inverter, armature and magnetic field open circuit.

Starter underpower

The starter can drive the engine crankshaft to rotate, however, the running speed is too low and the engine cannot start smoothly, indicating the decrease of loading capacity and the actual output power. The possible causes can be battery feeding, looseness of battery connection terminal, poor contact caused by oxidation corrosion, motor switch ablation, inverter ablation, too much wear of electric brush or lack of spring, and local short circuit in motor armature and field winding; and too large starting drag torque caused by too tight engine assembly or too low ambient temperature.

Starter couldn't stop

If the starter cannot stop working after the power starting switch is released, the possible causes can be the power starting switch fault, starting relay fault or motor switch bonding.

Starter idling

If the starter runs but the engine crankshaft cannot rotate, the possible causes can be the one-way clutch slippage, fork mechanism malfunction or seizure, insufficient push-out by driving gear, too much gear teeth collision or wear, and fork shaft loss etc. The fault can be eliminated as long as the clutch is replaced.

Too large starting noise

If rhythmic crash is produced during the start, the possible causes can be the open circuit in magnetic switch holding coil, starting relay damage, battery electricity shortage or poor pole contact etc.; if the friction or whistling is constant, the possible causes can be motor sweep chamber caused by bearing wear, armature shaft bend and rotor out-of-round, or inverter ablation and electric brush poor contact etc.

33 Instrument Monitoring System

331 Instrument Panel

Gauges and switches

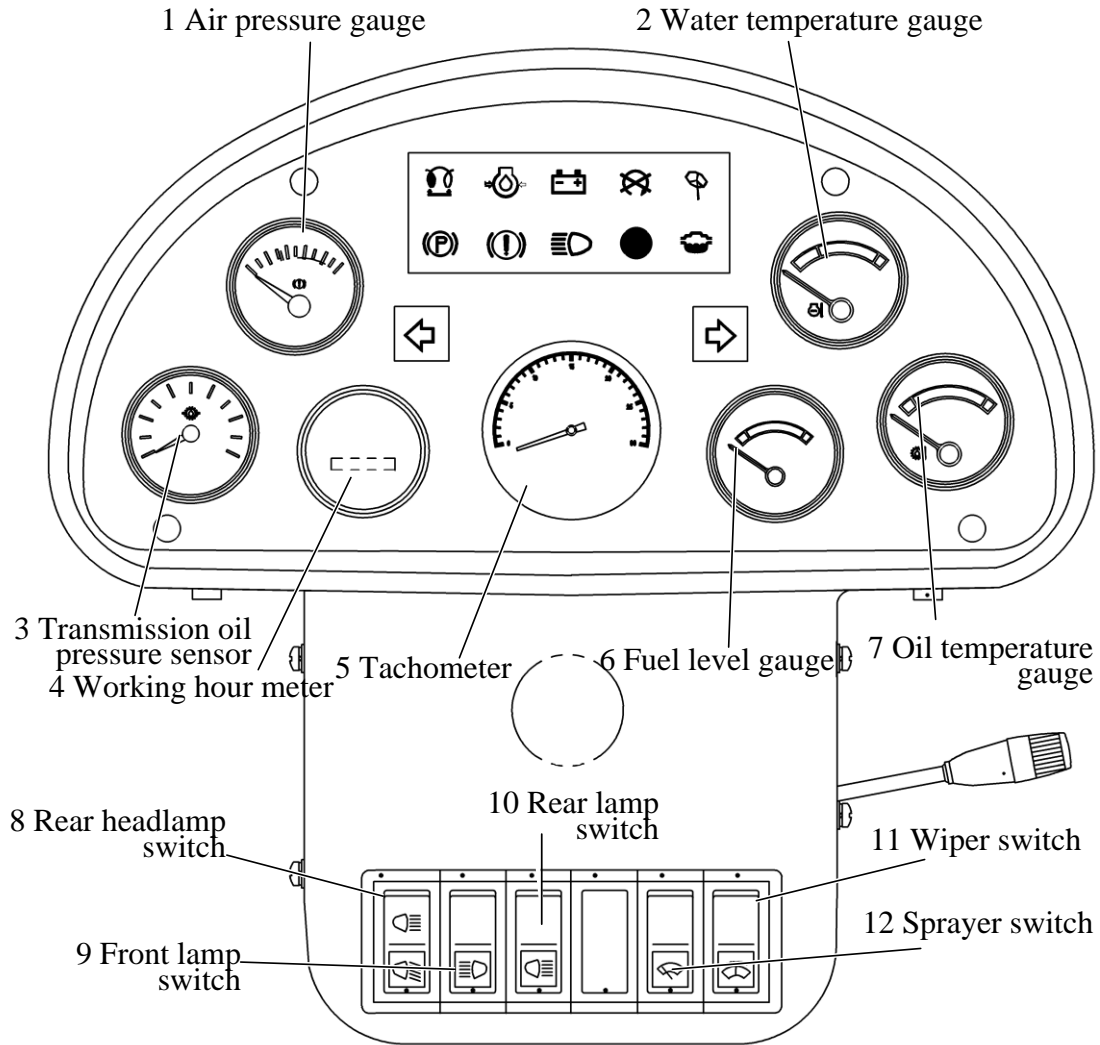

Fig. 3-11 Instrument panel

S/N	Name	Range	Green range
1	Air pressure gauge	0~10bar	——
2	Water temperature gauge	40~115°C	60~100°C
3	Transmission oil pressure gauge	0~25bar	——
4	Working hour meter	0~9999.9h	——
5	Tachometer	0~3000rpm	——
6	Fuel level gauge	0~1	——
7	Oil temperature gauge	60~140°C	60~120°C

Alarm and indicator lamps

Left steering indicator	Charging indicator	Coarse filter indicator	Low brake air pressure alarm indicator	Control unit working indicator	High beam indicator
Green	Red	Red	Red	Red	Blue
Parking brake indicator	Low engine oil pressure alarm indicator	Emergency steering indicator	Preheat indicator	Power cut-off indicator	Right steering indicator
Red	Red	Red	Red	Red	Green

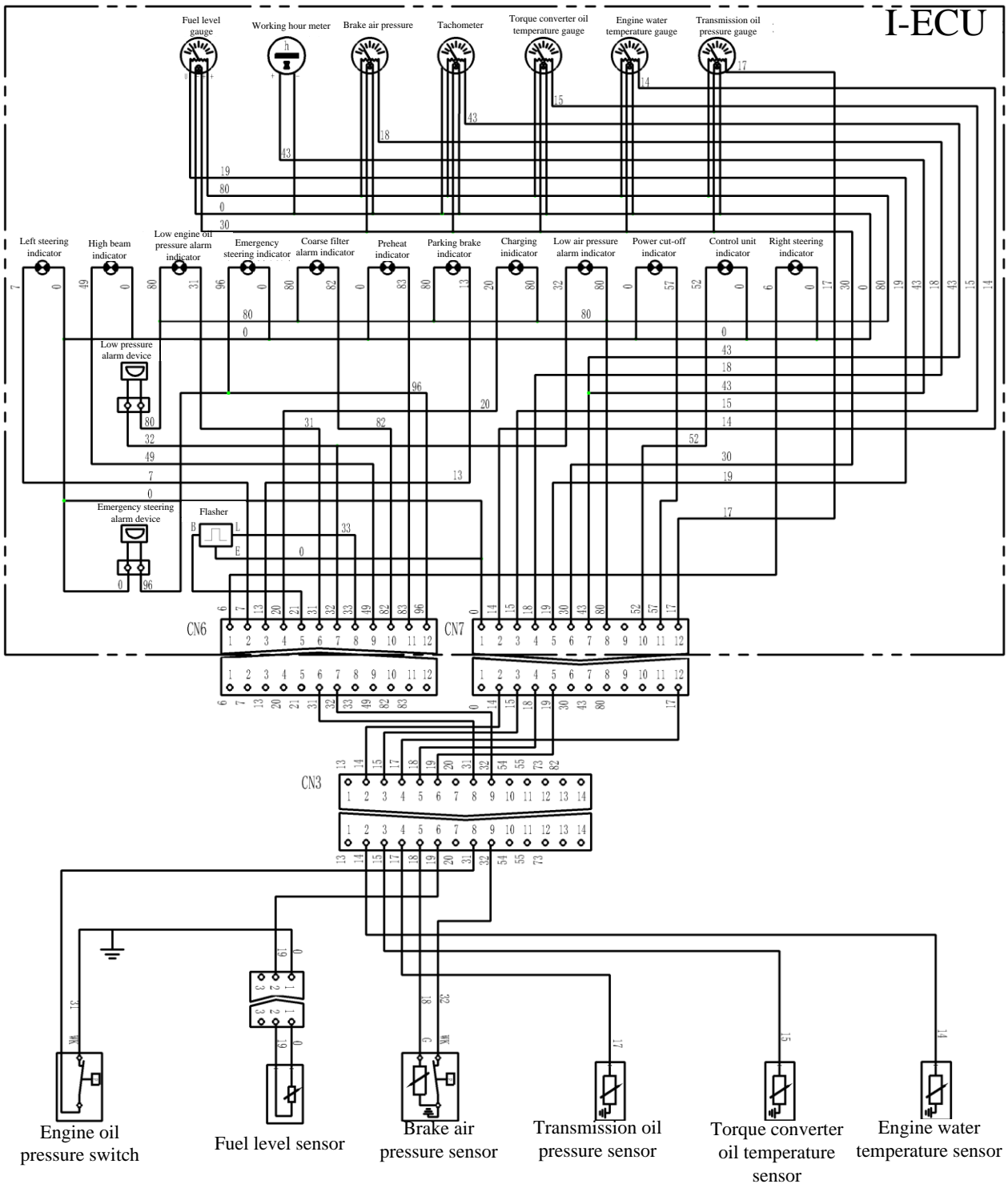

Fig. 3-12 Instrument monitoring system

332 Sensors

Temperature sensor (Engine water temperature)

LG936L is equipped with temperature sensors to monitor the engine water temperature. The temperature sensor is a thermistor whose resistance will decrease if the temperature rises.

Overhaul when thermometer indication is abnormal:

Remove the sensing line (engine water temperature corresponds to #14 conductor) from the temperature sensor. If the instrument displays full range when the sensing line is grounded, or it displays the min. reading when the sensing line is suspended, then it shows that the instrument and wires are in good conditions but the sensor is damaged. Replace the sensor. Otherwise, check the wires. If the wires are in good conditions, the instrument may be faulty.

Pressure switch (Engine oil pressure)

The pressure switch is a simple pressure control device. When the tested pressure reaches the rated value, the pressure switch can trigger the alarm or transmit control signal.

Working principle: When the tested pressure exceeds the rated value, displacement will occur to the free end of the flexible components. Push the switch directly or after the comparison to change the on-off state of the switch so as to control the tested pressure. The complete wheel loader is equipped with two pressure switches (i.e. low brake pressure alarm switch and low oil pressure alarm switch); when the brake pressure is lower than 0.45MPa or the engine oil pressure is lower than 0.08MPa, the alarm indicator will be and buzzer will sound.

Fuel level sensor

The fuel level sensor is actually a discrete slide resistance. As with the increase of fuel level, the resistance will decrease. The sensor is installed to the fuel tank.

Troubleshoot abnormal indication of fuel level indicator:

Remove the sensing line (#19 conductor) from the fuel level sensor. If the instrument displays full range when the sensing line is grounded, or it displays the min. reading when the sensing line is suspended, then, it shows that the instrument and wires are in good conditions but the sensor is damaged. Replace the sensor. Otherwise, check the wires. If the wires are in good conditions, the instrument itself may be faulty.

34 Lighting System

341 Front Combination Lamp Circuit

Turn on the electric lock, the 10A front headlamp fuse in fuse block (path 20) will be electrified (24V), and the current will flow to the rocker switch via #44 conductor and meanwhile to the contact points of front combination lamp high/low beam relay via #35 conductor. When the combination switch is turned off, #49 and #50 conductors will not be electrified, and front and rear headlamps will not work; when the switch is turned on, #49 or #50 conductors will be electrified (24V), and the coils of front combination lamp high/low beam relay will also be electrified; to close the contact point, the front headlamps (high beam or low beam) will be electrified (24V) and they will work in corresponding positions at the same time.

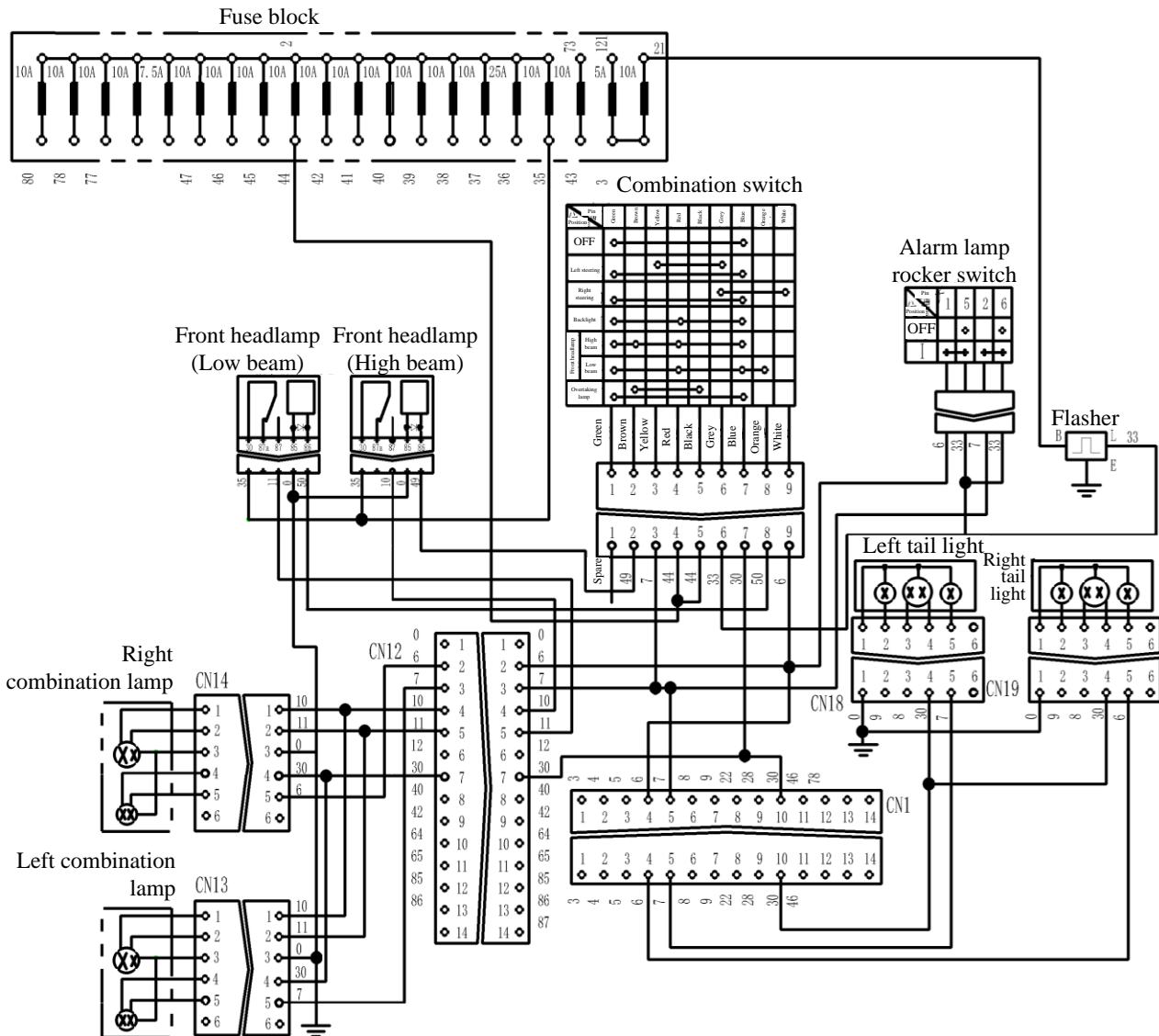

Fig. 3-13 Circuit diagram of front combination lamp, alarm lamps and steering lamps

Common troubleshooting to front combination lamp

1. Check the bulb for blackening. If it turns black, the bulb may be damaged, and it should be replaced.
2. Remove the connector, set the dimmer switch respectively to high beam and low beam positions, and use the multimeter DCV to detect the voltage of #49 and #50 conductors at the connector. If the voltage is 24V, check the connector for reliable connection. In case of loose connection, connect them again. Otherwise, the internal wiring of front combination lamp may get loosened or the bulb may be damaged. If the voltage is 0V, check as the steps below.
3. Check the 10A front headlamp fuse for blowout.
4. Check the connector for reliable connection and wiring harness for wear.
5. Check the combination switch.

342 Front Lamp Circuit

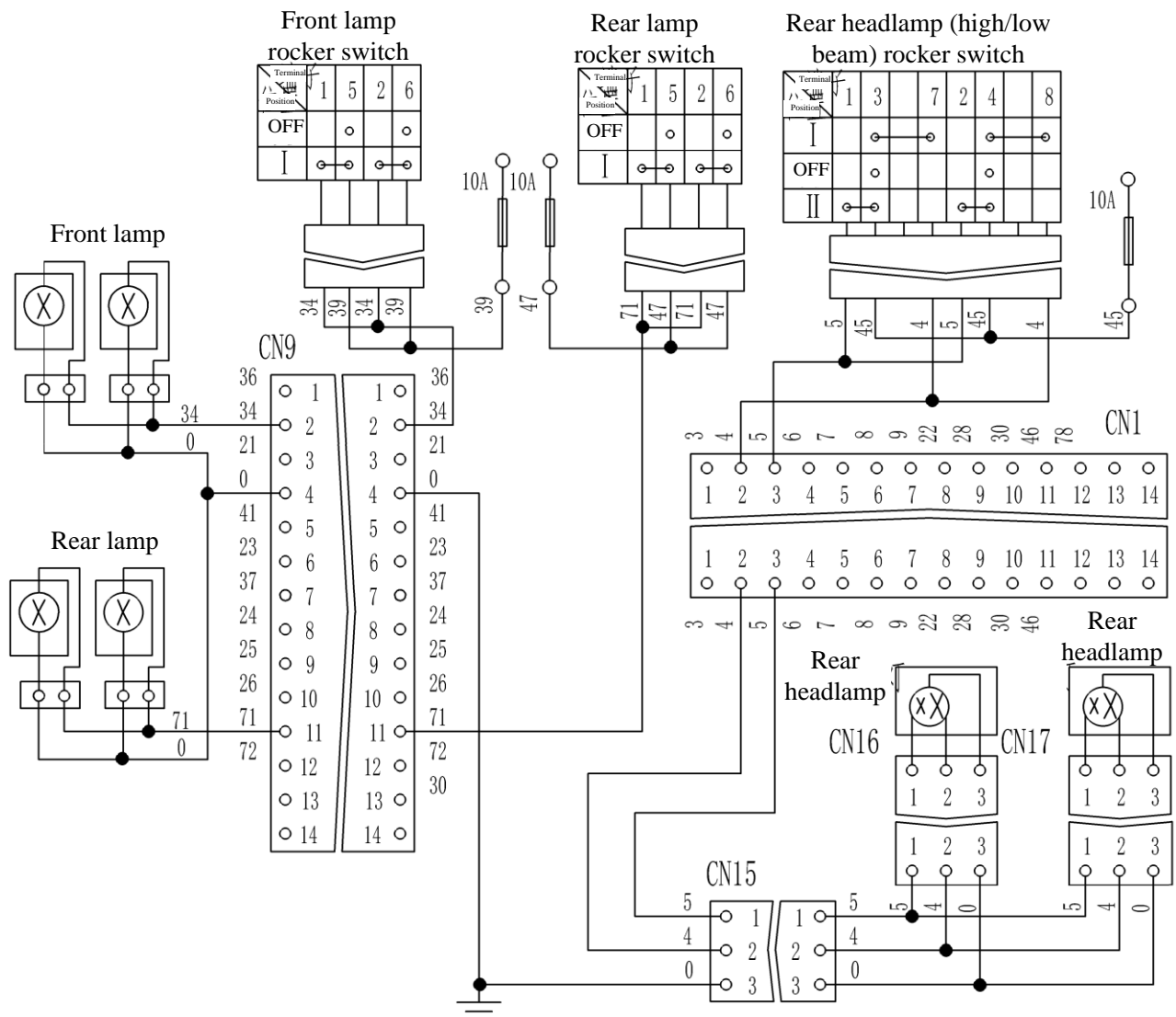

Fig. 3-14 Circuit diagram of front and rear headlamp

Turn on the electric lock, the 10A front lamp fuse in fuse block (path 20) will be electrified (24V), and the current will flow to rear headlamp high/low beam rocker switch via #45 conductor and meanwhile flow to rear lamp rocker switch and front lamp rocker switch via #47 and #39 conductor. When rear headlamp high/low beam rocker switch is in off state, #5 and #4 conductors are not electrified and rear headlamp doesn't work. When rear headlamp high/low beam rocker switch is turned on, #4 or #5 conductors will be electrified (24V), and rear headlamp will be on in high/low beam form. When front and rear lamp rocker switch is off, #34 and #71 conductors are not electrified and front and rear lamps don't work. When front and rear lamp rocker switch is turned on, #34 and #71 conductors will be electrified (24V), and front and rear lamps will be on.

35 Reverse Alarm System & Electric Horn System

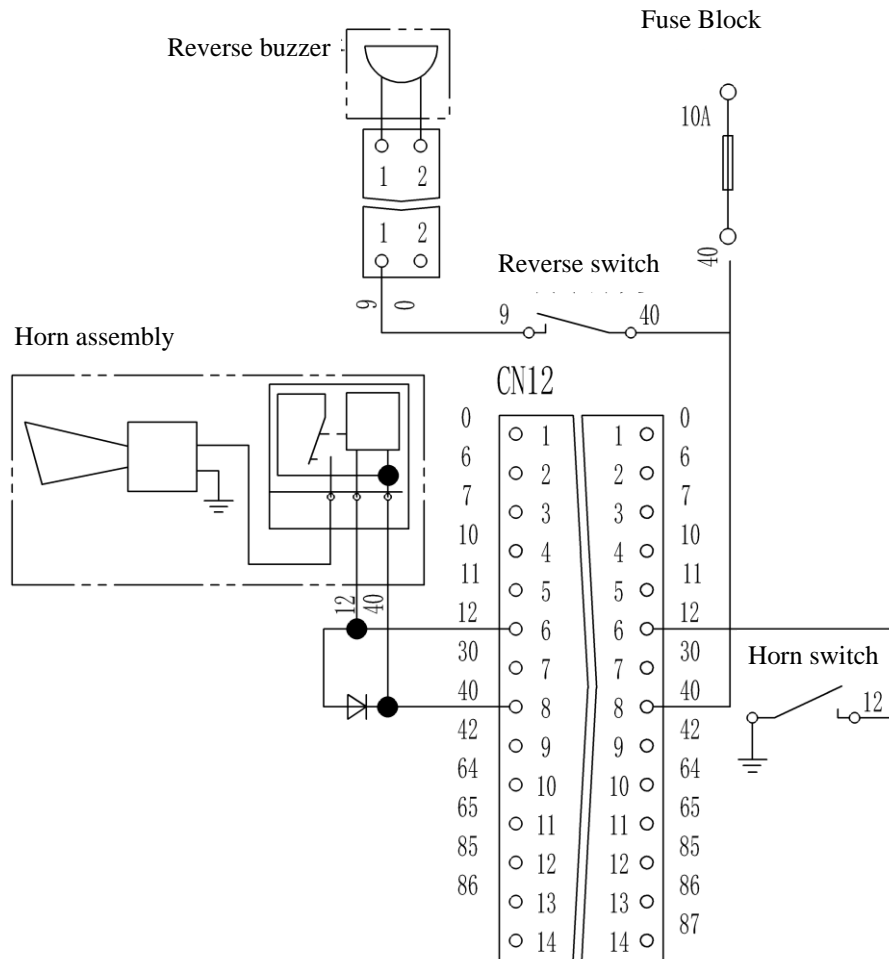

Fig. 3-15 Reverse alarm system & Electric horn system

351 Reverse Alarm System

Turn on the electric lock, and 10A reversing warning fuse (#40 conductor) will be electrified (24V). Engage to a reverse gear, the reverse switch will be turned on, #9 conductor will be electrified, and the buzzer will ring.

Common faults analysis

Turn on the electric lock and engage a reverse gear, if the reverse alarm does not buzz:

1. Check the 10A reverse alarm fuse for blowout.
2. Check the connector and conductor for firm and reliable connection. #9 conductor open circuit

in the middle generally results from connector looseness or wiring harness wear.

3. Check the reverse switch for damage. If it is in good condition, engage the switch to REVERSE, and the two corresponding conductors will be connected.
4. If the above-mentioned problems do not occur, please check the voltage of #9 conductor at the reverse alarm. If the voltage is normal (24V), the alarm can be damaged and it should be replaced; if there is no voltage, the connector may get loosened or wiring harness may be worn in general.

Turn on the electric lock, the buzzer keeps buzzing regardless of the gears; such events generally result from the adhesion of reverse switch contact, and they are, in rare occasions, caused by #9 conductor and certain power wire short circuit.

352 Electric Horn System

Turn on the electric lock, the 10A electric horn fuse will be electrified (24V); press down the electric horn switch, the current will pass through 10A electric horn fuse – electric horn – electric horn switch – ground, and the electric horn will keep buzzing, release the switch and the buzzing will stop.

Common faults troubleshooting

Turn on the electric lock and press down the electric horn switch, but the electric horn fails to alarm:

1. Check the 10A electric horn fuse for blowout.
2. Check whether the electric horn switch (button in the middle of steering wheel) works normally. Under normal condition, when the electric horn switch is pressed down, #12 wire will be grounded.
3. Check the connector for looseness and wiring harness for wear.
4. Check the electric horn for damage (Connect the two terminal posts of electric horn to the 24V power and the ground respectively. If the electric horn does not sound, it can be concluded that the electric horn is damaged).

36 Wiper and Cleaning System

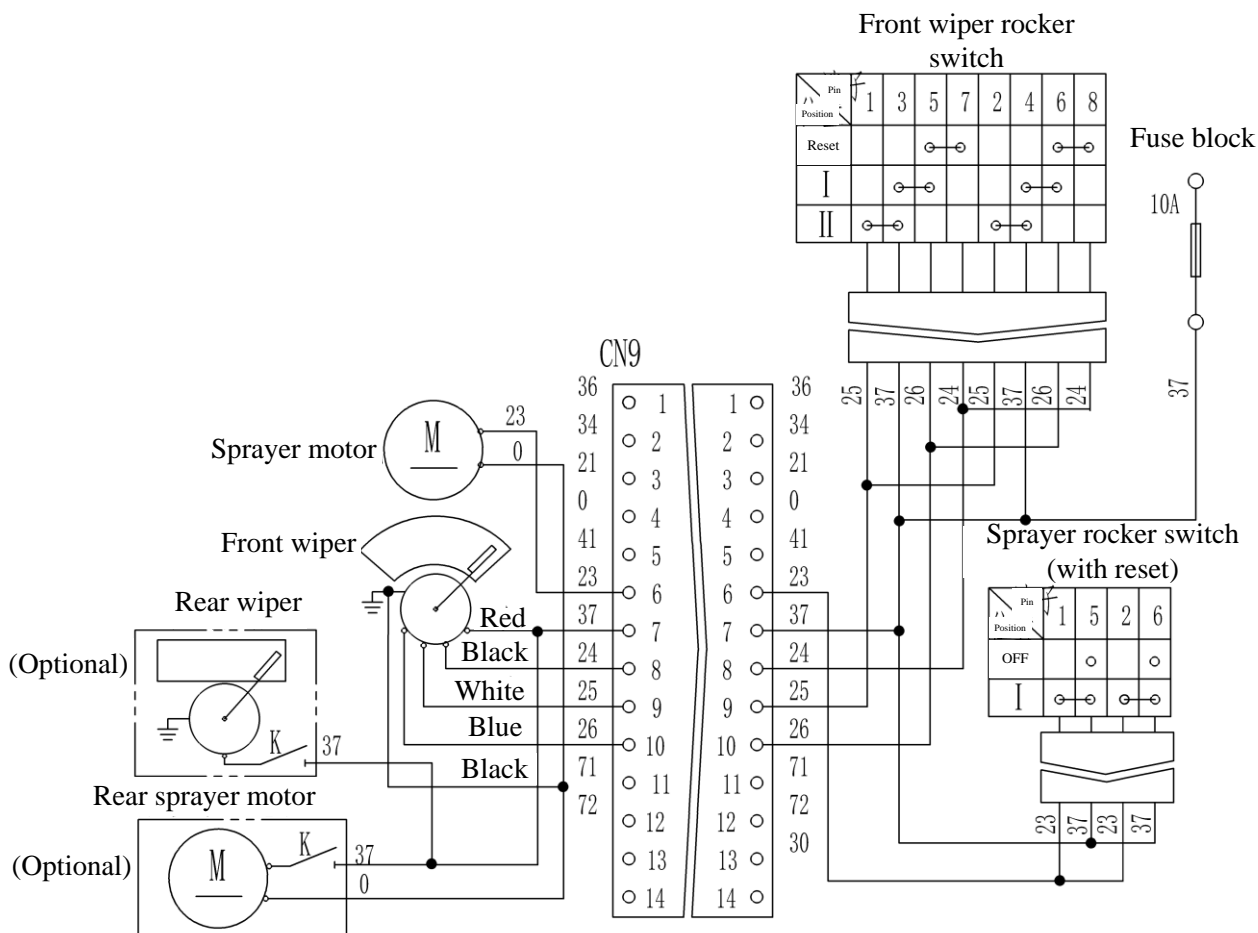

Fig. 3-16 Wiper and cleaning system

Working principle of cleaner

Turn on the electric lock, the 10A wiper fuse will be electrified (24V), the spray switch (i.e. auto reset rocker switch) will be turned on, and the injection motor (installed to the water reservoir) will be electrified to work by #37 conductor, then the water in the reservoir can be pumped to the nozzle (installed below the cab windshield) and sprayed to the windshield.

Working principle of wiper

The wiper motor is a permanent magnet motor. It controls the positive, after the electric lock is turned on, #37 conductor will be electrified (24V).

The five conductors outside the wiper motor are as shown:

Red: Power wire;

Black: Reset wire, connected to the ground at the original position;

Blue: The other electric brush lead for high gear armature;

White: The other armature brush lead for low gear armature;

Gear I: Low speed gear, pin 37 connected to pin 25;

Gear II: High speed gear, pin 37 connected to pin 26;

OFF: Pin 24 is connected to pin 25 to ensure that the wiper can always stay in the original position.

Common faults troubleshooting

Wiper motor fails to work

1. Check the 10A wiper fuse for blowout.
2. Check the wiper switch for damage.
3. Check the connector for looseness and wiring harness for wear.
4. Check the armature of wiper motor for short circuit or open circuit.

Nozzle fails to spray water out

1. Observe whether the motor is running and pumping water.
2. Check the waterway for disconnection (water pipe breaks or is over-tightened).
3. Check the nozzle for blockage.

37 Wiring Harness Routing

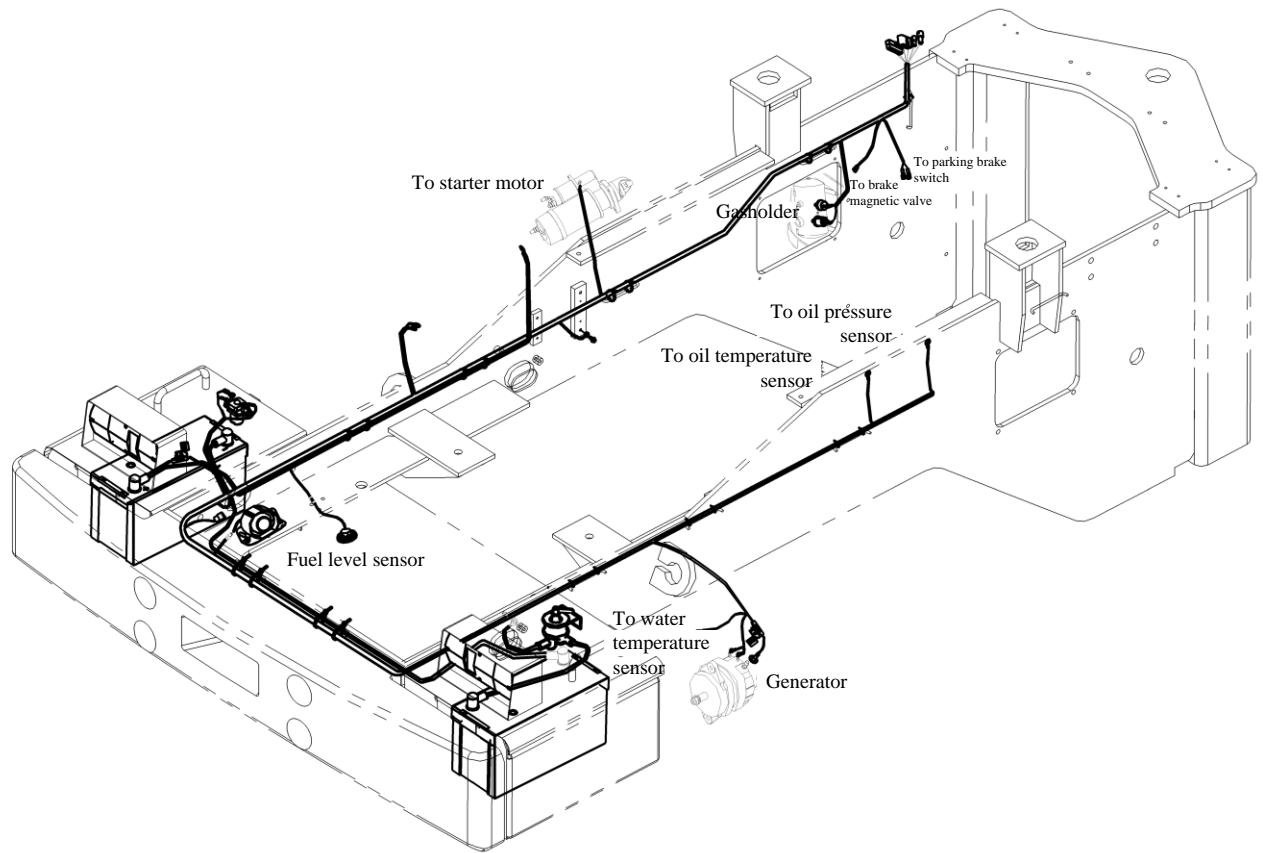

Fig. 3-17 Sketch map for rear frame wiring harness routing

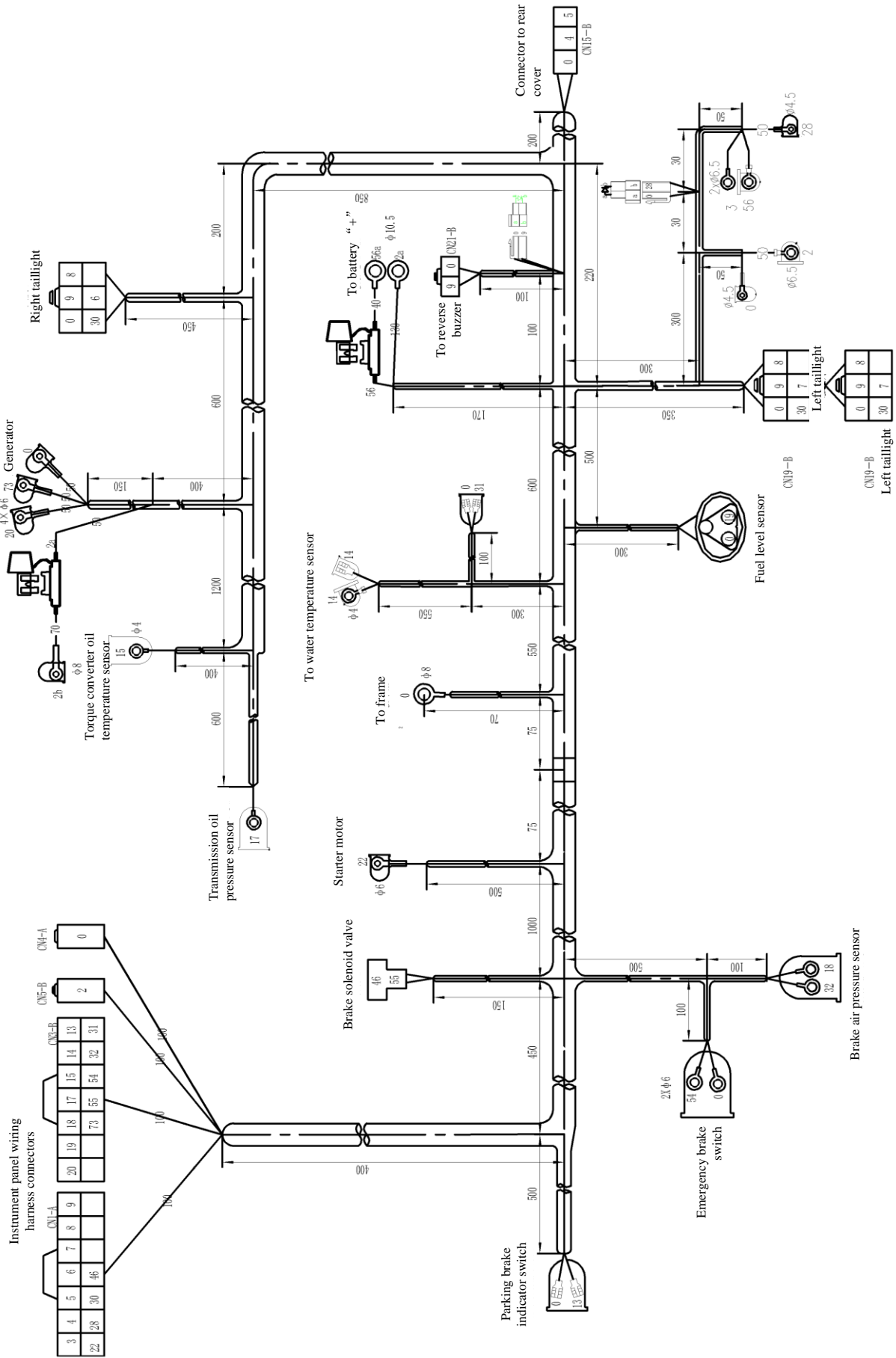

Fig. 3-18 Rear frame wiring harness

Wire No.	Name	Sectional area (mm ²)	Color
0	Ground wire	5	Black
2a/2b	Generator charging wire	5	Yellow
2	Wire between battery and fuse block	5	Red
3	Power wire of the whole machine	2	Green
4	Rear headlamp high beam wire	1.25	White
5	Rear headlamp low beam wire	1.25	Red
6	Right steering lamp wire	0.85	Yellow
7	Left steering lamp wire	0.85	Blue
8	Brake switch wiring	0.85	White
9	Reverse buzzer & reverse lamp wiring	0.85	Green
10	Front headlamp high beam wire	1.25	Purple
11	Front headlamp low beam wire	1.25	Orange
12	Horn button wire	0.85	White
13	Parking brake indicator lamp wiring	0.85	Grey
14	Engine water temperature sensor wire	0.85	Brown
15	Torque converter oil temperature sensor wire	0.85	Yellow
17	Signal wire of transmission oil pressure gauge	0.85	Blue
18	Brake pressure sensor wire	0.85	Brown
19	Fuel level sensor wire	0.85	Red
20	Charging indicator alarm lamp wire	0.85	Purple
22	Electric lock to starting relay and oil cut-off valve relay wiring	0.85	Green
28	Battery relay coil positive wire	0.85	Red
29	Oil cut-off valve relay to oil cut-off valve	0.85	White
30	Wire of width lamp and backlight	0.85	Red
31	Engine oil pressure alarm wire	0.85	White
32	Brake air pressure alarm signal wire	0.85	White
46	Power wire of brake magnetic valve	0.85	Purple
54	Connecting wire from emergency brake to parking brake switch	0.85	Orange
55	Wire from brake magnetic valve to parking brake switch	0.85	Green
56/56a	Battery relay positive wiring	5	Brown
73	Working hour meter wiring (generator end)	0.85	Grey

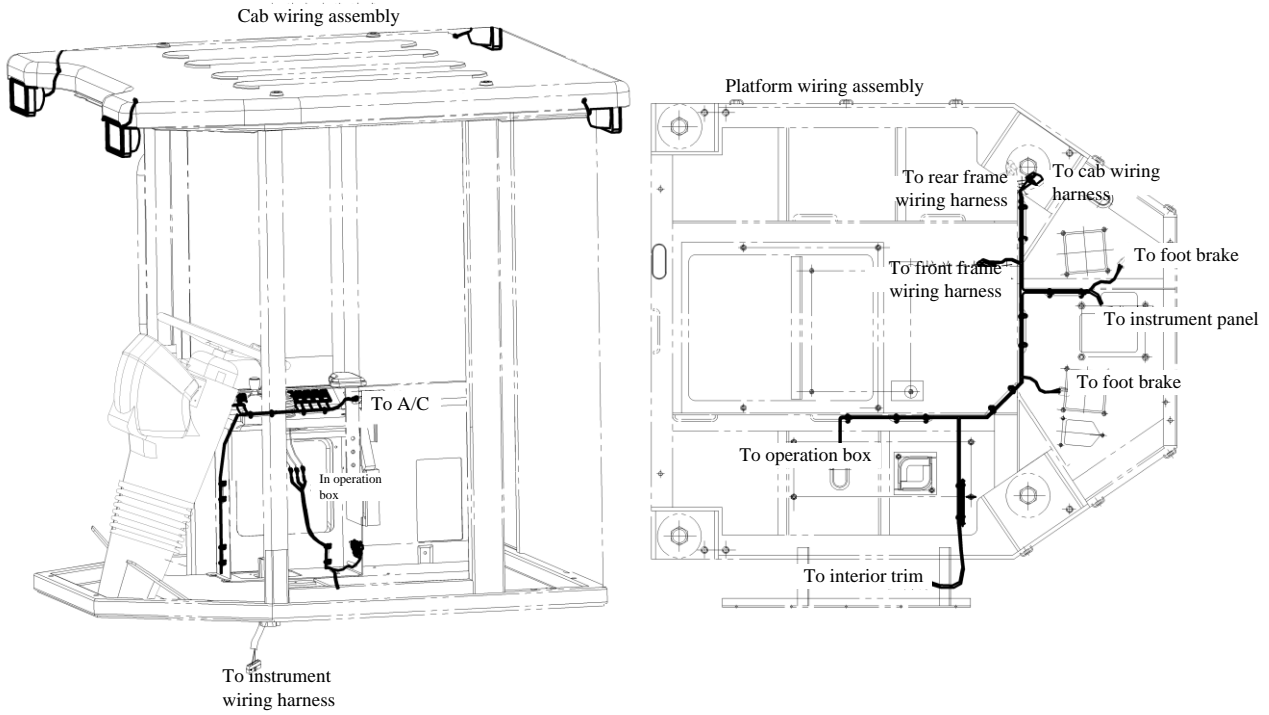

Fig. 3-19 Sketch map for cab wiring harness routing

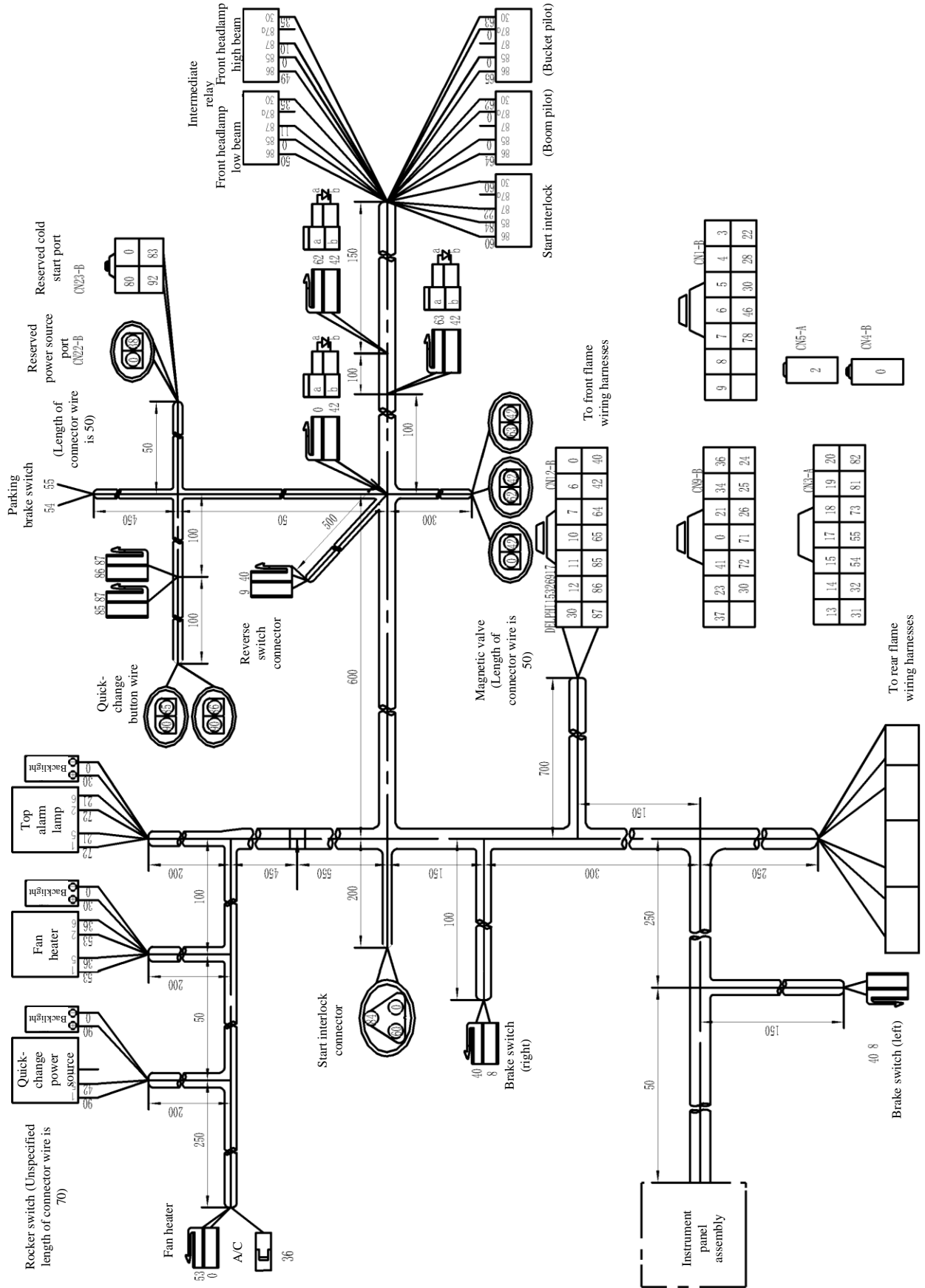
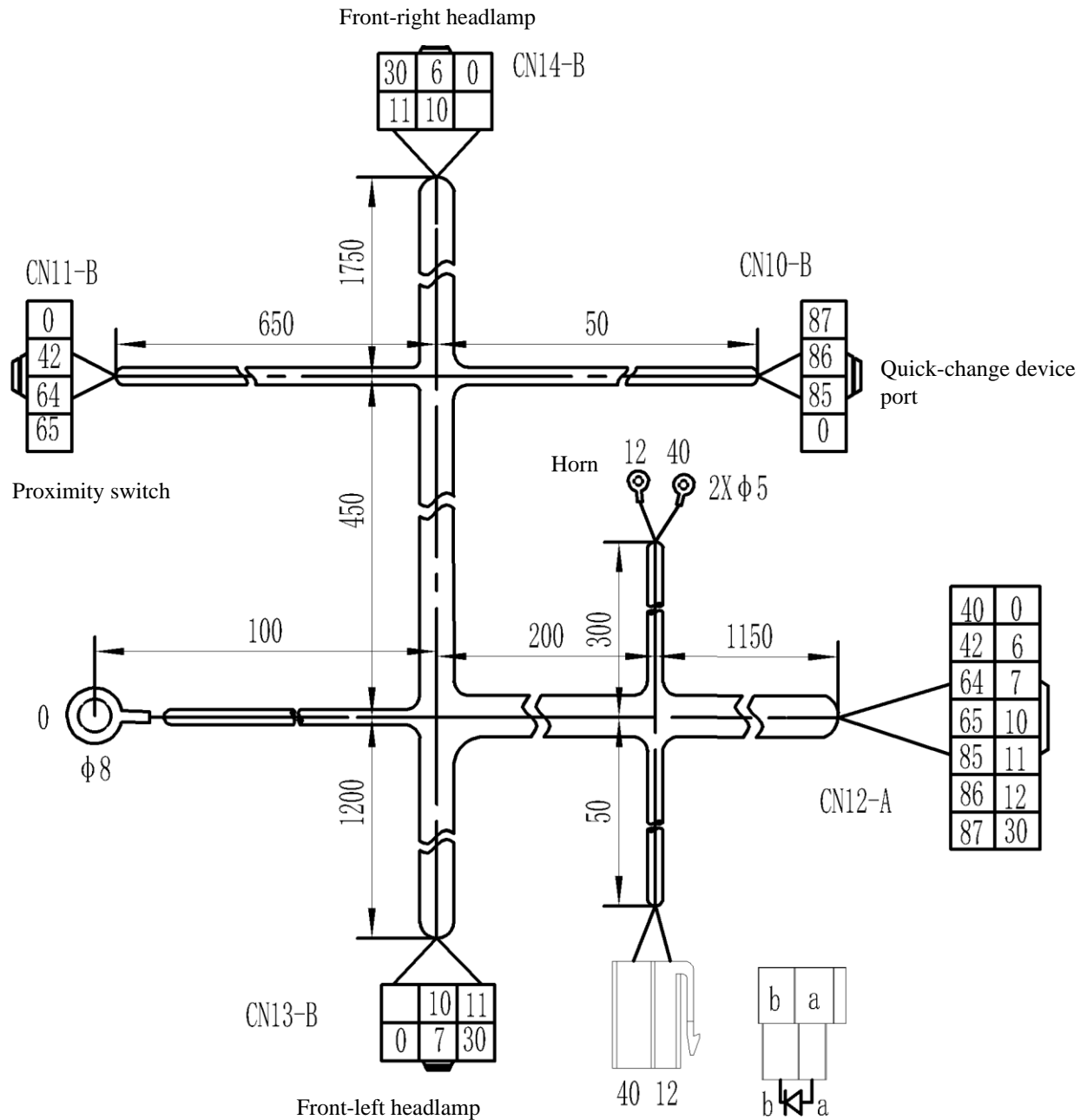

Fig. 3-20 Instrument panel wiring harness

Wire No.	Name	Sectional area (mm ²)	Color
0	Ground wire	5	Black
2	Wire between battery and fuse block	5	Red
3	Power wire of the whole machine	2	Yellow
4	Rear headlamp high beam wire	1.25	White
5	Rear headlamp low beam wire	1.25	Red
6	Right steering lamp wire	0.85	Yellow
7	Left steering lamp wire	0.85	Blue
8	Brake switch wiring	0.85	Red
9	Reverse signal wire	0.85	Green
10	Front headlamp high beam wire	1.25	Purple
11	Front headlamp low beam wire	1.25	Orange
12	Horn button wire	0.85	White
13	Parking brake indicator lamp wiring	0.85	Grey
14	Engine water temperature sensor wire	0.85	Brown
15	Torque converter oil temperature sensor wire	0.85	Yellow
17	Signal wire of transmission oil pressure gauge	0.85	Blue
18	Brake pressure sensor wire	0.85	Brown
19	Fuel level sensor wire	0.85	Red
20	Charging indicator alarm lamp wire	0.85	Purple
21	Fuse block upper wiring	2	Brown
22	Electric lock to start relay wiring	0.85	Red
23	Sprayer control wire	0.85	Purple
24	Wiper reset wire	1.25	Black
25	Wiper low speed wiring	1.25	White
26	Wiper high speed wiring	1.25	Blue
28	Battery relay coil wiring	1.25	Red
30	Wire of width lamp and backlight	1.25	Red
31	Engine oil pressure alarm wire	0.85	White
32	Brake air pressure alarm signal wire	0.85	White
33	Flasher signal wire	1.25	White
34	Front lamp wiring	1.25	Orange

35	Power wire of front headlamp and backlight	2	Red
36	A/C and heater power wire	3	Green
37	Wiper power wire	1.25	Red
38	Reserved cold start power wire	1.25	Blue
39	Front lamp power wire	1.25	Brown
40	Reverse/horn power wire	0.85	Green
41	Radio power wire	1.25	Brown
42	Power wire of pilot valve	1.25	Red
43	Working hour meter power wire	0.85	Grey
44	Combination switch power wire	1.25	Yellow
45	Rear headlamp power wire	1.25	Red
46	Brake magnetic valve power wire	0.85	Purple
47	Rear lamp switch power wire	1.25	Brown
49	Combination switch to intermediate relay wiring	0.85	Brown
50	Combination switch to intermediate relay wiring	0.85	Orange
53	Heater wiring	1.25	Red
54	Heater wiring	0.85	Orange
55	Brake magnetic valve to parking brake switch wiring	0.85	Green
60	Electric lock to starting interlock wiring	0.85	Grey
61	Preheat signal wire	0.85	Yellow
62	Intermediate relay to electromagnetic valve (boom) wiring	0.85	Grey
63	Intermediate relay to electromagnetic valve (bucket) wiring	0.85	Purple
64	Proximity switch (boom) signal wiring	0.85	Yellow
65	Proximity switch (bucket) signal wiring	0.85	Brown
71	Rear lamp wiring	1.25	Grey
72	Top alarm lamp wiring	0.85	Yellow
73	Generator W terminal signal wire	0.85	Grey
76	Power wire of power cut-off, reverse and start relay	0.85	White
77	Power wire of reserved socket	1.25	Yellow
78	Power wire of coarse filter	1.25	Red
80	Instrument panel power wire	1.25	Red
81	Speed sensor signal wire	0.85	Green

82	Coarse filter alarm signal wire	0.85	Yellow
83	Preheat signal wire	0.85	Green
84	Preheat signal wire	0.85	Black
85	Quick-change wire	0.85	Purple
86	Quick-change wire	0.85	Grey
87	Quick-change buzzer wire	0.85	Red
90	Power wire of quick-change button	0.85	Green
92	Power wire of preheat control box	1.25	Red
121	Power wire from fuse block upper end to electric lock	1.25	Red

Fig. 3-20 Front frame wiring harness

Wire No.	Name	Sectional area (mm ²)	Color
0	Ground wire	5	Black
6	Right steering lamp wire	0.85	Yellow
7	Left steering lamp wire	0.85	Blue
10	Front headlamp high beam wire	1.25	Purple
11	Front headlamp low beam wire	1.25	Orange
12	Horn button wire	0.85	White
30	Wire of width lamp and backlight	1.25	Red

40	Reverse/horn power wire	0.85	Green
42	Power wire of magnetic valve	1.25	Red
64	Proximity switch (boom) signal wiring	0.85	Yellow
65	Proximity switch (bucket) signal wiring	0.85	Brown
85	Quick-change wire	0.85	Purple
86	Quick-change wire	0.85	Grey
87	Quick-change buzzer wire	0.85	Red

38 Fault Inspection and Diagnosis

381 Basic Method to Fault Inspection and Diagnosis

Circuit analysis

The circuit analysis method is studying the circuits of various parts from part to whole gradually. To study a certain circuit, you should get familiar with its working principle, analyze and take grasp of the circuit depending on its nature of work and applying the relevant connecting principles.

For the specific method: you can search from the power to electrical devices along the flow direction of operating current or from the electrical devices to power against the flow direction of operating current. It is more convenient to search the unfamiliar circuits in the latter one.

The electrical diagram can be read and understood with the principle of breaking up the whole into parts and the principle of closed circuit. It is helpful to circuit troubleshooting if the conductor can be easily found out from two connected devices.

The electrical circuit diagram features the following:

1. The electrical devices for the wheel loader apply the single-wire system. While analyzing the circuit principle, search from the electrical device, along the circuit, through the circuit switch, protector etc. and to the power positive. To form a loop, the electrical devices have to be grounded, therefore, the faults caused by poor electrical element ground should not be ignored while searching for the fault.
2. There are two power supplies on the backhoe loader. In other words, the generator and the battery are connected in parallel with circuit protector set in between.
3. The electrical devices are connected in parallel and controlled by relevant switches via controlling the power wire and the ground wire.
4. The circuit protectors are installed in all electrical circuits to avoid circuit damage or electrical device damage caused by short circuit or ground.

Inspection of the electrical circuit condition

When doing technical maintenance to the wheel loader or the driver finds out any fault, check the appearance of the entire loader electrical circuit, mainly including:

1. Fixing: All electrical components and wires should be fixed reliably, and the housing and components should be in good conditions.
2. Connection and cleaning: The connectors should be connected firmly, the ground point should be firm, the contact point should be free from rust, oil stain and ablation, and the wire surface should be free from oil stain, dirt and dust.

3. Insulation and shielding: The wire insulating layer should be free from damage and aging, the exposed area should be covered by adhesive tape, and the wire shielding layer should be free from breakage and scratch.
4. Fuse and relay: The fuses and relays should be installed firmly, the wire connection should contact well, and the selected fuses and relays should be complete and meet the rated values of the circuit.
5. Switch operating condition: The switches and buttons should move smoothly without any stagnation or failure.

Instrument detection

Use the instrument or special detector to check the electrical circuits accurately to determine the faulty part and eliminate it. While the electrical elements are applied in the circuit, it is not allowed to apply clashing method to check the circuit. But the voltmeter and the DC lamp can be used.

1. Test voltage

The technical conditions for the starting and power system can be determined via measuring the voltage of the relevant parts. As one of the daily maintenance items for wheel loader, it is of great importance to the correct application of electrical system and the timely troubleshooting etc.

To measure the battery voltage, keep the headlamp on for about 30s, remove the floating electricity from the battery surface, and then turn off the headlamp.

Measure the voltage between the battery positive and negative, and it should be higher than 12.5V.

Measure the starting voltage to determine the battery, starter and connecting wire state. Turn the electric lock to START to run the engine, and the voltage on both ends of the battery should be higher than 9.5V within 15s. If it is lower than this value, the connector of the battery cable may be corroded or connected poorly; or the battery may be over discharged or faulty; or the starter motor may have fault.

2. Measure circuit voltage drop

The voltage drop test method can be used to test the conductors, battery cables and connectors. The circuit resistance can be measured by ohmmeter, however, the low voltage and the current cannot indicate actual condition. Therefore, it is more reasonable to determine the conductor and the contact point state by measuring the voltage drop when the normal current is through. Select a voltmeter with range of 0~3V and precision more than 1.0 grade, and shift the circuit to working state. In general, the circuit voltage drop is 0.1V, and that of the starting circuit should be no higher than 1V.

3. Test battery electricity leakage

The battery electricity leakage test can determine faults such as ground and insulation damage. Turn off all switches to electrical equipment and measure the current between the battery negative and the ground, which, in general, should not exceed 30mA. The current of the wheel loader with ECS should be no more than 300 mA. Otherwise, the battery leaks electricity. The possible causes can be electricity leakage from circuit switch/conductor or poor insulation; or short circuit in the generator diode or too large leakage current; or faulty regulator or ECU; or faulty switch.

4. Check open circuit and short circuit

Check open circuit: Use the test lamp or special tool to check for open circuit, connect the test lamp or special tool between the circuit connector and the ground. Turn on the corresponding switch, if the lamp is not on, there is open circuit.

Check short circuit: When a short circuit occurs, the fuse (fuse wire) can be burned out. The causes should be found out before the replacement of the fuse. The commonly used methods are as follow:

Method A: Ohmmeter: Connect one probe to ground point and the other to the fuse connection, and the short circuit occurs if the resistance is zero or very small. Disconnect the electrical devices controlled by the fuse one by one, if the resistance increases, short circuit occurs in the devices.

Method B: Buzzer: When short circuit occurs, the buzzer will sound. Disconnect the controlled electrical devices one by one, if the buzzer does not sound, then short circuit occurs in the device. (Wheel loader electrical devices are connected in parallel)

Method C: Check with circuit interrupter and fluxmeter (gaussmeter): Connect the circuit interrupter to both ends of the fuse, and hold the gaussmeter to test the pulse magnetic field near the conductors along the circuit. The place where the pointer does not move is the short circuit point.

382 Common Fault Diagnosis and Troubleshooting

Fault name	Symptom	Cause	Troubleshooting
Entire loader out of power	When turning on the electric lock, the power relay pull-in cannot be heard and the entire loader's electrical load is powerless	<ol style="list-style-type: none"> 1. Main power switch is not turned on 2. Master power switch is damaged 3. Battery is heavily lack of electricity 4. 80A and 10A fuses blow out 5. Electric lock is damaged 6. Power relay is damaged 7. Battery circuit connectors are loosened 8. Wiring harness connectors are loosened 	<ol style="list-style-type: none"> 1. Turn on the main power switch 2. Replace the main power switch 3. Recharge or replace the battery 4. Check the circuit carefully, find out the cause, and replace the fuse 5. Replace the electric lock 6. Replace the power relay 7. Check and tighten the cable connections 8. Check and connect the relevant connectors again
Start failure	Turn the electric lock to START, but the entire loader does not response	<ol style="list-style-type: none"> 1. The transmission control lever is not engaged to NEUTRAL 2. Transmission control unit is faulty and cannot output neutral signal to starting control circuit 3. Starting interlock relay is faulty 	<ol style="list-style-type: none"> 1. Engage to NEUTRAL 2. Ask professionals for handling 3. Replace starting interlock relay
After starting, starter motor works continuously	Electric lock cannot return to original position	<ol style="list-style-type: none"> 1. The electric lock is stuck and in failure 2. Starting relay contact point is sintered 3. The contact point of starter motor control is sintered 	<ol style="list-style-type: none"> 1. Replace electric lock 2. Replace starting relay 3. Repair or replace starter motor

<p>Starter motor cannot rotate or rotates weakly</p>	<p>Turn the electric lock to START, the starter motor does not response or rotates slowly, resulting in engine start failure</p>	<ol style="list-style-type: none"> 1. Battery is heavily lack of electricity 2. Battery circuit wiring terminal is seriously oxidized and corroded, or loosely connected 3. Starting control circuit faults such as open circuit or poor connection, electric lock damage, and starting relay damage etc. 4. Faults of starter motor control 5. Starter motor DC motor faults 	<ol style="list-style-type: none"> 1. Recharge or replace the battery 2. Polish, clean and tighten the battery connecting circuit 3. Find out the cause, repair the circuit or replace the faulty element 4. Check the pull-in coil or holding coil for short circuit, open circuit, ground, and the contact point and wiring terminal for ablation; handle or replace them 5. Check the starter motor
<p>Starter motor idling</p>	<p>Turn electric lock to START, the starter motor runs at high speed but engine runs slowly</p>	<p>Starter motor transmission mechanism is faulty</p>	<ol style="list-style-type: none"> 1. Check all the one-way clutches for slippage 2. Check driving gear or flywheel ring gear for damage 3. Check driving gear, flywheel ring gear and armature shaft bush for serious wear 4. Check the fork for breakage or disengagement 5. Handle or replace the starter motor depending on actual situation

<p>Starter motor driving gear and flywheel has gear collision</p>	<p>Turn electric lock to START, and the starter motor driving gear and flywheel has gear collision</p>	<ol style="list-style-type: none"> 1. Battery is lack of electricity or faulty 2. Battery circuit wiring terminal is oxidized, corroded or connected loosely 3. Starter motor holding coil is faulty 4. The cut-off voltage for relevant relays in starting control circuit is too high 5. Clearance between driving gear and stop ring is too large 6. Driving gear, flywheel ring gear and armature shaft bush are seriously worn 7. Isolator spring is too soft or broken, and the fork disengages from original position etc. 	<ol style="list-style-type: none"> 1. Recharge or replace the battery 2. Polish, clean and tighten the battery connecting circuit 3. Repair or replace the starter motor 4. Replace the starting relay 5. The last three causes are starter motor inside faults. Repair and replace the starter motor after the specific cause is found out
<p>Auto flame out</p>	<p>Wheel loader can start, but it flames out automatically in a short time</p>	<ol style="list-style-type: none"> 1. Diesel pipe is bent, and fuel supply is unsmooth 2. Flameout control circuit is faulty 	<ol style="list-style-type: none"> 1. Straighten out the fuel supply pipeline 2. Check flameout control circuit



Service Manual

LG936L

Version:0410



4 Power Transmission Propulsion

CONTENTS

4 Power Transmission Propulsion	4-1
41 Transmission Box System	4-2
411 General.....	4-2
412 Basic Parameters of Speed Changer-Torque Converter Assembly.....	4-3
413 Mechanical Principles for Gear Shifting	4-4
414 Oil Supply Principle of Transmission Box.....	4-7
415 Disassembly and Assembly of Transmission System	4-8
42 Transmission Shaft System	4-29
421 Overview of the Transmission Shaft	4-29
422 Replacement of Transmission Shaft.....	4-30
43 Drive Axle System	4-35
431 Overview of Drive Axle	4-35
432 Maintenance of the Drive Axle	4-35
433 Disassembly and Assembly of Drive Axle.....	4-36
44 Diagnosis and Solutions for Common Faults of Transmission System	4-44
441 Fault Diagnosis and Solutions for Transmission box	4-44
442 Fault Diagnosis and Solutions for Drive Axle	4-45

4 Power Transmission Propulsion

Transmission system is composed of transmission box, transmission shaft, front and rear drive axles and wheels. The function of transmission system is that it can transmit the power of power plant to driving wheel and other mechanisms (such as working oil pump, steering oil pump and so on), and deal with all kinds of contradictions between output characteristics of power plant and the power requirements of running gear.

The principle diagram of transmission system is shown in Fig. 4-1.

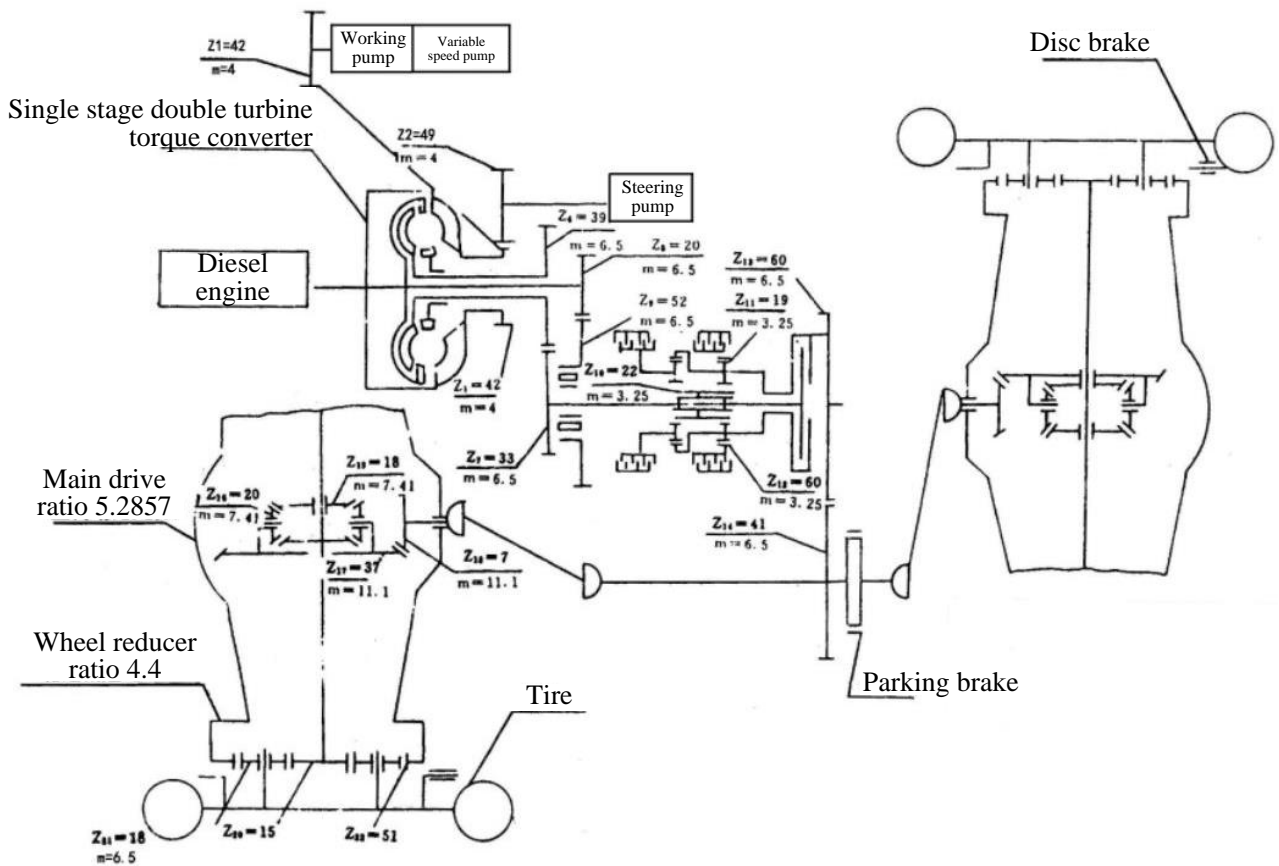

Fig. 4-1 Principle diagram of transmission system

41 Transmission Box System

411 General

A301 transmission box is planetary power gearshift transmission box, matched with single stage four-component double-turbine hydraulic torque converter. Power of motor is transmitted to transmission box via hydraulic torque converter. This transmission box is composed of planetary transmission part and transmission gear part, etc. Its appearance and structure are shown in Fig. 4-2.

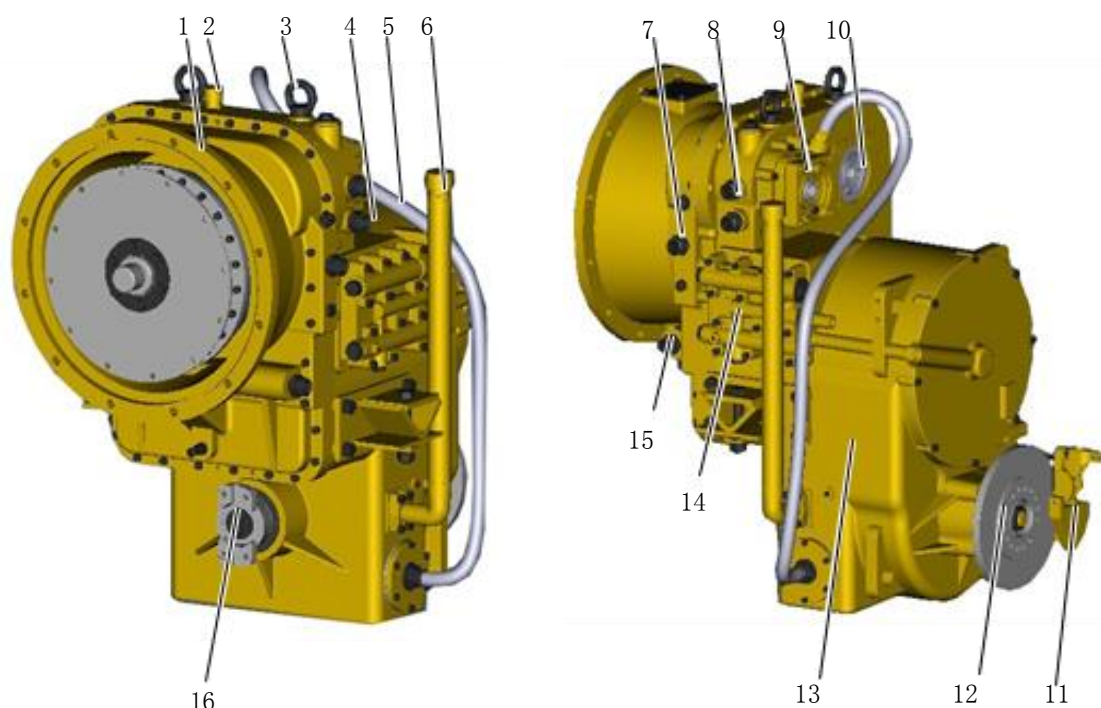

Fig. 4-2

1 Torque converter assembly	2 Vent cap	3 Lifting bolt
4 Oil return port of transmission box	5 Oil absorption pipe	6 O filling pipe
7 Oil outlet port of torque converter	8 Oil outlet port of transmission	9 Variable speed pump
10 To steering pump	11 brake	12 Front output flange
13 Housing	14 Transmission control valve	
15 Torque converter oil return port	16 Rear output flange	

412 Basic Parameters of Speed Changer-Torque Converter Assembly

Table 4-1

Items		Parameters/contents
Torque converter	Type	Single stage four-component double-turbine hydraulic torque converter
	Torque ratio	4.56
	Type of cooling	Circulating water cooling
	Torque converter inlet oil pressure (MPa)	0.45~0.55
	Torque converter outlet oil pressure (Mpa)	0.18~0.25
Transmission box	Type	Planetary power gearshift
	Gears	Forward-2-reverse-1
	Variable speed pump model	CBGj2063/2040
	Gearshift pressure (MPa)	1.1~1.5

413 Mechanical Principles for Gear Shifting

1 Forward gear I

The transmission path diagram is shown in Fig.4-3:

Engine → hydraulic torque converter → first and secondary output gears → intermediate input shaft → sun gear → planet gear I → planet carrier I → direct compression plate → intermediate output gear → output shaft gear → output shaft.

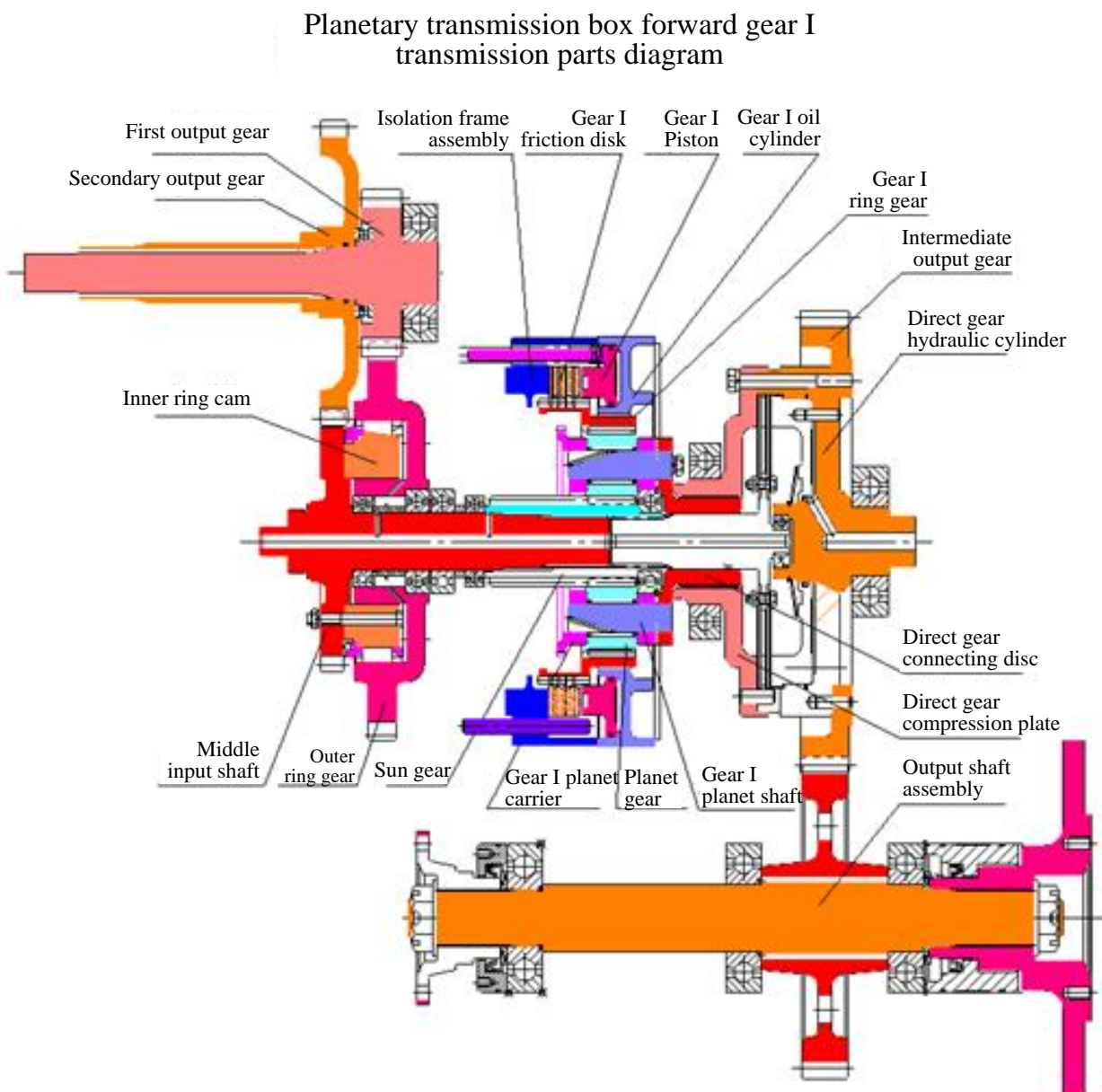

Fig. 4-3

2 Forward gear II

The transmission path diagram is shown in Fig.4-4:

Engine → hydraulic torque converter → first and secondary output gears → intermediate input shaft → sun gear → direct gear shaft → direct gear compression plate → intermediate output gear → output shaft gear → output shaft.

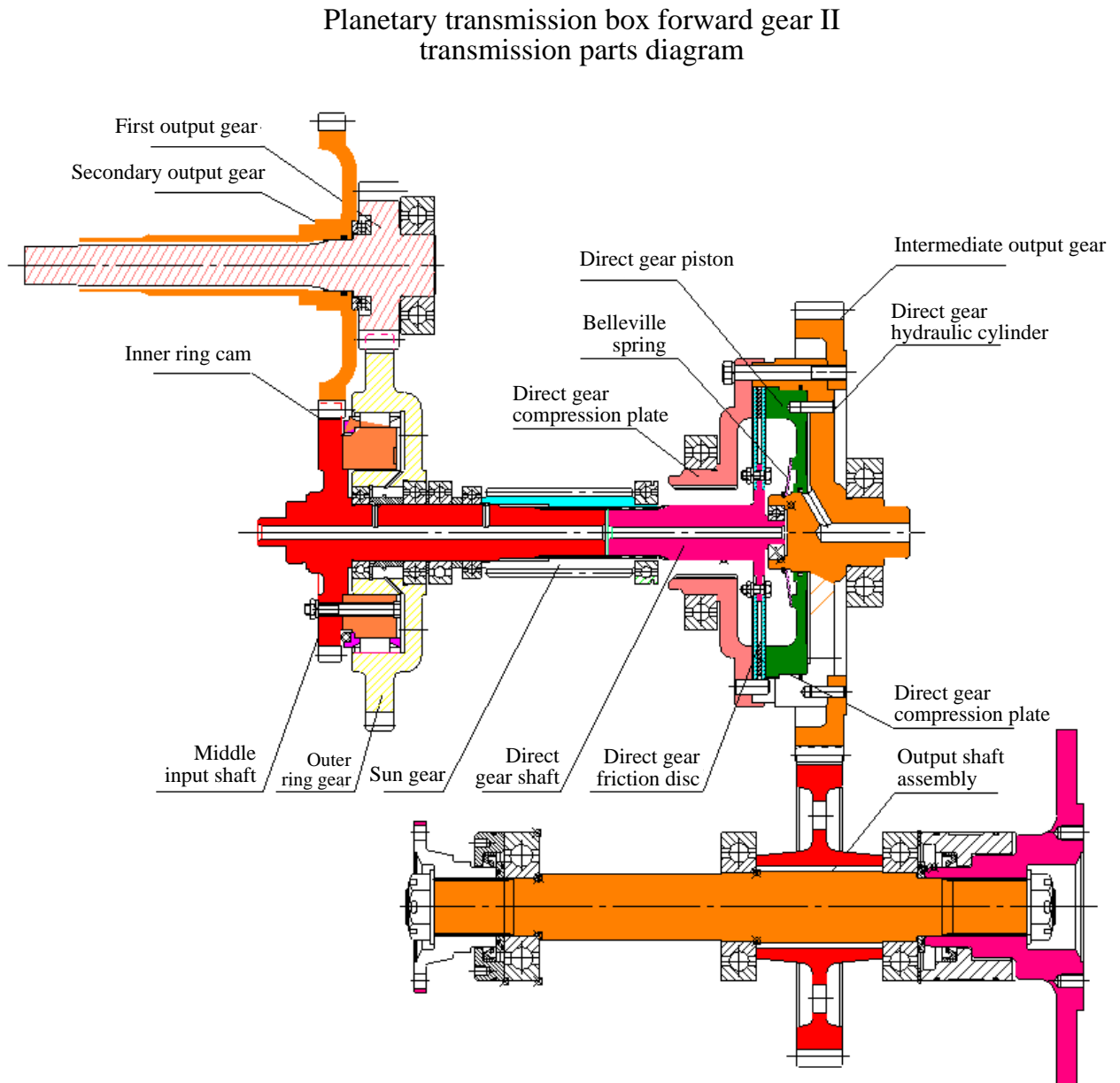

Fig. 4-4

3 Reverse gear I

The transmission path diagram is shown in Fig.4-5:

Engine → hydraulic torque converter → first and the secondary output gears → intermediate input shaft → sun gear → reverse planetary gear → reverse gear ring → gear I planet carrier → direct gear compression plate → intermediate output gear → output shaft gear → output shaft.

Planetary transmission box reverse gear transmission parts diagram

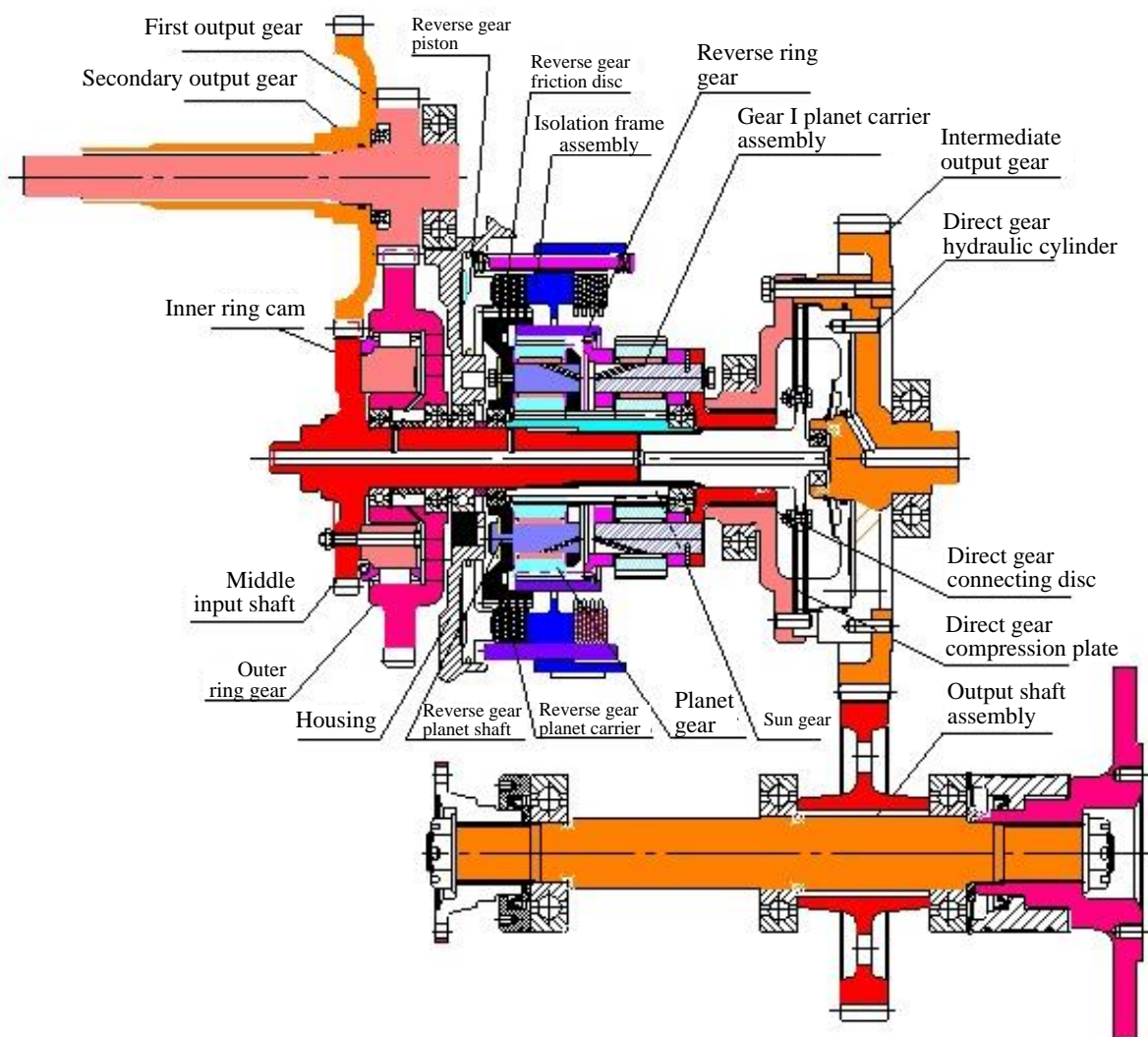

Fig. 4-5

414 Oil Supply Principle of Transmission Box

Working principle of transmission box-torque converter oil supply system is shown in Fig.4-6:

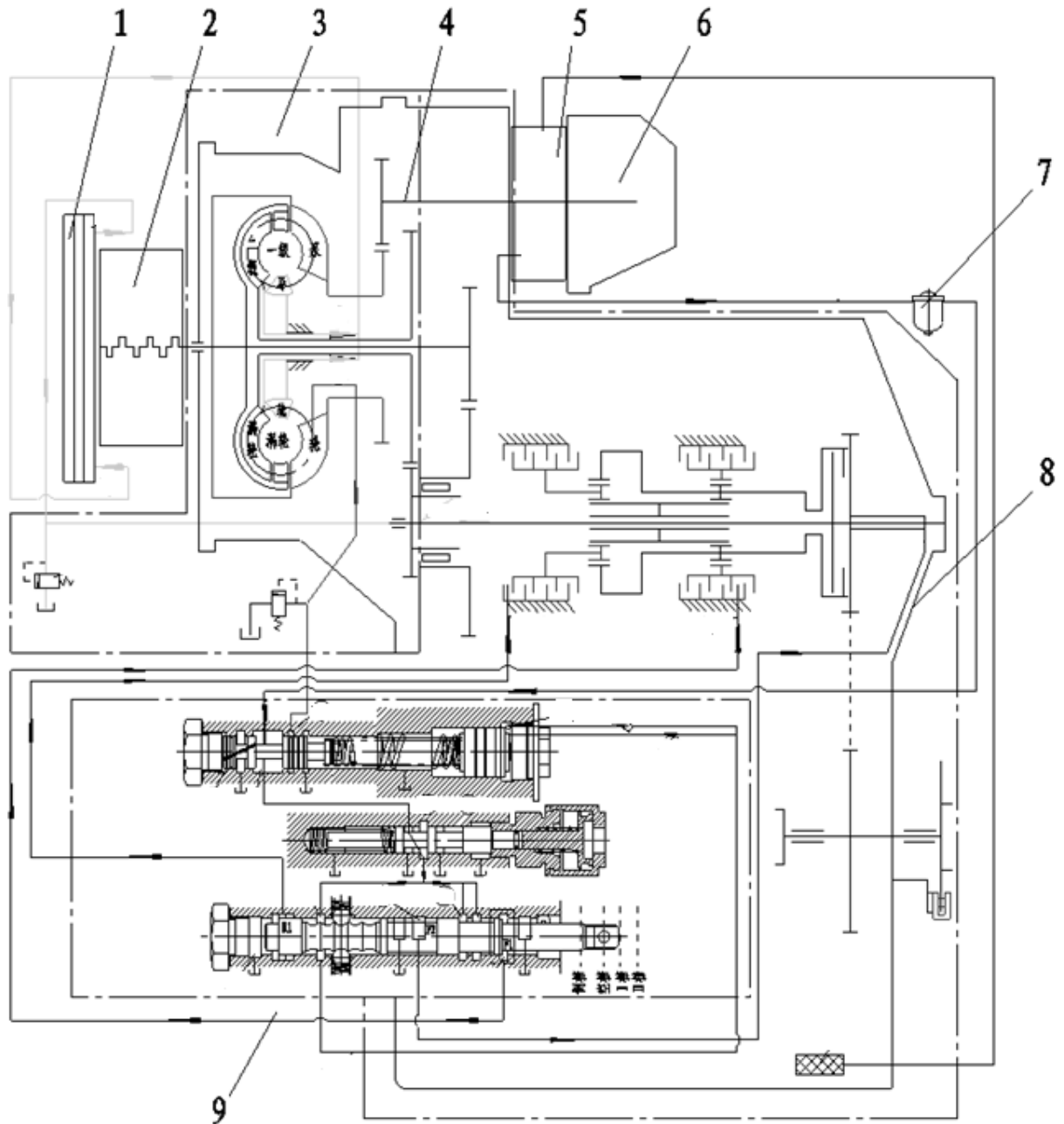

Fig. 4-6

- | | | | |
|-----------------------|------------------------------|--------------------|--------|
| 1 Radiator | 2 Diesel engine | 3 Torque converter | 4 Gear |
| 5 Variable speed pump | 6 Working pump | 7 Oil filter | |
| 8 Transmission box | 9 Transmission control valve | | |

415 Disassembly and Assembly of Transmission System

Disassembly of transmission box

Refer to following steps to remove the transmission box off the machine:

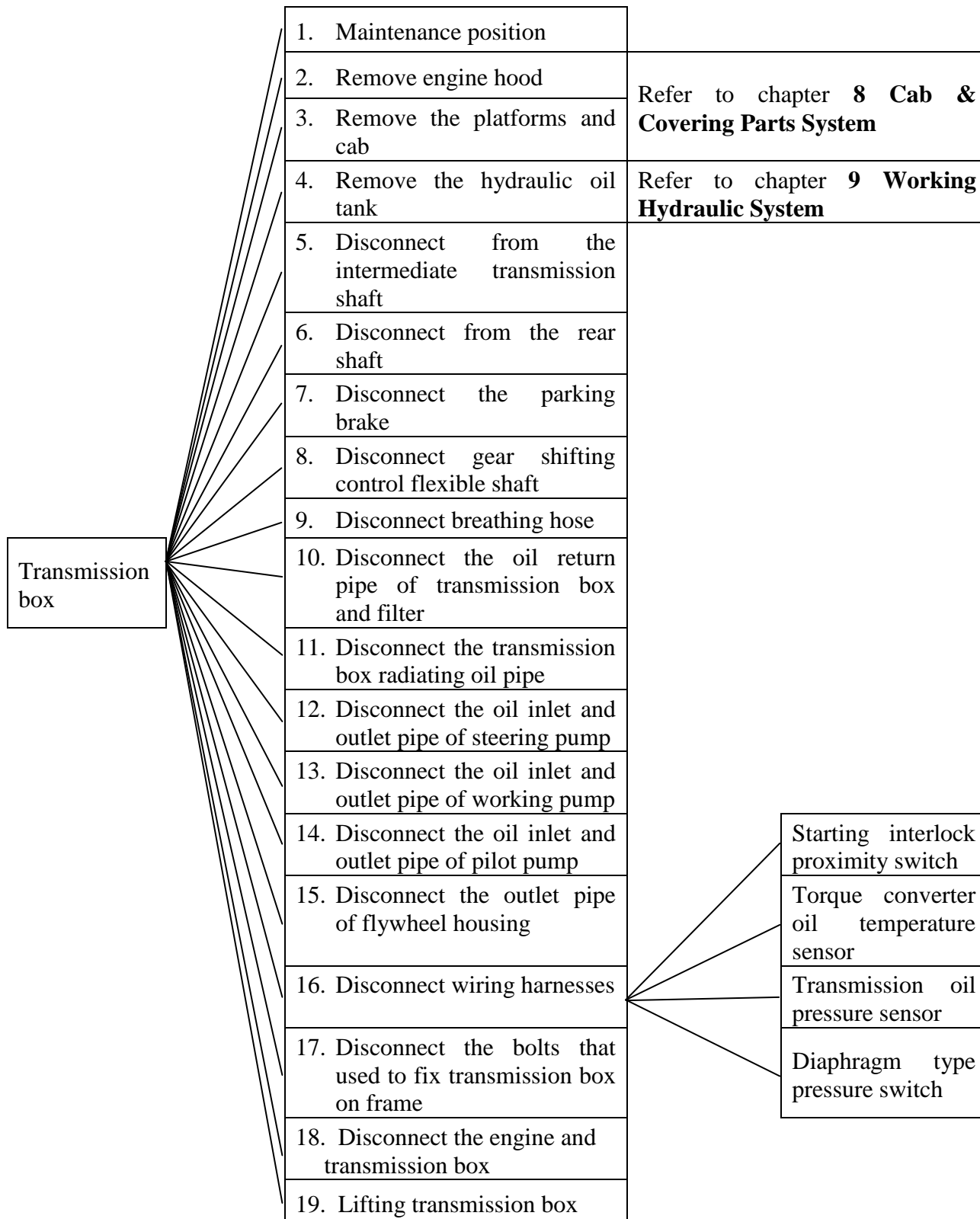



1

Fig. 4-7
1 LG936L loader



1

Fig. 4-8
1 Engine hood



1

Fig. 4-9
1 Driving cab

★ ATTENTION

- Wait until the transmission box is cooled down to do the disassembly.
- In the process of disassembly, the joints of each pipeline should be bound up to avoid the sundries entering into the pipelines.

1. Put the loader in maintenance position.

2. Remove engine hood, refer to **8 Cab & Covering Parts System**.

3. Remove the cab and left and right platforms, refer to **8 Cab & Covering Parts System**.

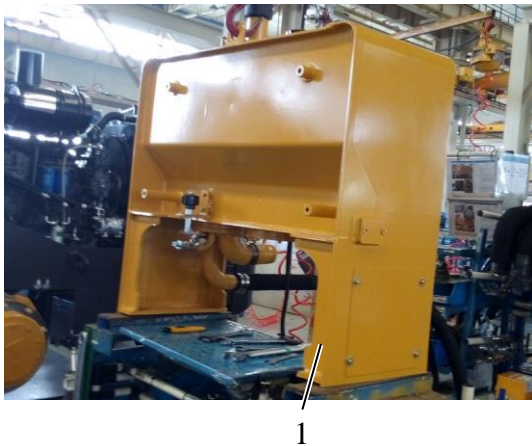

Fig. 4-10
1 Hydraulic oil tank

4. Remove the hydraulic oil tank, refer to **9 Working Hydraulic System** for disassembly and assembly of hydraulic oil tank.

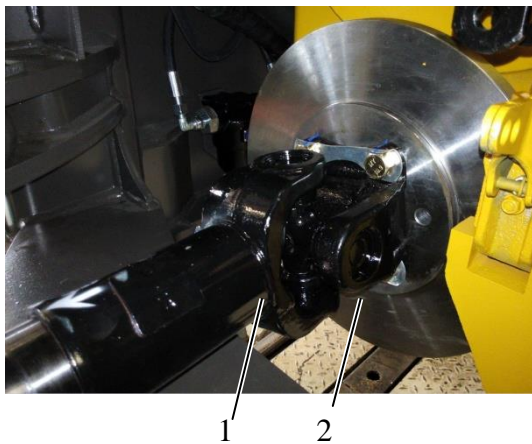

Fig. 4-11
1 Transmission shaft
2 Transmission box front flange

5. Disconnect transmission box and intermediate shaft.

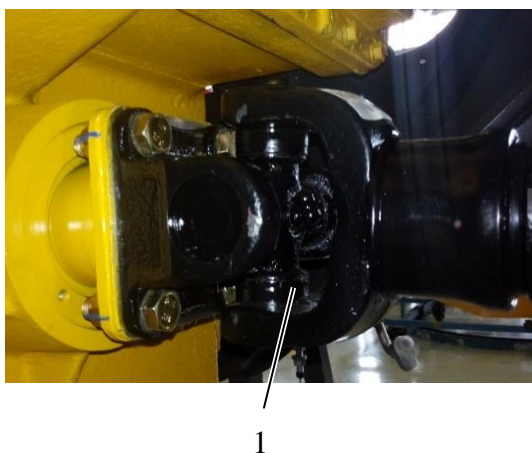

Fig. 4-12
1 Rear transmission shaft

6. Remove the bolts that connecting transmission box rear flange and transmission shaft.



Fig. 4-13
1 Drain plug

7. Remove the filling pipe of transmission box and drain transmission oil out.

★ATTENTION

- With a clean container, and cover up the protection to avoid Debris falling into.
- Be careful of the oil spillage.

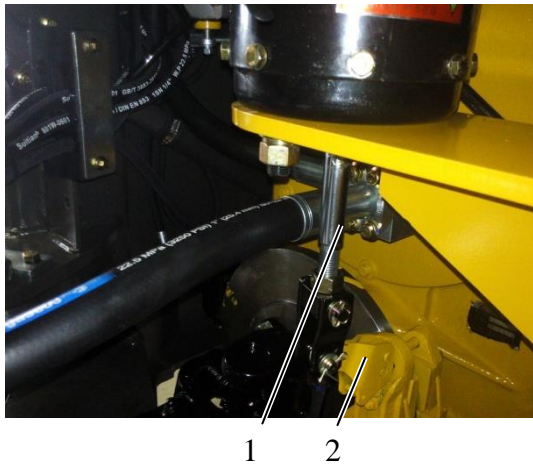

Fig. 4-14
1 Parking brake air chamber
2. Parking brake

8. Disconnect the parking brake air chamber from the parking brake

★ATTENTION

- Parking brake must be relieved before the disconnecting, and the wood blocks should be placed under the tires to avoid unexpected moving of machine.

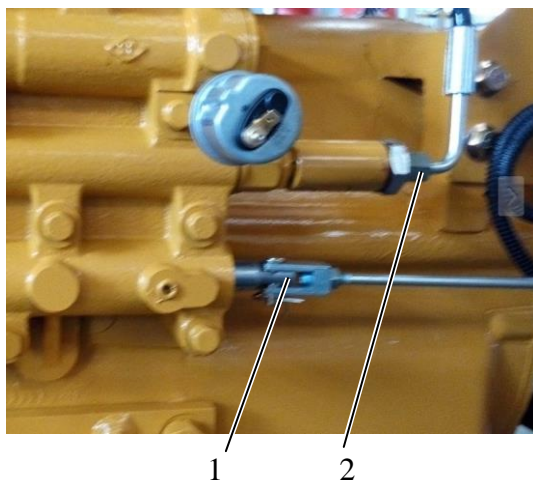

Fig. 4-15
1 Gear shifting control flexible
2. Pressure cutoff valve oil pipe

9. Disconnect the gear shifting control flexible shaft from speed change valve, and disconnect the oil pipe of pressure cut-off valve.



1

Fig. 4-16

1 Hose between transmission box and respirator

10. Disconnect the hose between transmission box and breather.



1

2

Fig. 4-17

1 Oil return pipe of transmission box
2 Oil outlet pipe of transmission box

11. Disconnect the oil outlet and return pipes of transmission box.

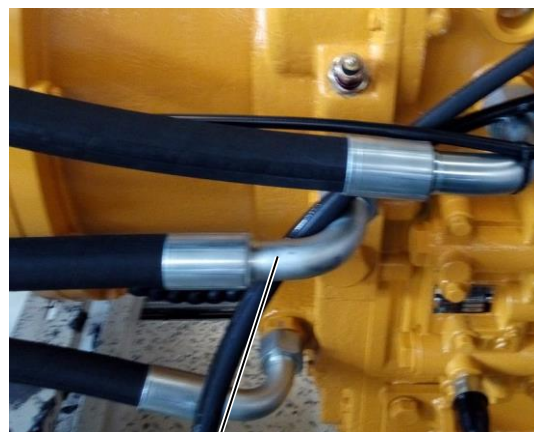

1

Fig. 4-18

1 Oil pipe between transmission box and radiator

12. Disconnect the oil pipe between transmission box and radiator.

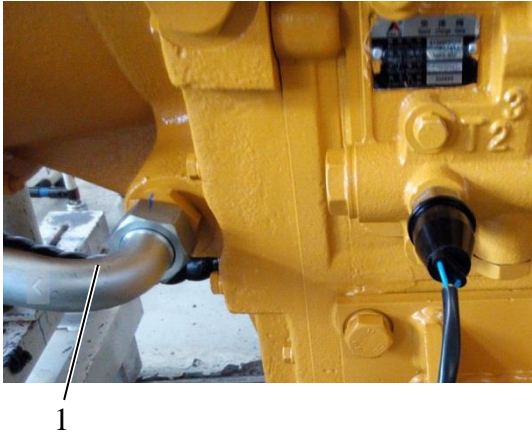

Fig. 4-19
1 Radiating oil return pipe

13. Disconnect the radiating oil return pipe from transmission box.

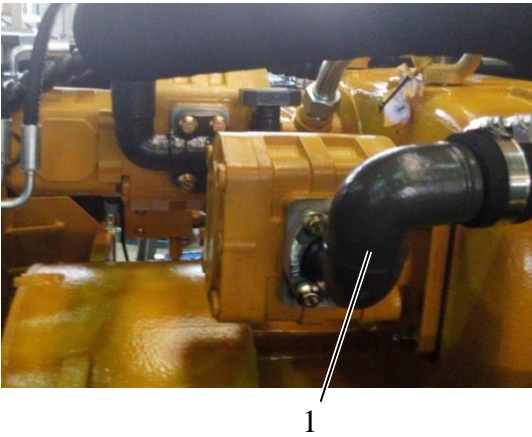

Fig. 4-20
1 Steering pump absorption pipe

14. Disconnect the oil absorption pipe of steering pump.

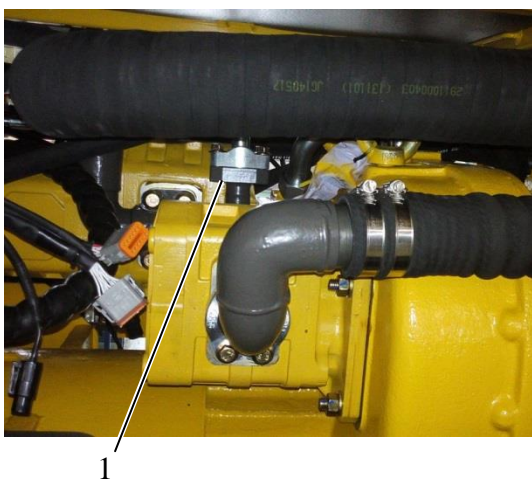

Fig. 4-21
1 Steering pump oil outlet pipe

15. Disconnect steering pump oil outlet pipe from priority valve.

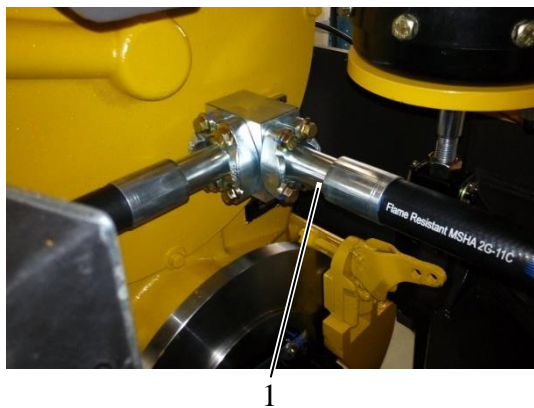

Fig. 4-22
1 Multi way valve oil inlet hose

16. Disconnect the connection between multitandem valve oil inlet hose and two-junction.

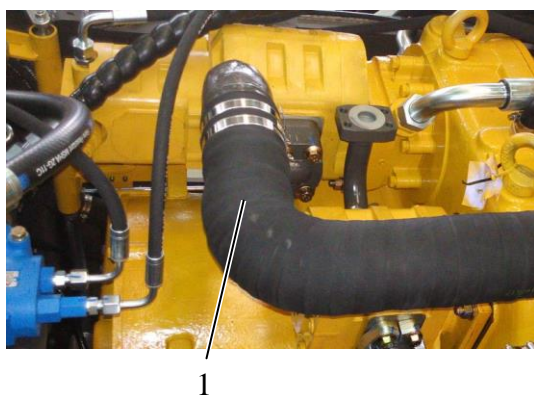

Fig. 4-23
1 Working pump oil absorption pipe

17. Disconnect working pump oil absorption steel pipe.

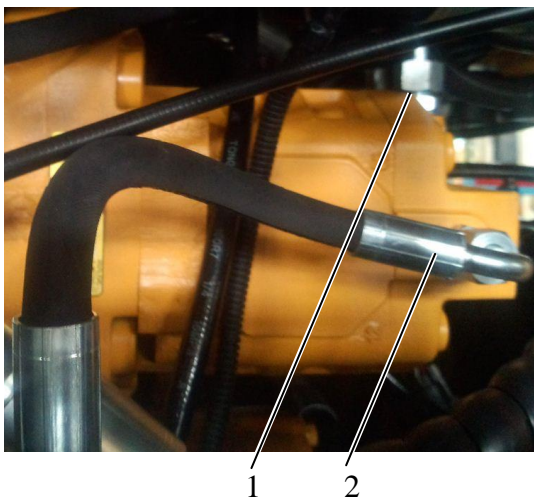

Fig. 4-24
1 Pilot pump oil return pipe
2 Pilot pump oil outlet pipe

18. Disconnect oil outlet and return pipes of pilot pump.



Fig. 4-25
1 Oil return pipe

19. Disconnect the oil return pipe of flywheel housing.



Fig. 4-26
1 Reverse pressure switch

20. Disconnect reverse pressure switch wiring harness.

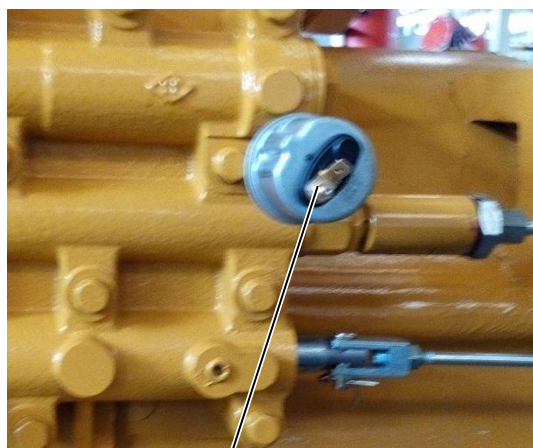

Fig. 4-27
1 Transmission oil pressure sensor

21. Disconnect transmission oil pressure sensor wiring harness.

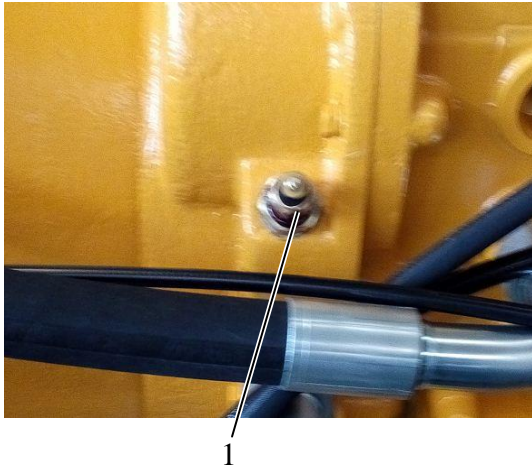

Fig. 4-28
1 Torque converter oil temperature sensor

22. Disconnect torque converter oil temperature sensor wiring harness.

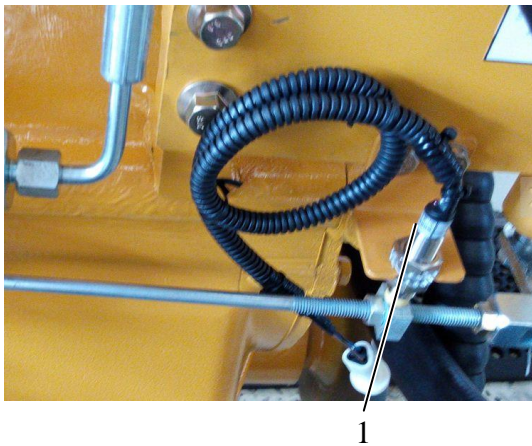

Fig. 4-29
1 Starting interlock proximity switch

23. Disconnect starting interlock proximity switch wiring harness.



Fig. 4-30
1 Bolt

24. Remove bolts that used to fix speed changer-torque converter assembly on frame.



1

Fig. 4-31
1 Wood block

25. Lift the speed changer-torque converter assembly up for a certain distance, and put a wood block between engine and auxiliary frame, to keep the engine stable.



1

2

Fig. 4-32
1 Bolt 2 Cover plate

26. Remove the fixing bolts of cover plate, and take the plate and gaskets down.



1

Fig. 4-33
1 Window

27. Remove the nuts and gaskets that used to connect flywheel and flywheel transition plate.

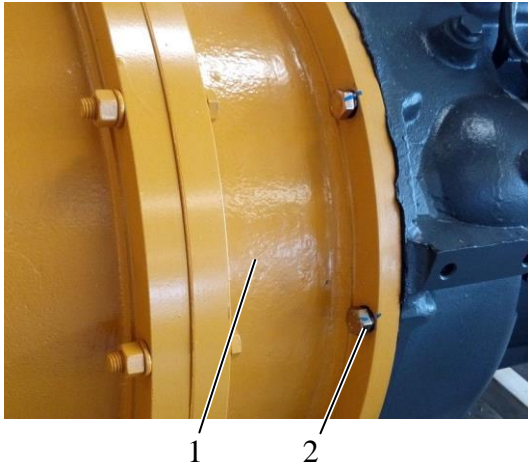

Fig. 4-34

1 Flywheel transition housing

2. Bolt



Fig. 4-35

28. Dismount fixed bolts and gaskets of flywheel transition housing.

29. Gently waggle the speed changer-torque converter assembly to disconnect it from engine, and lift the speed changer-torque converter assembly forward to make sure that there is a certain gap between the flywheel transition housing and engine housing, and then slowly lift speed changer-torque converter assembly up.

★ ATTENTION

- **Lift the transmission box smoothly to prevent the torque converter slipping.**
- **Please be careful during operation and pay special attention to the cables and hydraulic hoses on the machine, otherwise, they may be damaged by clamping or extruding. Align the transmission box intermediate ring to flywheel housing.**

Assembly of the transmission box

Refer to the following steps to recover the transmission box:

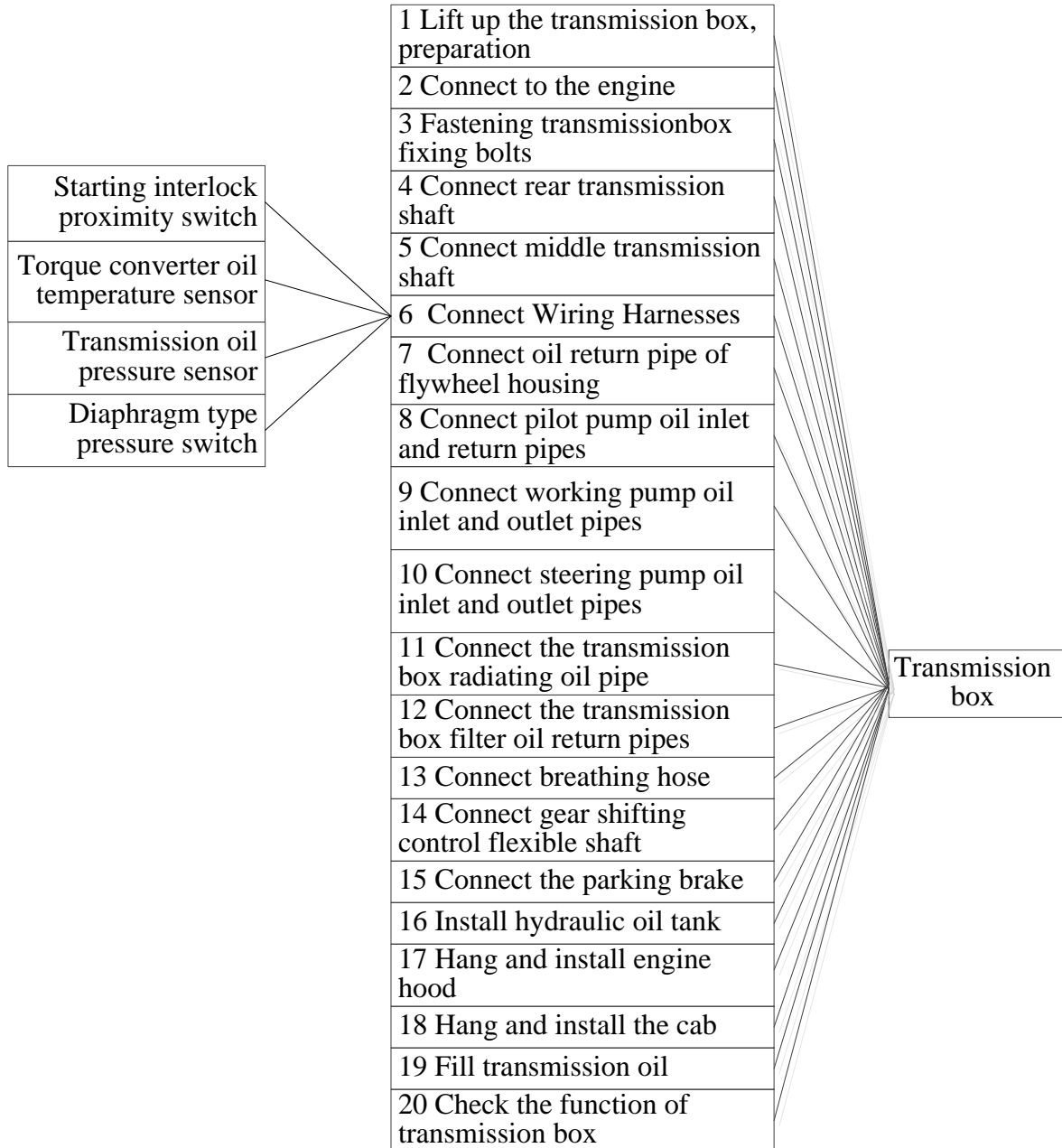



1

Fig. 4-36

1 Transmission box

1. Connect the lifting appliance to the transmission box.
2. Lift the transmission box to the right position.

★ATTENTION

- Lift the transmission box smoothly to prevent the torque converter slipping.
- Please be careful during operation and pay special attention to the cables and hydraulic hoses on the machine, otherwise, they may be damaged by clamping or extruding. Align the transmission box intermediate ring to engine flywheel housing.

3. Connect the flywheel transition housing and to engine flywheel housing.

 Nm 45~50Nm

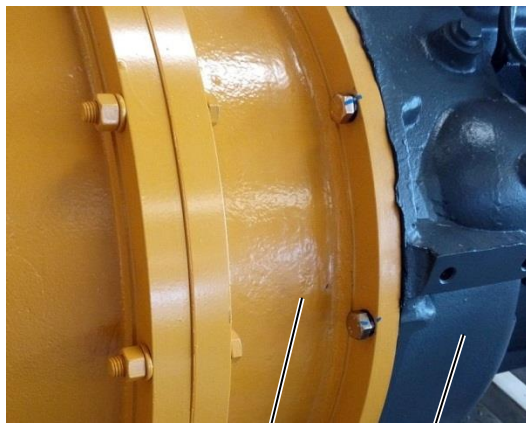

1

2

Fig. 4-37

1 Flywheel transition housing

2 Engine

4. Connect flywheel and flywheel transition plate with nuts and gaskets.

★ATTENTION

- Be careful and make sure no nut and washer falling into the flywheel housing.

 Nm 45~59Nm



1

Fig. 4-38

1 Window

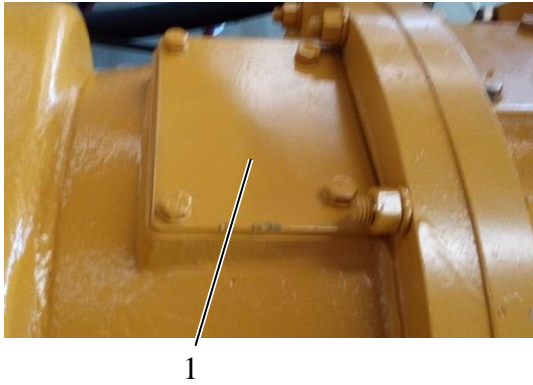
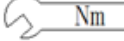

Fig. 4-39
1 The gland

5. Install the cover plate.

 Nm 22~30Nm

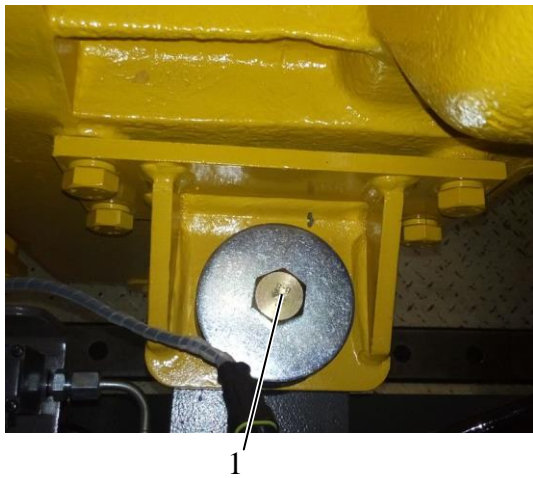
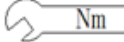

Fig. 4-40
1 Bolt

6. Tighten the fastening bolts of transmission box.

 Nm 120~200Nm

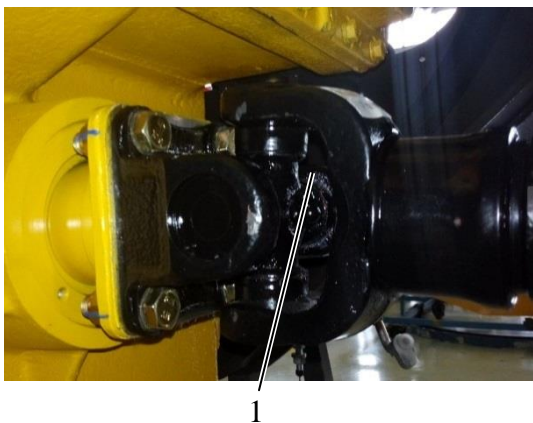
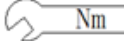

Fig. 4-41
1 Rear transmission shaft

7. Connect transmission box and rear transmission shaft.

★ATTENTION

Align the orientation arrow of the two transmission shafts

 Nm 145±20Nm

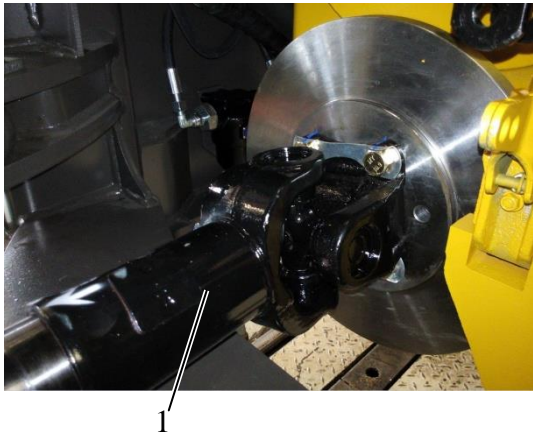



Fig. 4-42

1 Intermediate transmission shaft

8. Connect intermediate transmission shaft.

★ATTENTION

Align the orientation arrow of the two transmission shafts

 Nm 145 ±20Nm

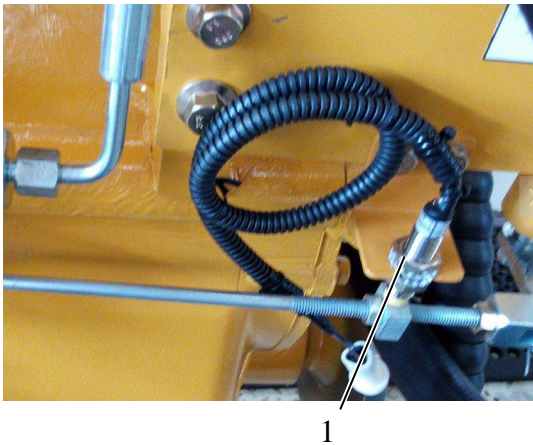

Fig. 4-43

1 Starting interlock proximity switch

9. Connect the starting interlock proximity switch wiring harness.

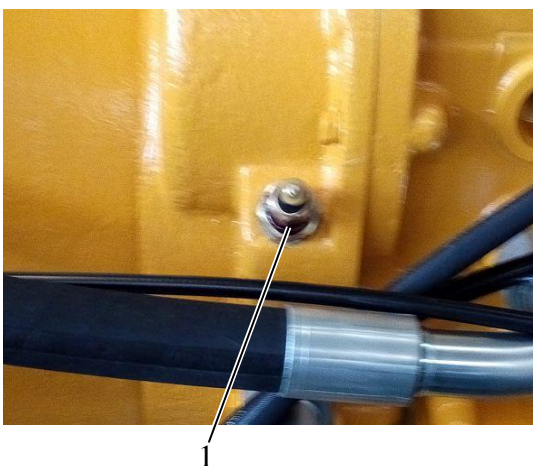
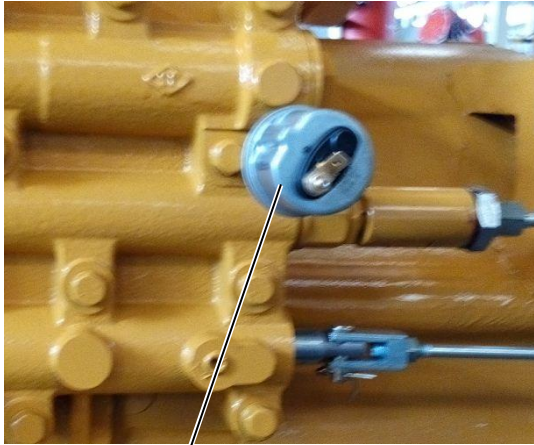

Fig. 4-44

1 Torque converter oil temperature sensor

10. Connect torque converter oil temperature sensor wiring harness.



1

Fig. 4-45
1 Transmission oil pressure sensor

11. Connect the transmission oil pressure sensor wiring harness.



1

Fig. 4-46
1 Reverse pressure switch.

12. Connect the reverse pressure switch wiring harness.

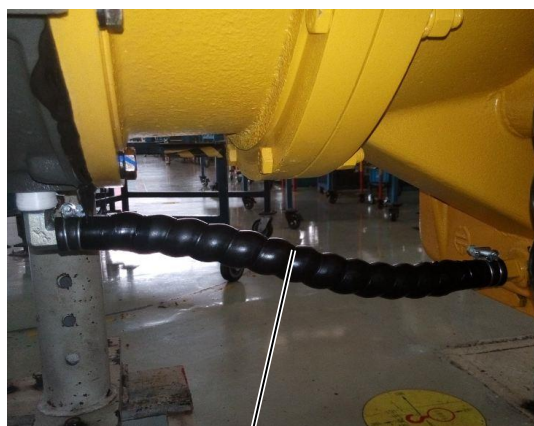

1

Fig. 4-47
1 Oil Return pipe.

13. Connect the oil return pipe of flywheel housing.

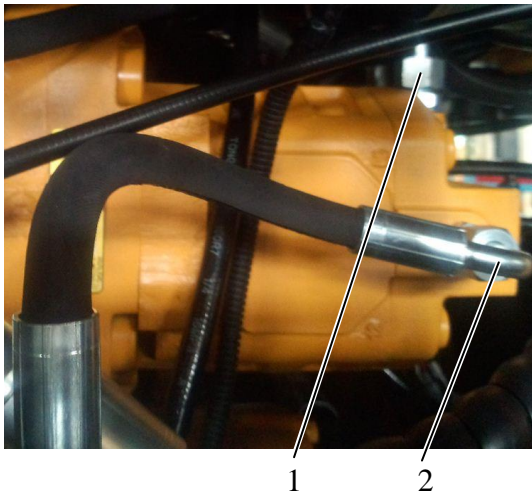



Fig. 4-48

- 1 Oil return pipe of pilot pump
- 2 Oil outlet pipe of pilot pump

14. Connect the oil return and outlet pipes of pilot pump.

★ ATTENTION

Check the O-shape ring in pipe joint before installing.

 Nm 15~20Nm

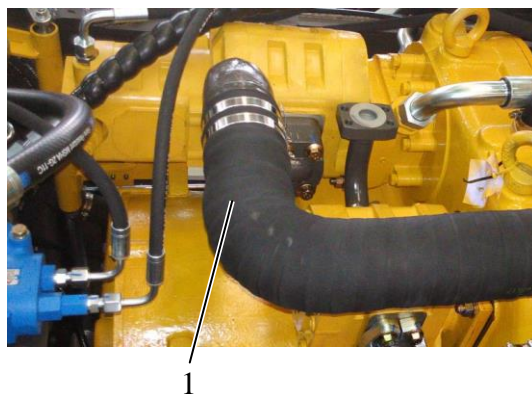



Fig. 4-49

- 1 Oil absorption pipe of working pump

15. Connect the oil absorption pipe of working pump.

 Nm 78~104Nm

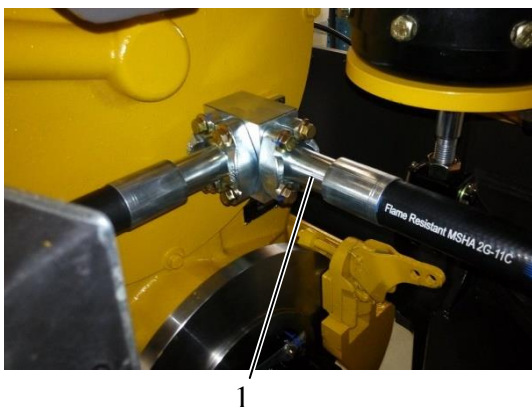



Fig. 4-50

- 1 Two-junction

16. Connect multitan-dem valve oil inlet hose to the two-junction.

★ ATTENTION

Check the O-shape ring in pipe joint before installing.

 Nm 45~59Nm



1

Fig. 4-51

1 Steering pump oil outlet pipe

17. Connect steering pump oil outlet pipe.

★ATTENTION**Check the O-shape ring in pipe joint before installing.** Nm 45~59Nm

1

Fig. 4-52

1 Oil absorption pipe of steering pump

18. Connect oil absorption pipe of steering pump.

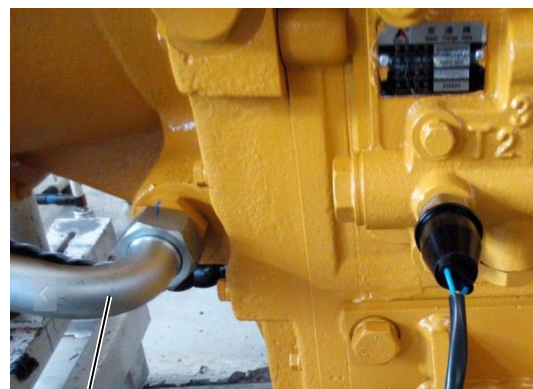
★ATTENTION**Check the O-shape ring in pipe joint before installing.** Nm 45~59Nm

1

Fig. 4-53

1 Radiating oil return pipe

19. Connect radiating oil return pipe.

★ATTENTION**Check the O-shape ring in pipe joint before installing.** Nm 120~145Nm

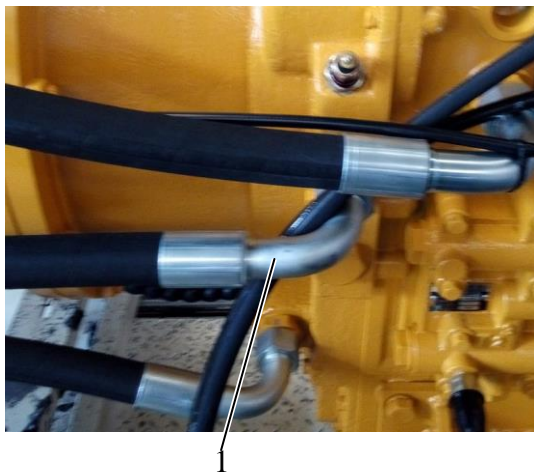



Fig. 4-54

1 Oil pipe from transmission box to radiator

20. Connect oil pipe from transmission box to heat radiator.

★ ATTENTION

Check the O-shape ring in pipe joint before installing.

 Nm 120~145N m

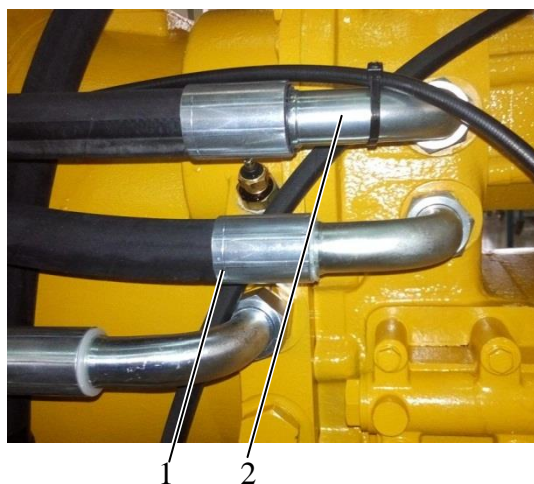

Fig. 4-55

1 Oil return pipe of transmission box
2 Oil outlet pipe of transmission box

21. Connect the oil outlet and return pipes of transmission box.

★ ATTENTION

Check the O-shape ring of the hose joint before installing.

 Nm 120~145N m



Fig. 4-56

1 Breathing hose

22. Connect the breathing hose.

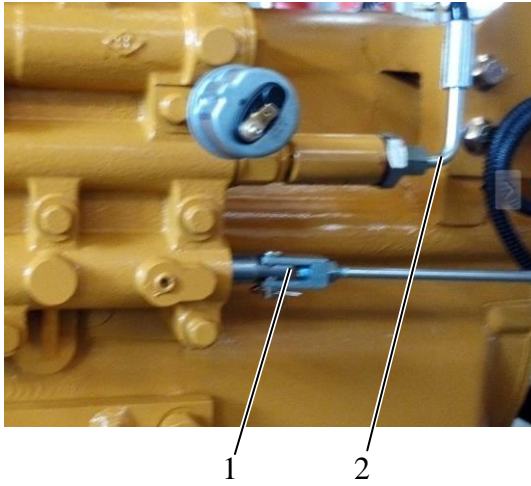

Fig. 4-57
1 Gear shifting control flexible shaft
2 Pressure cut-off valve oil pipe

- 23. Connect gear shifting control flexible shaft to speed change valve. Disconnect the oil pipe of pressure cut-off valve.

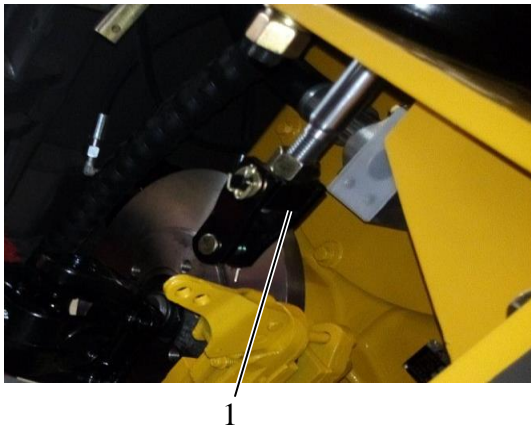

Fig. 4-58
1 Parking brake

- 24. Connect the parking brake.

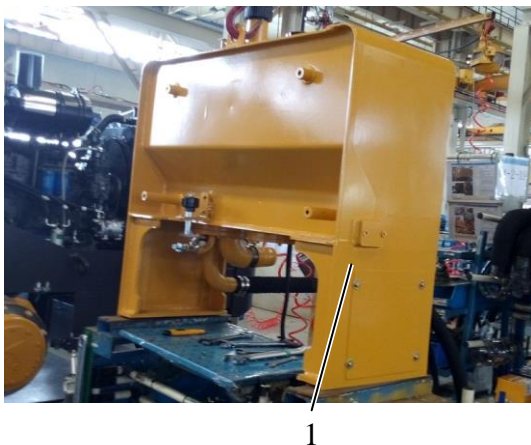

Fig. 4-59
1 Hydraulic pressure tank

- 25. Assemble hydraulic pressure oil tank.



1

Fig. 4-60
1 Engine hood

26. Assemble engine hood. Refer to **8 Cab & Covering Parts System** for details.



1

Fig. 4-61
1 Driving cab

27. Assemble the cab. Refer to **8 Cab & Covering Parts System** for details.

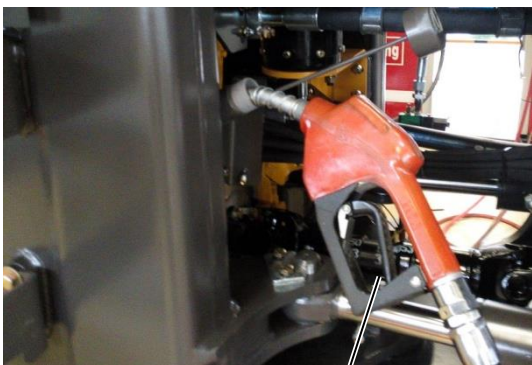

1

Fig. 4-62
1 Oil filling device

28. Fill hydrodynamic drive oil, refer to **1 Maintenance & Repair** for requirements.

42 Transmission Shaft System

421 Overview of the Transmission Shaft

1. Structure and function of universal transmission device

Universal transmission device of the loader is installed between the transmission box and the drive axle. It usually consists of a universal joint assembly and transmission shaft, etc. (Universal transmission device is customarily called transmission shaft assembly). Some loaders also equipped with intermediate support in universal transmission device. Structures of the front and rear transmission shafts are shown in the following figures.

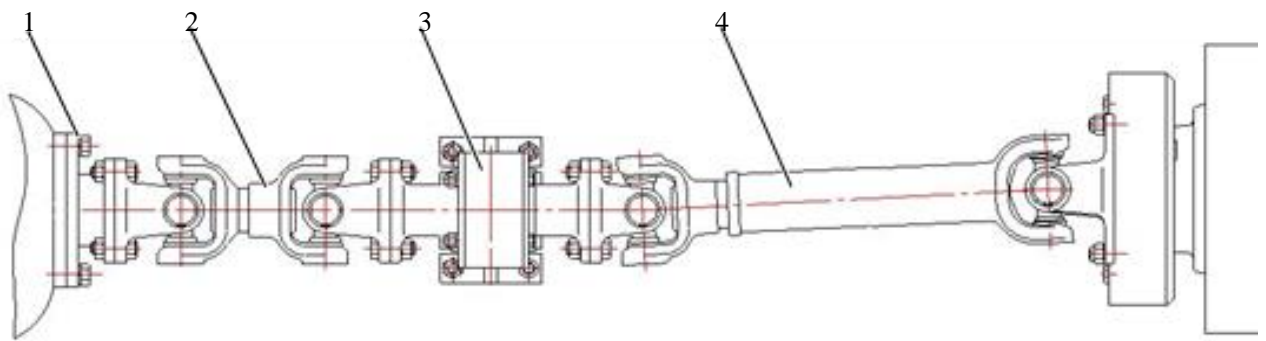

Fig. 4-63

- | | |
|------------------------|-----------------------------------|
| 1 Hexagon bolt | 2 Front transmission shaft |
| 3 Intermediate support | 4 Intermediate transmission shaft |

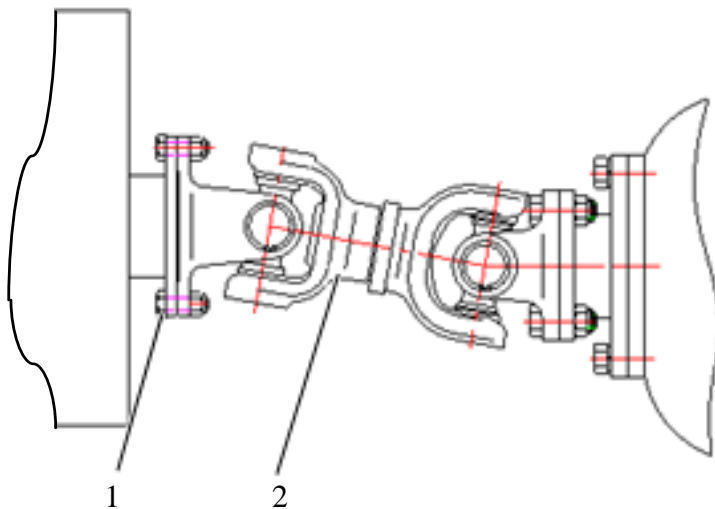

Fig. 4-64

- | | |
|----------------|---------------------------|
| 1 Hexagon bolt | 2 Rear transmission shaft |
|----------------|---------------------------|

Due to the axes of the loader transmission box output shaft and drive axle input shaft are difficult to be aligned in line; moreover, during the loader operation process, due to the uneven road and working site, the relative position of the two axes changes frequently. So we can't apply rigid

connection between the output shaft of the transmission box and the input shaft of the drive axle, while we must adopt the universal transmission device, which is made of two cross universal joints and a drive shaft.

The function of the universal transmission device is to solve the uncoaxiality between the transmission box and the drive axle, to meet the needs of angle changing between the transmission box and the drive axle, and pass the power of transmission box to the drive axle.

2. Structure and characteristic of transmission shaft

The transmission shaft is an important part of the universal transmission device, usually used for the connection between the transmission box and drive axle. Generally speaking, the transmission shaft is composed of pipe sleeve fork assembly, universal joint fork and spline shaft assembly, etc. During the operation of the loader, the relative position of the transmission box and drive axle changes constantly, in order to avoid movement interference, the transmission shaft has sliding splined connection parts, which consisting of sliding fork and spline shaft, so as to realize the change of the length of the transmission shaft. In order to reduce abrasion, the transmission shaft is equipped with filling grease oil cup, oil seal and spline sheath, etc. to ensure the lubrication of the spline shaft in the sleeve fork, and prevent water and dust entering into the sliding spline.

422 Replacement of Transmission Shaft

Replacement of the front transmission shaft

1. Disconnect the connection between the front transmission shaft assembly and intermediate support.

★ ATTENTION

- Set the loader in maintenance position before disassembling.
- Press down parking brake switch.

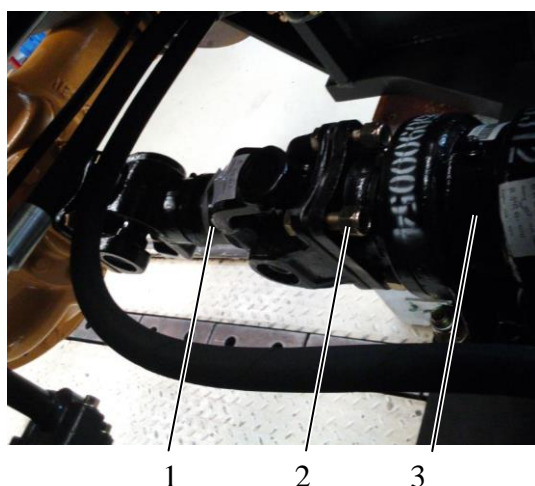

Fig. 4-65

- 1 Front transmission shaft
- 2 Bolt
- 3 Supporting seat

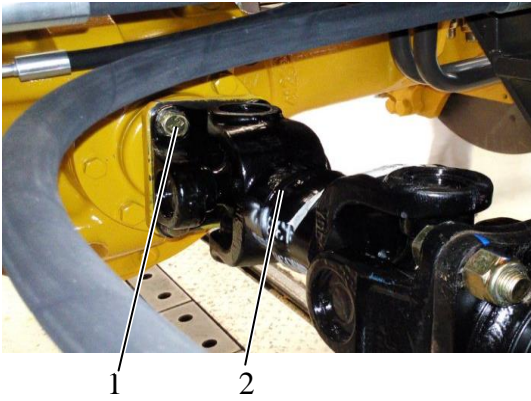

Fig. 4-66
1 Bolt
2 Front transmission shaft

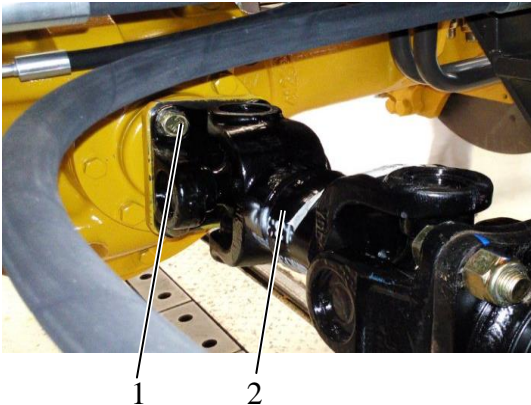

Fig. 4-67
1 Bolt
2 Front transmission shaft

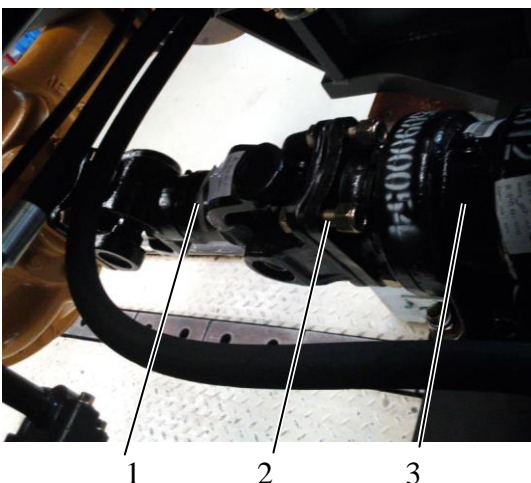
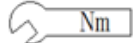

Fig. 4-68
1 Front transmission shaft
2 Bolt
3 Supporting seat

2. Disconnect the front transmission shaft assembly from front drive axle.

3. Replace the transmission shaft and connect the new front transmission shaft assembly to front drive axle.

 Nm 145 ±20Nm

★ ATTENTION

Align the orientation arrow of the two transmission shafts.

4. Assemble the connection between the front transmission shaft assembly and intermediate support.

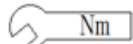
 Nm 145 ±20Nm

★ ATTENTION

Align the orientation arrow of the two transmission shafts.

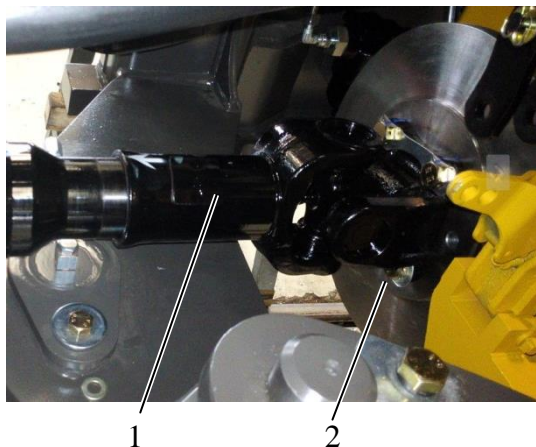
Fig. 4-69

- 1 Intermediate transmission shaft
- 2 Transmission box flange

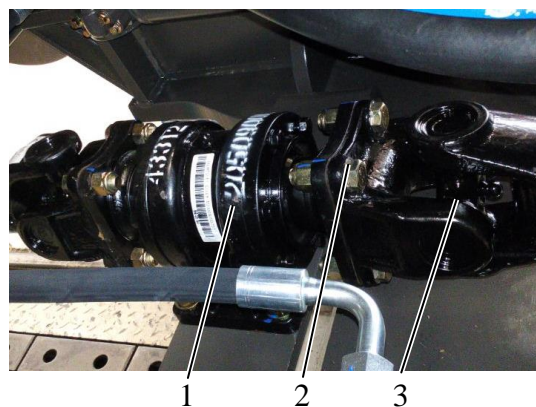
Fig. 4-70

- 1 Supporting seat
- 2 Bolt
- 3 Middle transmission shaft

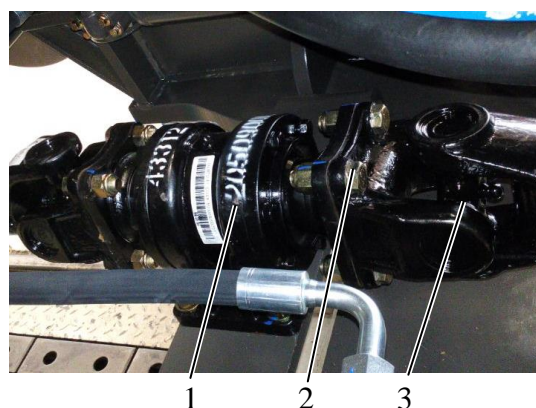
Fig. 4-71

- 1 Supporting seat
- 2 Bolt
- 3 Intermediate transmission shaft

Replacement of the intermediate transmission shaft

1. Remove the connection between the intermediate transmission shaft assembly and the transmission box.

2. Disconnect the intermediate transmission shaft assembly from intermediate support.

3. Replace the transmission shaft and connect the new intermediate transmission shaft assembly to intermediate support.

 Nm 145 ±20Nm

★ ATTENTION

Align the orientation arrow of the two transmission shafts.

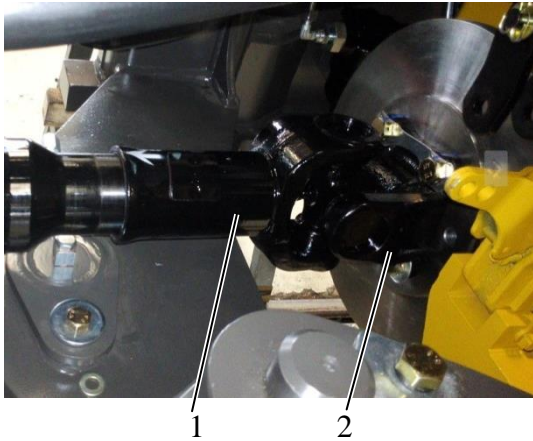



Fig. 4-72

1 Hexagon bolt

2 Intermediate transmission shaft

4. Connection the intermediate transmission shaft assembly to transmission box.

 Nm 145 ±20Nm

★ ATTENTION

Align the orientation arrow of the two transmission shafts.

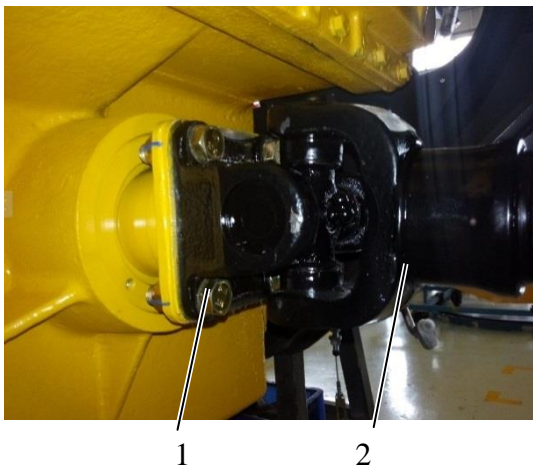

Fig. 4-73

1 Hexagon bolt

2 Rear transmission shaft

Replacement of the rear transmission shaft

1. Remove the connection between the rear transmission shaft assembly and the transmission box.

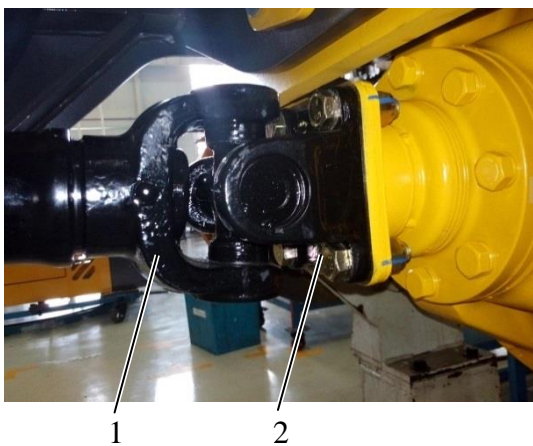

Fig. 4-74

1 Rear transmission shaft

2 Hexagon bolt

2. Remove the connection between the rear transmission shaft assembly and rear drive axle.

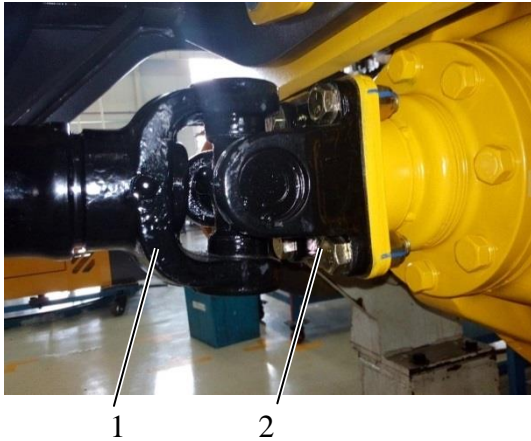

Fig. 4-75

- 1 Rear transmission shaft
- 2 Hexagon bolt

3. Replace the transmission shaft and connect the new rear transmission shaft assembly to rear drive axle.

★ATTENTION

Align the orientation arrow of the two transmission shafts.

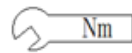
 Nm 145 ±20Nm

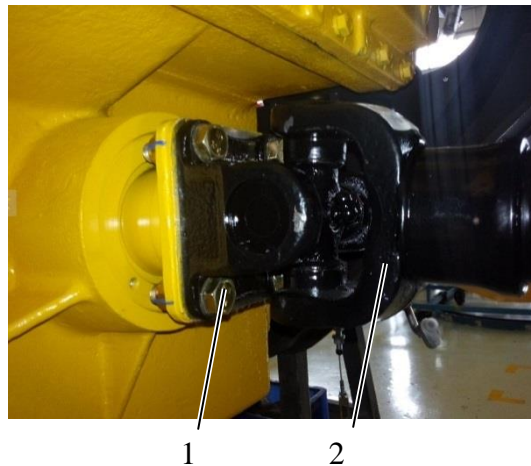

Fig. 4-75

- 1 Rear transmission shaft
- 2 Hexagon bolt

4. Connect rear transmission shaft assembly and to transmission box.

★ATTENTION

Align the orientation arrow of the two transmission shafts.

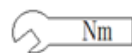
 Nm 145 ±20Nm

43 Drive Axle System

431 Overview of Drive Axle

Drive axle locates at the end of wheel loader transmission system, it is a general term that describes all the transmission mechanisms between transmission shaft and driving wheel. Drive axle is mainly used to transmit the torque of transmission shaft to driving wheels, it also works as a differential to realize differential speed between left side and right side wheels. Moreover, drive axle housing also plays a role of load-bearing and stress-passing.

432 Maintenance of the Drive Axle

1. Check the oil level

—Place the loader horizontally. Wipe up all oil filling ports before checking. Oil draining shall be carried out after the loader travels for a period of time. When unscrewing the screw to drain or add oil, be careful of hot oil splashing.

—Types of oil level: When check wheel side oil level, you should rotate wheel hub until the plug is at 3 o'clock position (as shown in the figure below). Fill oil until there is overflow.



Fig. 4-77

Oil level of the drive axle: Oil level is subjected to overflow of plug hole or oil filling port.

—Check: If the oil level drops a few minutes later, add oil until the oil level reaches required level and keep stable.

Check oil level once a month.

2. Change oil

Replace the drive axle oil after the first 500h working hours, since then change the oil every 1,000 working hours, and oil should be change at least once a year.

If any of the following case is involved, we recommend you to replace the drive axle oil every 500 hours or at least once every six months.

- Frequent operating brake or poor working conditions.
- Ambient temperature of operating conditions exceeds 40°C.

3. Working temperature

Continuous working temperature for drive axle should not exceed 90°C. If the temperature exceeds 120°C, stop the loader to check the brake system and the drive axle.

433 Disassembly and Assembly of Drive Axle

Disassembly of rear drive axle

1. Remove the two wheels of the rear axle.
Refer to **7 Frames, Tire & Working Device**.

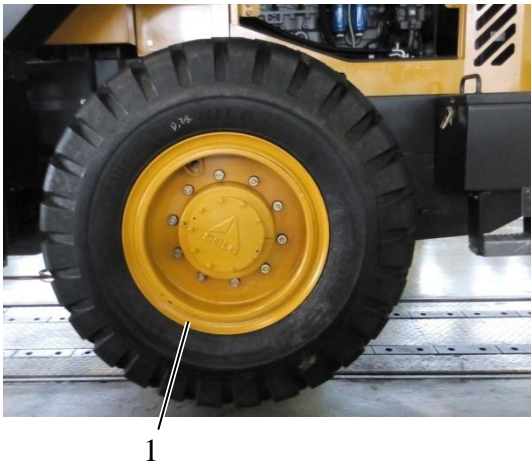

Fig. 4-78
1 Tire

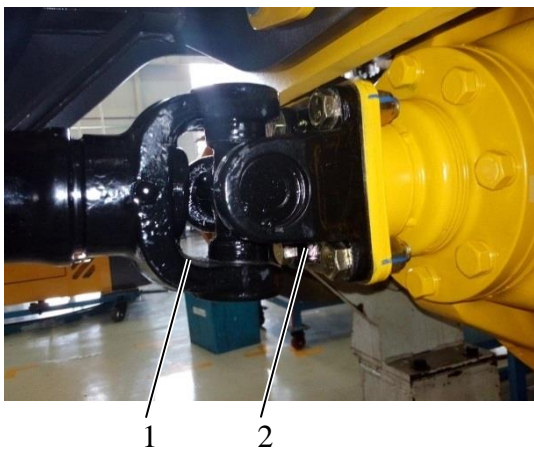

Fig. 4-79
1 Rear transmission shaft
2 Hexagon bolt

2. Disconnect the connection between the rear transmission shaft and the rear drive axle.



1

Fig. 4-80
1 Brake oil hose

3. Disconnect the T-junction brake oil hose from the rear drive axle.

★ATTENTION

Put a vessel under the axle to contain the hydraulic oil. Take proper measures to protect the removed joints.



1

Fig. 4-81
1 Rear drive axle

4. Hang the rear drive axle with the lifting appliance, and the tightness of hoisting rope should be moderate.

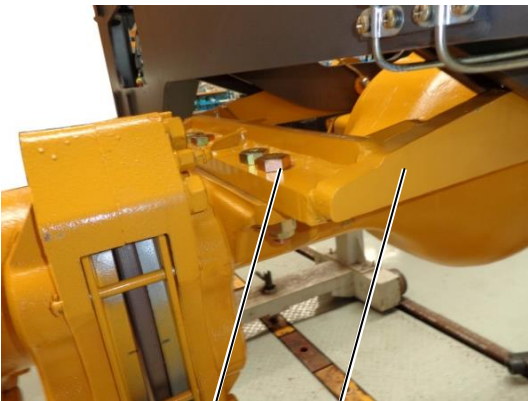

1

2

Fig. 4-82
1 Connecting bolt
2 Auxiliary frame

5. Remove the connecting bolts between the auxiliary frame and the rear drive axle.
6. Operating the lifting appliance to keep the rear drive axle level and put it down slowly.



Fig. 4-83
1 Rear drive axle

Assembly rear drive axle

1. Hang and put the assembled axle on a trolley, and push the trolley under the frame.
2. Hang the rear axle to the suitable position with the lifting appliance.

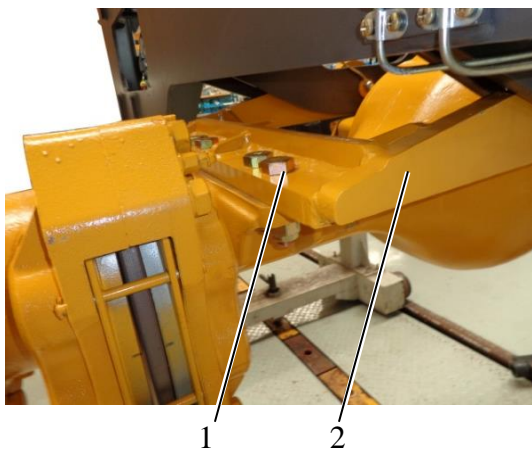

Fig. 4-84
1 Connecting bolt
2 Auxiliary frame

3. Connect the rear drive axle to auxiliary frame with bolts and tighten the bolts repeatedly and diagonally.

 Nm 450±50Nm

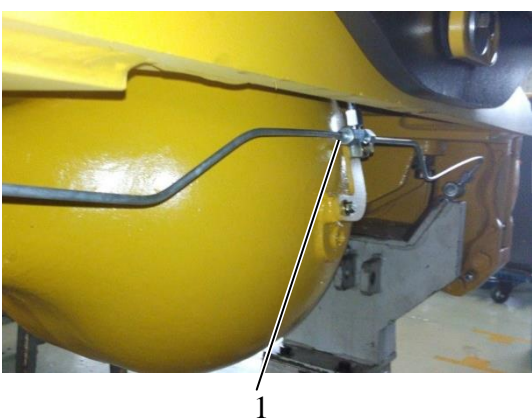

Fig. 4-85
1 Brake oil hose

4. Connect the T-junction brake oil hose to the rear drive axle.

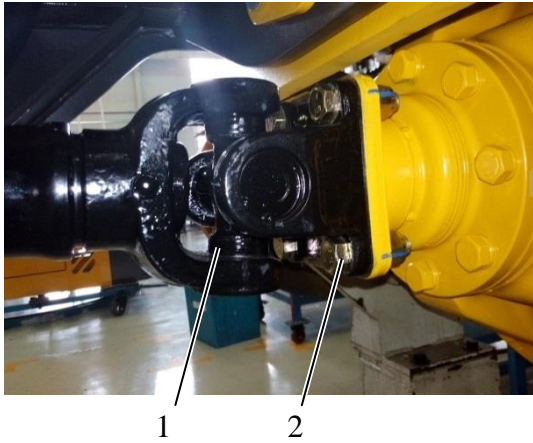

Fig. 4-86
 1 Rear transmission shaft
 2 Hexagon bolt

5. Connect the rear drive axle to rear transmission shaft assembly.

★ATTENTION

Align the orientation arrow of the two transmission shafts.

 Nm 145±20Nm



Fig. 4-87
 1 Tire

6. Install the rear wheels.
 Refer to **7 Frames, Tire & Working Device**.
7. Put down the machine slowly.

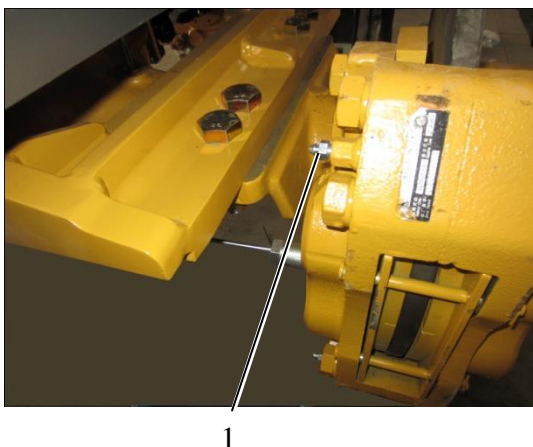

Fig. 4-88
 1 Deflating valve

8. Deflate the brake system.
 Refer to **5 Brake System**.

Disassembly of front drive axle

1. Remove the two front wheels.

Refer to **7 Frames, Tire & Working Device**.



Fig. 4-89
1 Tire

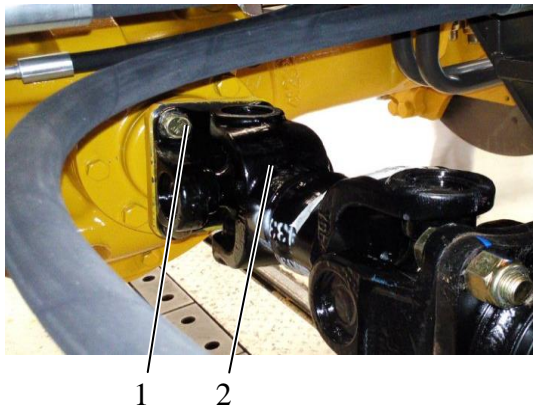

Fig. 4-90
1 Hexagon bolt
2 Front transmission shaft

2. Disconnect the connection between the front transmission shaft and the front drive axle.

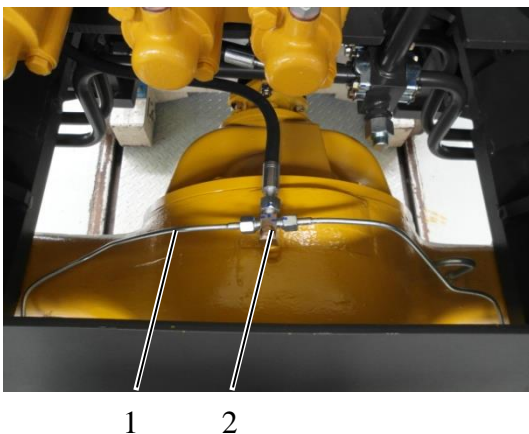
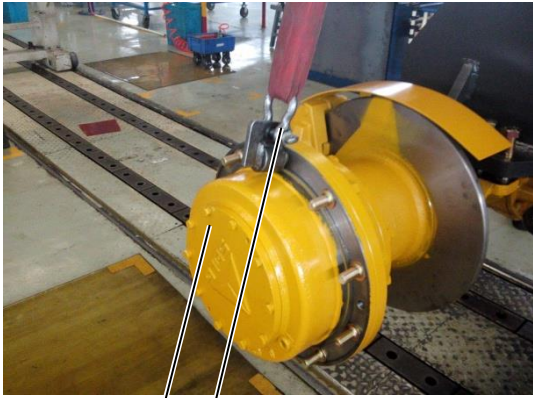

Fig. 4-91
1 Brake oil hose
2 Nut

3. Disconnect the T-junction brake oil hose from front drive axle.

★ ATTENTION

Put a vessel under the axle to contain the hydraulic oil. Take proper measures to protect the removed joints.



1 2

Fig. 4-92

- 1 Front drive axle
- 2 Lifting rope

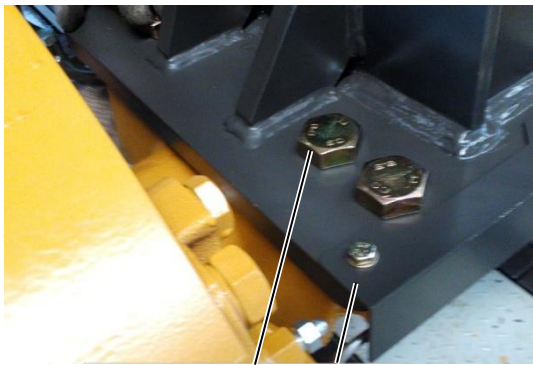

1 2

Fig. 4-93

- 1 Bolt
- 2 Front frame



1 2

Fig. 4-94

- 1 Front drive axle
- 2 Lifting rope

4. Hang the front drive axle with the lifting appliance, and the tightness of hoisting rope should be moderate.

5. Remove the connecting bolts between the front frame and the front drive axle.
6. Operating the lifting appliance to keep the front drive axle level and put it down slowly.

Assembly front drive axle

1. Hang and put the assembled axle on a trolley, and push the trolley under the frame.
2. Hang the front axle to the suitable position with the lifting appliance.

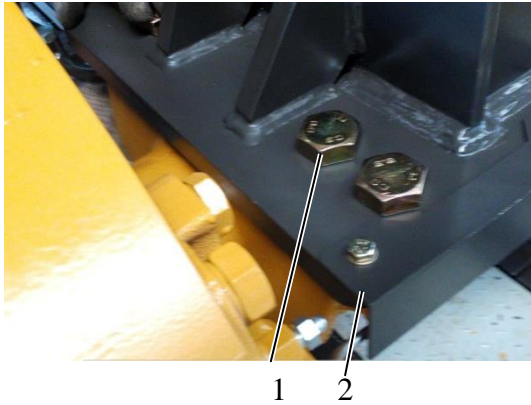

Fig. 4-95
1 Bolt
2 Front frame

3. Connect the front drive axle to front frame with bolts.

 Nm 450±50Nm

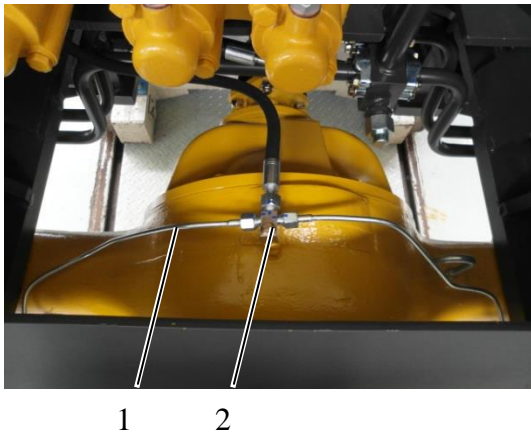

Fig. 4-96
1 Brake oil hose
2 Nut

4. Connect the T-junction brake oil hose of front drive axle.

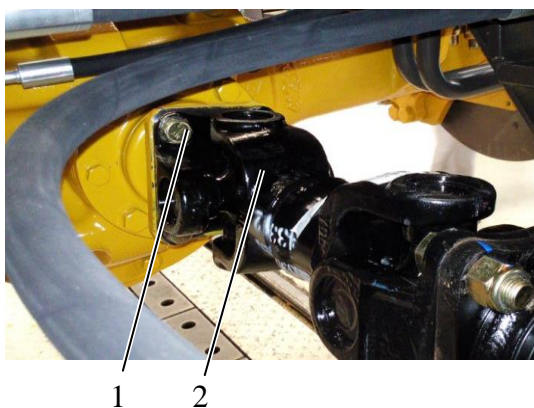



Fig. 4-97
1 Hexagon bolt
2 Front transmission shaft

5. Connect the front drive axle to front transmission shaft assembly.

★ATTENTION

Align the orientation arrow of the two transmission shafts.

 Nm 145±20Nm



1

Fig. 4-98

1 Tire

6. Install the front wheels.
Refer to **7 Frames, Tire & Working Device.**
7. Put down the machine slowly.

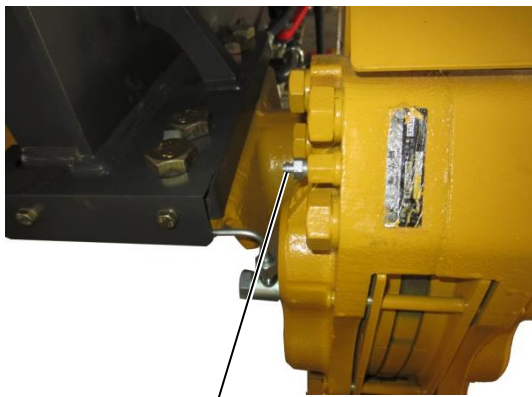

1

Fig. 4-99

1 Deflating valve

8. Deflate the brake system.
Refer to **5 Brake System.**

44 Diagnosis and Solutions for Common Faults of Transmission System

441 Fault Diagnosis and Solutions for Transmission box

1. Causes of gear shifting clutch faults

In the transmission box, the clutch is a vulnerable part. Operate to engage the clutch, the hydraulic pressure overcomes the spring force to force the piston to move and pull-in friction disc and steel disc. And with the increase of the hydraulic pressure, the pressing force increases.

Each time you shift a gear, friction phenomenon will happen between friction disc and steel disc, although in the design process we have considered using cooling fluid to discharge friction heat, the cooling effect is limited. As the discs thinning, the clutch requires more hydraulic oil to generate enough pressing force, at this time we must further accelerate the diesel engine.

When speed up the engine to high idle speed, sliding engagement time between the friction disc and steel disc will be lengthened, and the generated friction heat will be more. If hydraulic oil is heated to high temperature enough to change the sealing performance of the transmission box, the transmission box will produce internal leakage. And the internal leakage results in heat increase in two ways:

- a. When high pressure oil flows through the sealing leakage area there will be friction, which makes the oil temperature rise continuously;
- b. Oil leakage will reduce the oil flow in the system, in order to fully engage the clutch, hydraulic pump have to supply more oil to generate enough pressing force. That is, the engine needs to be re-accelerated to make the pump output more oil. This is a vicious circle, eventually leads to the clutch overheating or burnt, till completely ineffective.

2. Common fault diagnosis and solutions for transmission box and its oil system.

- a. Couldn't shift a gear

Fault causes: Inaccurate shifting position; leakage of clutch piston; low shifting oil pressure; blockage of oil gallery in transmission box.

Solutions: Re-engage the gear or check the transmission control valve; overhaul and replace the seal ring; Refer to **Fault b** for troubleshooting of low shifting oil pressure fault.

- b. The shifting oil pressure is low

Fault analysis: Improper adjustment of the main pressure regulating valve or the spring is broken to lose efficacy; the oil level of the transmission box is too low; the filter screen and the oil passage is blocked; the clutch leaks; gear shifting pump loses efficacy.

Solutions: Re-adjust or change the spring; fill oil to specified level; clean or dredge; repair or replace the seal ring.

c. Oil temperature is too high

Fault analysis: Operating time is too long; the oil is insufficient or overmuch; the clutch discs sliding; the clutch couldn't be disengaged.

Solutions: Stop the loader or idle running for a period of time; fill oil to overflow; check the oil pressure and seal ring; check the clutch control oil passage or the position of operating handle.

d. Shifting oil pressure of a certain gear is low

Fault analysis: Damaged piston or seal ring of this gear; blockage or leakage of oil passage.

Solutions: Replace the seal ring; Check, clean and eliminate the problem.

e. Disordered gears

Fault analysis: Leakage of the shaft end seal ring

Solutions: Replace the seal ring.

f. System leakage

Fault analysis: Loose pipe joints; damaged seal ring.

Solutions: Tighten the joints; replace the seal ring.

g. The oil level of transmission box oil sump automatically rises

The reason for this phenomenon is that steering pump or working pump input shaft seal is damaged, the oil of the hydraulic system flows through the torque converter gearbox to the transmission box sump, leading to oil level rise. Replace the oil seal if necessary.

442 Fault Diagnosis and Solutions for Drive Axle

1. Drive axle produces abnormal sound

a. The phenomena and its harm

The abnormal sound manifest in various forms: some sound continuously, some sound intermittently; some sound when the speed changes, some sound when normal driving; some sound when uphill, some sound when downhill; some sound dreary, some sound crisp.

The sound of drive axle is mostly from the main transmission and differential, some also occur in wheel reducer.

The drive axle's abnormal sound is an abnormal reflection of technical state between the drive axle parts. If there is abnormal sound problem, the user should promptly identify the causes and eliminate them, or it may cause bigger troubles even accidents.

b. The causes for drive axle abnormal sound and solutions

The cause of the drive axle sound is almost due to the collision or interference generated by some parts in the rear axle (including the wheel reducer).

Due to different parts in different states produce the sound with different intensity and characteristic, you can base on the abnormal sound producing conditions and parts to estimate the sound source and find out the sound reason.

- One reason is that the noise is produced by the loose connections and damaged parts, and this kind of sound is much belong to the abnormal friction and collision between the parts, so the sound is clear;
- The other is that the noise is produced by the abnormality of the bearing fit and gear engagement.
- The abnormality of the gear engagement is that meshing clearance is too small or too large, meshing position is not correct, meshing area is insufficient. At this time the gear can produce continuous and clear sound, which increasing with the increase of rotational speed. The abnormality of the bearing fit is that bearing clearance is too large or too small. When the clearance is too large, the bearings can produce continuous sound, which increasing with the increase of the speed.
- When the rear axle housing produces sound, in addition to checking whether the parts loose or not, you should first check whether the meshing area of the main transmission bevel gear is correct or not.

2. Drive axle is overheating

a. The phenomena and its harm

The drive axle overheating is that after the drive axle mechanically works a period of time, its temperature exceeds the permissible normal temperature range. Generally speaking, when checking by hand touch, you will have a hot feeling. The overheating mainly produces in the place of drive axle housing (except the main drive and differential) and wheel reducer. The drive axle overheating is the same as the abnormal reflection of technical state of the drive axle parts, or cooperative relationship, or lubrication. You should promptly identify the reasons and eliminate them, in order to avoid damaging the relevant parts.

b. The causes for drive axle overheating fault and solutions

- Causes: produce more heat; the heat can't be dissipated in time.
- The heat source of the wheel drive axle mainly is friction heat, and that the friction heat can only be caused by the too small fit clearance of the relative motion parts. The matching parts of the drive axle have two categories: one is the bearing, the other is the gear. So the fundamental cause of the overheating drive axle is too small clearance of bearing fit or of gear engagement.

- The main reason for heat dissipation problem of the drive axle is that the drive axle (and the wheel reducer) is lack of lubricating oil or the oil is inferior oil. Lack of lubricating oil or inferior oil not only makes the friction heat generated by the drive axle cannot be dissipated in time, but also can make the relative movement parts are in a dry friction state, which makes the friction heat increase greatly.
- When the drive axle is overheating, we can base on the overheating position to determine the causes of overheating. If the bearing is overheating, we can ascertain that the fault is caused by the bearing; when the whole drive axle housing is overheating, the reason may be caused by the abnormal gear engagement or lubricating oil shortage; you should fill the specific lubricants timely.

3. Oil leakage of drive axle

a. The phenomena and its harm

The oil leakage of the drive axle occurs mostly in the axle housing and wheel reducer, and mostly leaking through the seal and the fitting surface.

b. The causes for oil leakage of drive axle and solutions

- The oil leakage of the drive axle mainly is caused by the damaged sealing elements and sealing gaskets, for the former: such as the oil leakage caused by damaged final drive's oil sealing; for the latter: such as the oil leakage of the rear axle housing and wheel reducer fitting surface.
- Check the whether oil sealing is aged, cracked or damaged or not; don't widen the oil seal too fiercely, to avoid the plastic deformation; try to warm the oil sealing with liquid that has the same temperature as operating temperature, and then install it with special tools.



Service Manual

LG936L

Version:0510



5 Brakes



CONTENTS

5	Brake System.....	5-1
51	Service Brake System.....	5-1
511	Composition and Working Principle of Service Brake System.....	5-1
512	Introduction of Main Components	5-3
513	Air Bleeding Method of Brake System	5-12
514	Disassembly and Assembly of Main Components.....	5-13
52	Parking Brake System	5-23
521	Components and Working Principle of Parking Brake System	5-23
522	Disassembly and Assembly of Main Components.....	5-24
53	Brake System Common Faults and Troubleshooting.....	5-27

5 Brake System

51 Service Brake System

The service brake is a set of brake system triggered by foot brake valve which is operated by the driver to realize speed reduction and stop when the vehicle is running.

511 Composition and Working Principle of Service Brake System

The brake of this road roller is air-over-oil dry-type disc brake, which mainly consists of air compressor, oil-water separator combination valve, booster pump, brake caliper, gasholder and pipeline.

Air is absorbed in through engine filter and compressed in air compressor, then goes into gasholder through oil-water separator. When the driver stomps the brake pedal, compressed air will flow into booster pump from gasholder, to push brake oil in booster pump oil cup, and pressure oil will flow into brake oil pipe to engage brake by pushing brake caliper.

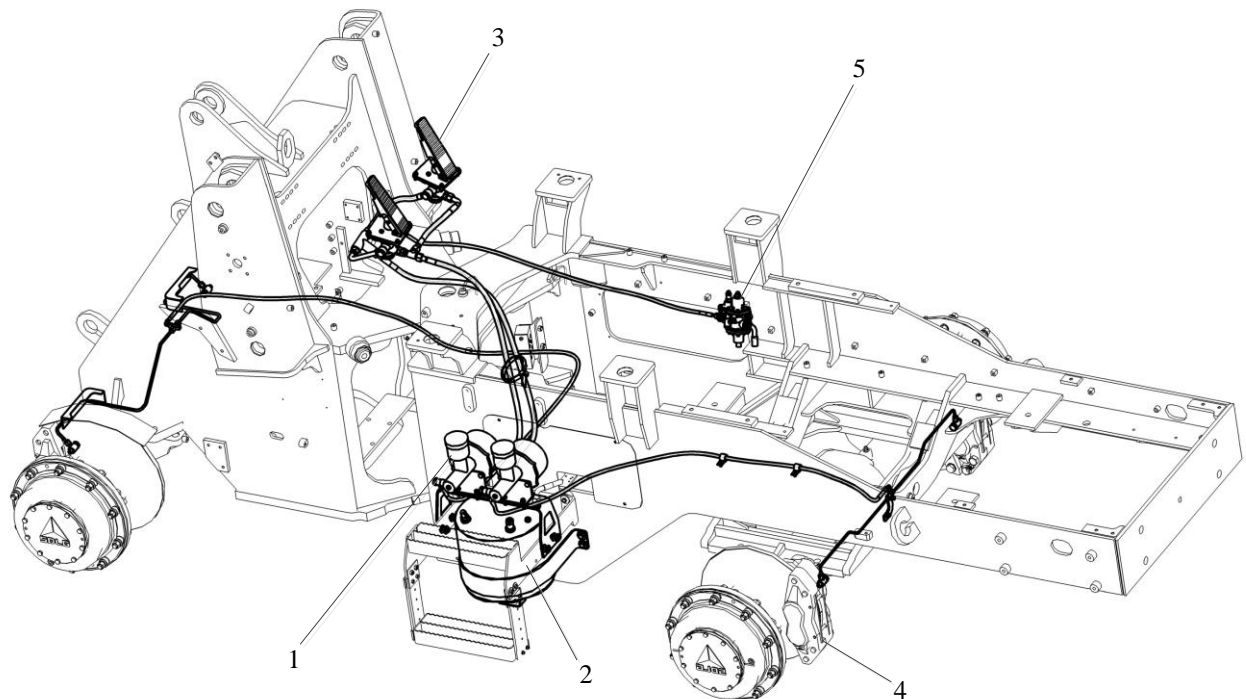

Fig. 5-1 Main components of service brake system

1 Booster pump

2 Gasholder

3 Foot brake valve

4 Brake caliper

5 Oil-water separator

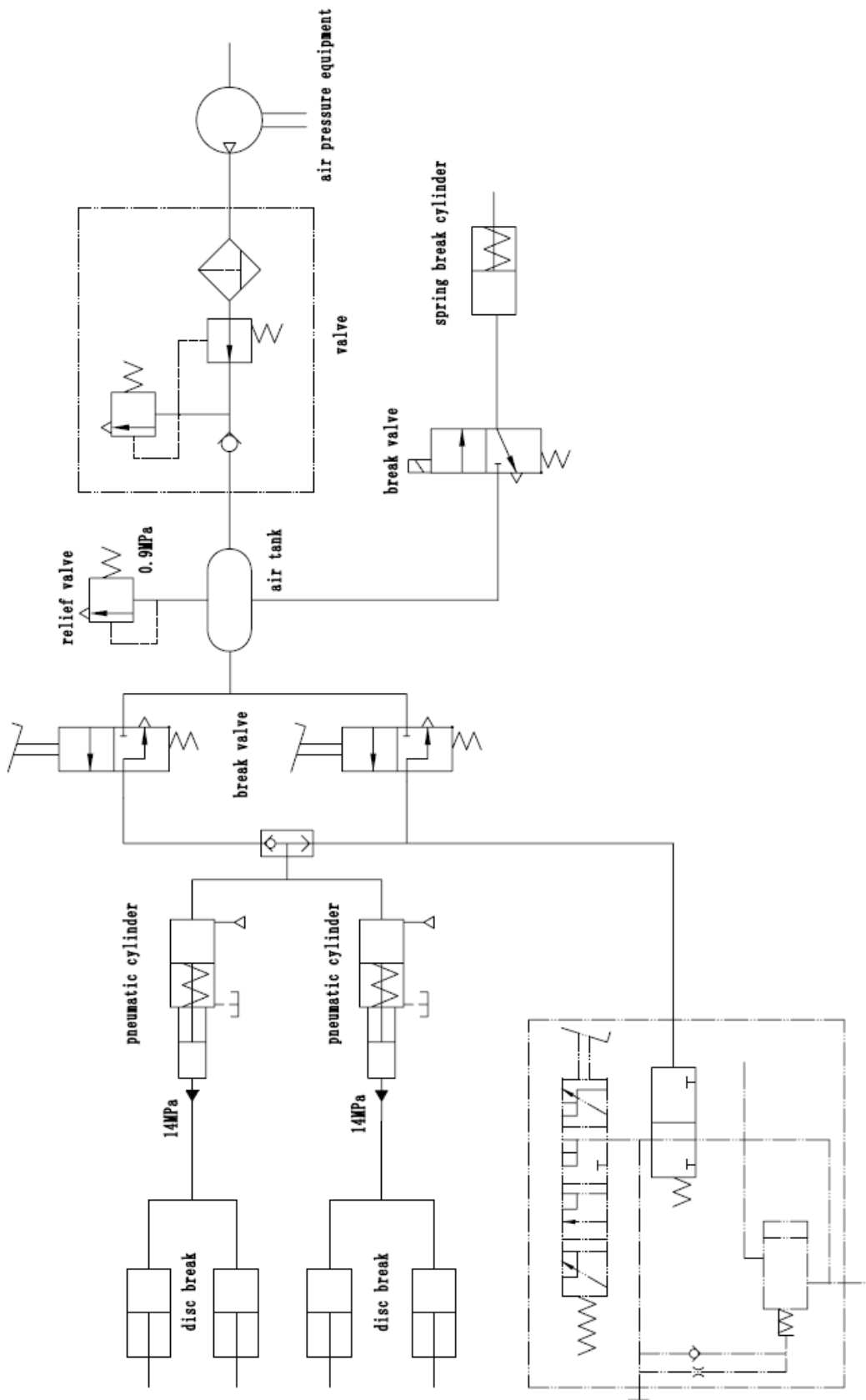

Fig. 5-2 Brake System principle diagram



Fig. 5-3
1 Oil-water separator combination valve

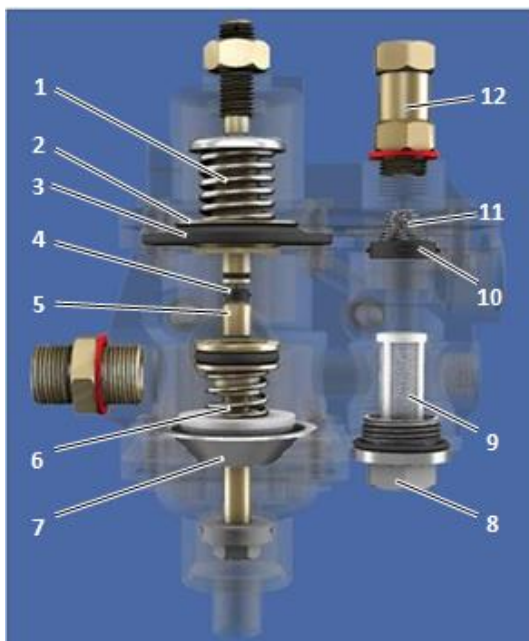

Fig. 5-4 Construction of oil-water separator

512 Introduction of Main Components

Oil-water separator combination valve

1. Function

The oil-water separator combination valve is a valve combined by oil-water separator and pressure regulator, and its functions are:

- 1) Automatically regulate working pressure of air source of the brake system to ensure safety of road roller brake system;
- 2) Separate impurities such as oil and water from compressed air, and discharge them automatically via unloading unit;
- 3) Inflate the tire after the wing nut is loosened and removed.

2. Structural composition

The pressure regulator of oil-water separator combination valve consists of control piston, control valve, adjusting spring and drum membrane;

Air-liquid drain valve mainly consists of air bleeding piston assembly, oil collector and valve seat;

- | | |
|---------------------------|-------------------|
| 1 Adjusting spring | 2 Control piston |
| 3 Drum membrane | 4 Adjusting valve |
| 5 Valve seat | 6 Return spring |
| 7 Oil collector | 8 Plug screw |
| 9 Filter element assembly | 10 Check valve |
| 11 Spring | |
| 12 Safety valve assembly | |

Fig. 5-5

1 Pressure regulating screw

2 Safety valve assembly

3 Wing nut

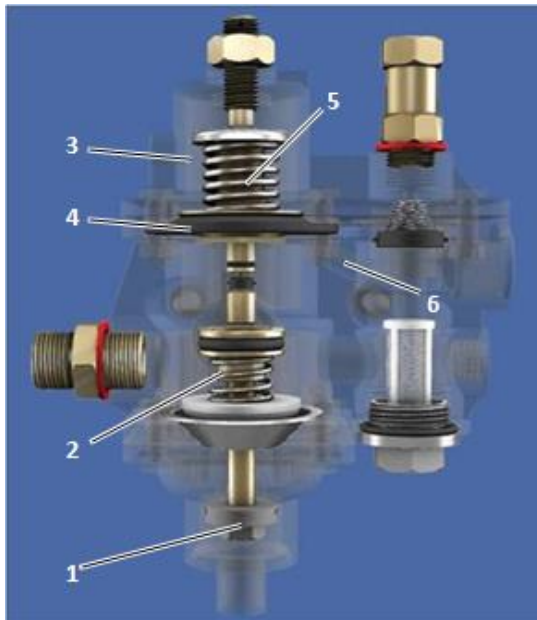
Fig. 5-6 Structure of oil-water separator

3. Precautions during operation

The key parts such as pressure regulating screw and safety valve assembly have been adjusted by the manufacturer before delivery; thus normally, it is forbidden to do adjustment without authorization to avoid damaging to the whole brake system and endangering traffic safety; if adjustment is required indeed, it shall be done according to the adjusting order: firstly adjust safety valve assembly and then the pressure regulating screw so as to ensure the pressure in the system is not too high after adjustment; remove the wing nut (as shown in the figure), connect the inflation air pipe, and the filtered compressed air can be used to inflate tires.

4. Common faults

1. If the seal ring of drain valve at the bottom of exhaust piston is damaged or gets seized by debris, it will lead to lax close the of the valve and directly result in air leakage;
2. If the return spring of air bleeding piston is in failure or the air bleeding piston is seized, it will lead to lax close the of the valve and directly result in air leakage;
3. If the vent hole on upper housing is blocked, the air bleeding piston will not effectively return, and it will lead to lax close the of the valve and directly result in air leakage;
4. If drum membrane is broken, it will lead to low pressure, and the compressed air will leak from the upper cover air vent;
5. After long period service, the pressure regulating spring force will decrease, which

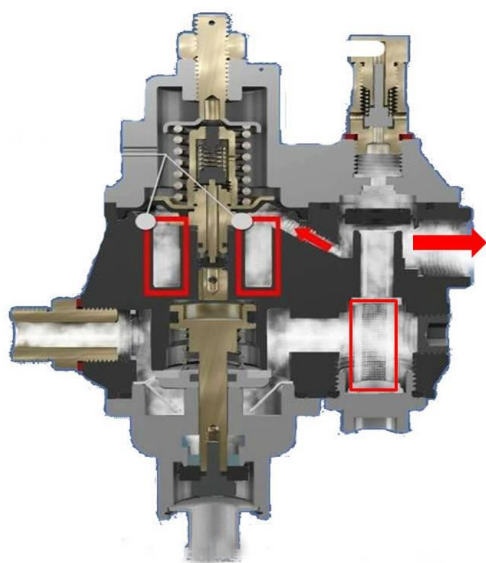

Fig. 5-7 Structure of oil-water separator

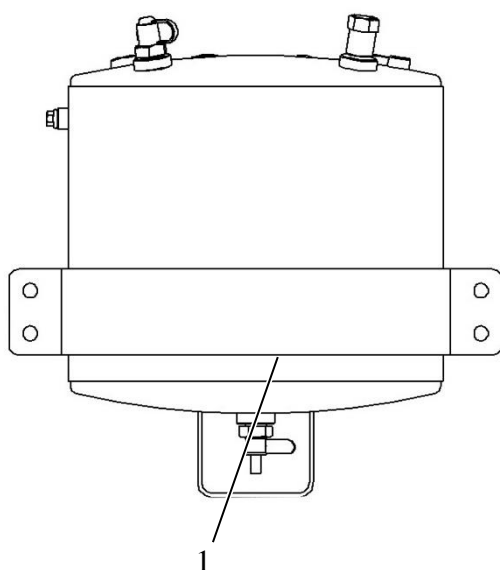

Fig. 5-8
1 Gasholder

will lead to low system pressure;

6. If the orifice that connecting chamber C and chamber D is blocked, and the pressure regulating spring and the piston assembly are jammed, pressure regulating function will be partially disabled; in this case, when the air pressure exceeds 0.784MPa, compressed air will act on and open the safety valve, and discharged to atmosphere.

Gasholder

1. Function

The gasholder is equipped on the tail of rear frame (under left platform), and it is mainly used for:

- 1) Storing compressed air, and providing air for the brake system;
- 2) Ensuring air consumption for certain times of braking when the air compressor does not work;
- 3) Functioning as a carrier for installation of safety valve, air pressure sensor and water drain valve;
- 4) Realizing service braking when the driver depresses the brake pedal (compressed air flows into brake or working chamber via control valve);

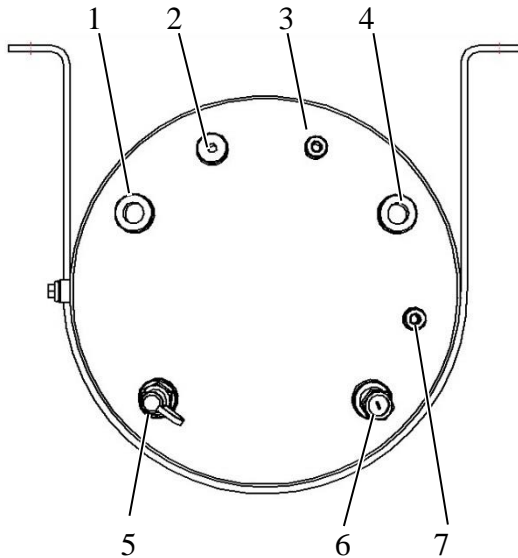

Fig. 5-9

- 1 Foot brake valve joint
- 2 Pressure sensor
- 3 Emergency brake pressure switch joint
- 4 Oil-water separator combination valve joint
- 5 Tire inflation valve
- 6 Safety valve
- 7 Brake magnetic valve splice

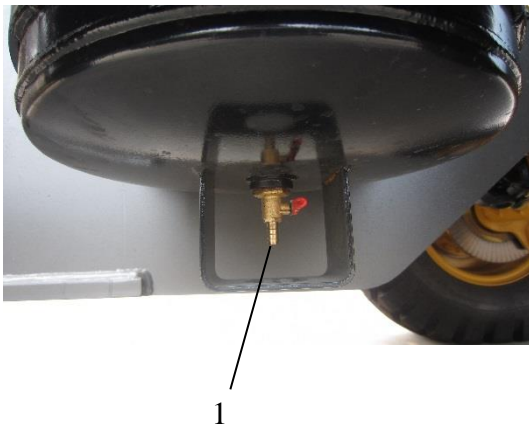

Fig. 5-10

- 1 Water drain valve

2. Structure

1) Foot brake valve joint

When foot brake valve opens, compressed air outflows from gasholder.

2) Pressure sensor

It is used provide pressure data for air pressure gauge, which enable the operator to correctly determine the brake status and whether the air pipeline is in good condition.

3) Emergency brake pressure switch joint

4) Oil-water separator combination valve joint

The compressed air, primarily separated from oil and water by the oil-water separator combination valve, enters into the gasholder.

5) Tire inflation valve

6) Safety valve

It is used for providing protection to the brake system in case that the safety control valve of oil-water separator combination valve is in failure; the set pressure is 0.85~0.9MPa, and when the air pressure is beyond this range, the safety valve will open to discharge.

7) Brake magnetic valve joint

3. Operation and maintenance

Cause of water accumulation in gasholder

When the air compressor delivers air to the gasholder, vapor may be generated because of temperature difference between inside and outside, and vapor will form drops and accumulated on the bottom of gasholder.

Risks from water accumulation in gasholder

When water accumulated to a certain extent and not being discharged timely, water, rust and

impurities will enter into the foot brake valve and booster pump via pipeline and contaminate them when brake is applied, which will lead to faults, such as lubricating performance degradation, rust, seal wear and piston seizure.

★ ATTENTION

Water accumulation in the gasholder is one of primary reasons which lead to brake component failure, thus customer should comply with the requirements in Operating and Maintenance Manual and drain water timely.

Foot brake valve assembly

This loader adopts double brake pedal, the left one has function of power cut-off.

1. Function

The foot brake valve is used to control compressed air flow to booster pump air chamber when brake is engaged, i.e., to control the air pressure in booster pump, thereby different braking effects can be realized, and to provide driver with “Road Sense” when braking is engaged, i.e., be able to sense the machine condition and engage the pedal accordingly (stroke and force).

The foot brake valve is controlled by brake pedal to engage or relive brake.

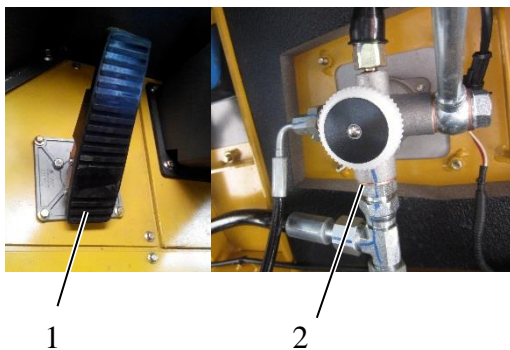

Fig. 5-11
 1 Foot brake pedal
 2 Foot brake valve

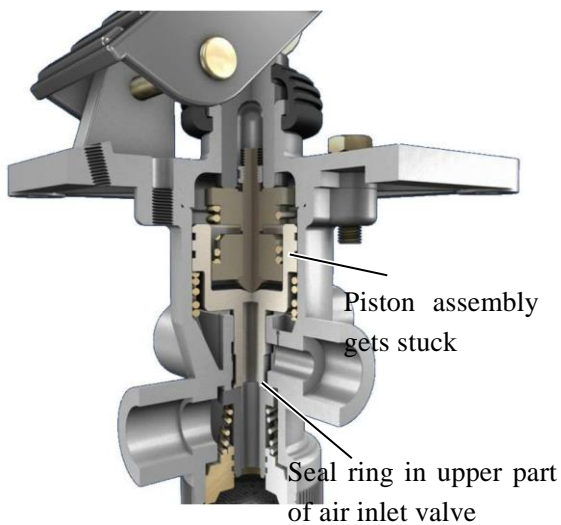

Fig. 5-12 Structure of foot brake valve

2. Common faults

1) Braking torque decreases

Causes analysis:

The piston assembly gets stuck and fails to push down air inlet valve element to open air inlet effectively;

The seal ring in upper part of air inlet valve is damaged or has debris, and some air leaks out from air inlet valve;

2) Braking lag

Cause analysis:

The valve element gets stuck or broken.

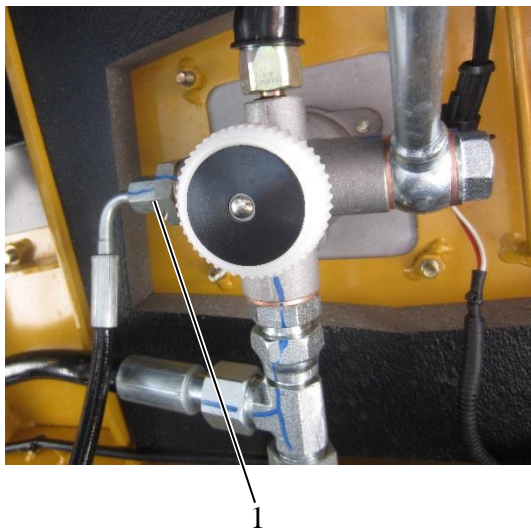

Fig 5-13
1 Power cut-off—foot brake valve pipe

3. Power cut-off

Stomp foot brake valve and foot brake valve will open, compressed air form gasholder acts on transmission control valve to neutralize the transmission box, output power is cut off.

★ATTENTION

When operating or driving on flat ground, power cut-off function can be used to reduce the load on the brake and transmission. However, you cannot use power-off function when operating on slope to avoid sliding, in order to ensure traffic safety.

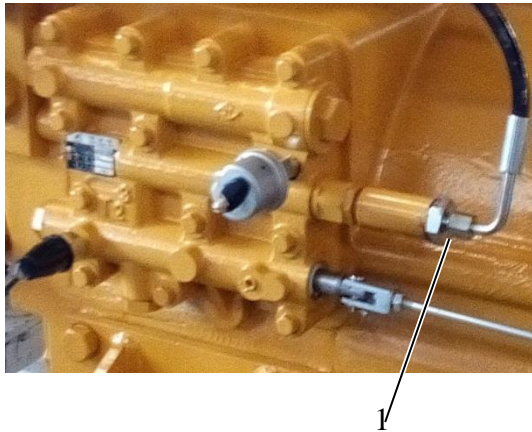

Fig 5-14
1 Power cut-off—transmission control valve pipe

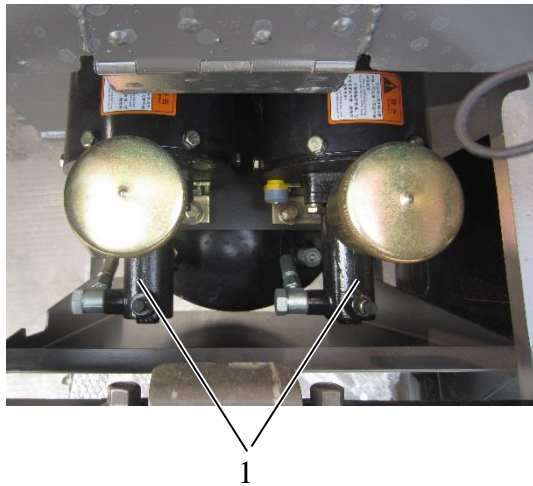

Fig. 5-15
1 Booster pump

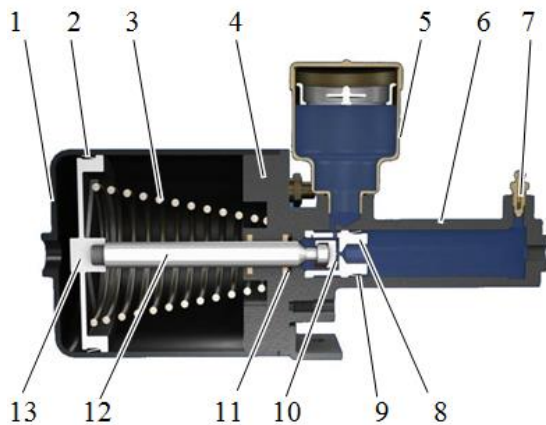

Fig. 5-16

The loader applies double brake pedal, only the left one has power cut-off function. Thus when driving or working on the slope, please use the right brake pedal to brake.

Booster pump

1. Function

The loader is equipped with a single booster pump installed on front frame.

The function of booster pump is utilizing the compressed air from brake valve to pressurize the brake fluid in brake pump cylinder and then the pressurized fluid will push the brake caliper piston of rear drive axle to work so that loader braking is realized.

2. Structure

The booster pump mainly consists of booster pump cylinder block, brake pump cylinder block, oil pressure piston, brake piston, pushrod, end cover, return spring, oil cup and seals.

- | | |
|-------------------------------|-------------------------------|
| 1 Booster pump cylinder block | 2 Seal ring |
| 3 Return spring | 4 End cover |
| 5 Oil cup | 6 Brake pump cylinder block |
| 7 Air bleeding screw | 8 Oil pressure piston |
| 9 Seal ring | 10 Master cylinder rubber cup |
| 11 Seal ring | 12 Push rod |
| 13 Brake piston | |

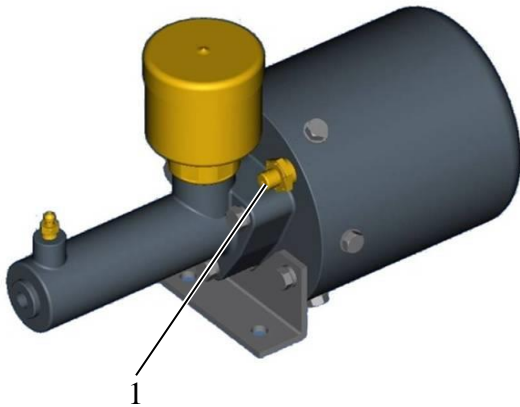

Fig. 5-17
1 Breather

The breather is installed on the end cover of booster pump. Through the breather, the spring chamber of booster pump cylinder is connected to atmosphere. When braking is applied, compressed air acts on cylinder piston and pushes it forward, and the spring chamber of air cylinder discharges air to make the piston move quickly; when braking is released, air fills the spring chamber through the breather, piston returns under the effect of spring force, and braking is relieved.

The breather has a screen to filter impurities in air. The breather should be replaced regularly during operation so as to prevent it from being blocked which will lead to poor braking performance. The entry of impurities due to damaged breather will damage the booster pump.

3. Common faults

Internal leakage: Park the road roller on flat ground and engage neutral gear. As air pressure reaches the specified value, depress the brake pedal and do not release, and if the seals of cylinder block of booster pump leak seriously, air will come out from the booster pump breather obviously, and observe the brake fluid in the oil cup at this time, you will find obvious ripple phenomenon or bubbles coming out from the bottom of oil cup. Additionally, to judge if the seal ring at the center of booster pump leaks, you can check the joint of cylinder and end cover for brake fluid leakage.

External leakage: Based on analysis, the external oil leakage at the joint of oil cup and end cover or the joint of oil cylinder block and end cover is caused by looseness of booster pump seals;

Common leakage points are shown in Fig. 5-18.



Fig. 5-18



Fig. 5-19
 1 Brake caliper 2 Deflating valve
 3 Brake oil pipe

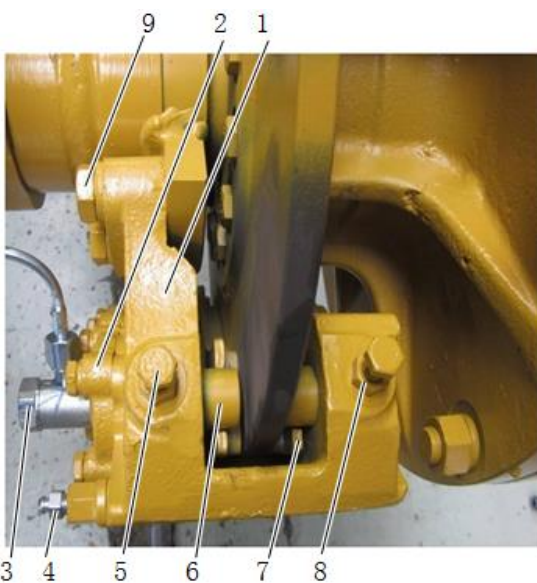

Fig. 5-20 Structure of brake caliper



Fig. 5-21 Working principle

Brake caliper

1. Function

The brake of LG936L loader is of caliper disc dry-type brake, of which by clamping the brake disc of drive axle from both sides to realize brake. The brake disc of drive axle, taken two end faces as working surfaces, are fixed and rotates with wheels.

Pressurized brake fluid acts on brake caliper piston and then push friction discs to clamp the rotating brake disc from both sides for braking.

2. Structure

The caliper disc type brake caliper applies unitary structure which has better strength and stiffness. Friction discs, which can slide along guiding shaft, are installed between brake disc and piston;

- | | |
|------------------------|-----------------------|
| 1 Unitary caliper body | 2 End cover of piston |
| 3 Hollow bolt | 4 Air bleeding screw |
| 5 Adjusting bolt | 6 Guiding shaft |
| 7 Friction disc | 8 Locknut |
| 9 Fixing bolt | |

It is required to remove the caliper as a whole during friction disc replacement. As for overhaul of piston, only its end cover needs to be removed.

3. Working principle

When braking is applied, high pressure brake fluid from booster pump flows to each cylinder via oil tube and external & internal caliper ducts to push the symmetrically arranged pistons move inward. The brake fluid pushes friction discs to clamp brake disc, which will reduce the rotating speed of wheel connected to the brake disc till it stops running.

513 Air Bleeding Method of Brake System

1. Fill up the oil cup of booster pump with brake fluid.
2. Loosen the air bleeding screw of booster pump till continuous fluid flows out, and then retighten the air bleeding screw.

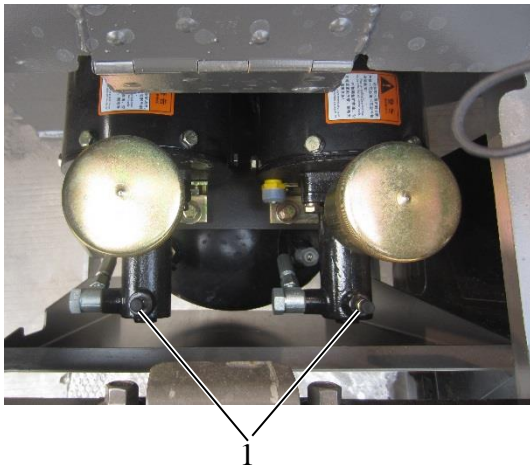

Fig. 5-22
1 Air bleeding screw

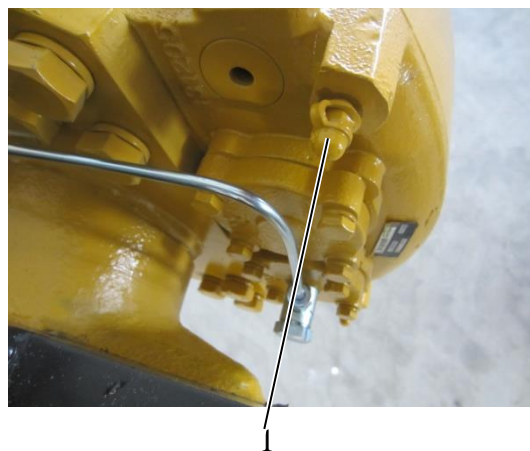

Fig. 5-23
1 Air bleeding screw

3. Start the engine, and when air pressure rises to specified value, depress the brake pedal for several times to make the brake pipe and the brake caliper filled with brake fluid. When the brake pedal is depressed, loosen the air bleeding screw of brake caliper for air bleeding and retighten it rapidly. Repeat the above procedures till there is no bubble coming out of brake caliper but continuous fluid flows out, stop air bleeding and tighten the air bleeding screw.
4. During air bleeding, continuously refill brake fluid to the brake oil cup so as to prevent air from entering again.
5. After air bleeding, add brake fluid to above 2/3 level of oil cup, and tighten the oil cup cover.

514 Disassembly and Assembly of Main Components

Disassembly of foot brake valve assembly

1. Switch on the drain valve of gasholder to unload the brake system.

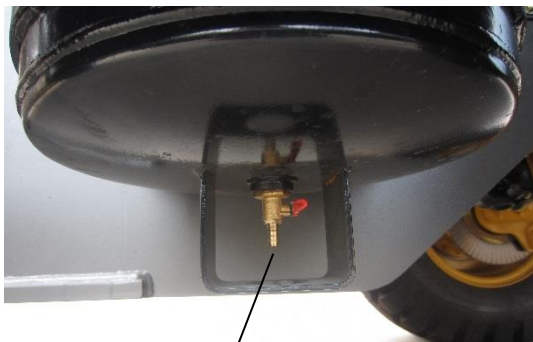

1

Fig. 5-24

1 Water drain valve



1 2 3 4

Fig. 5-25

1 Hose that connected to transmission control valve

2 Brake taillight pressure switch

3 Air outlet steel pipe 4 Air inlet hose

2. Disconnect the brake taillight pressure switch from foot brake valve, take down the switch.
3. Remove the hose that connected to transmission control valve, disconnect air inlet hose and air outlet steel pipe of left foot brake valve assembly

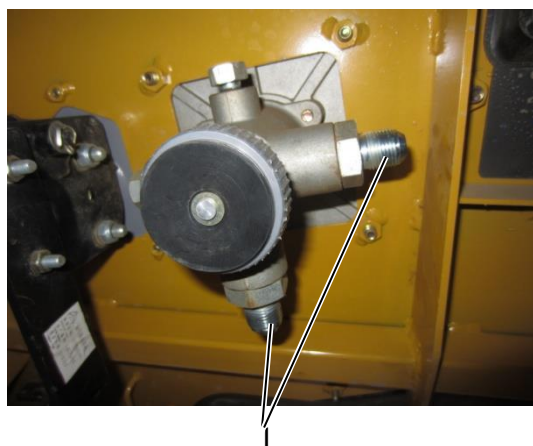

1

Fig. 5-26

1 Straight joint

4. Remove each straight joint.

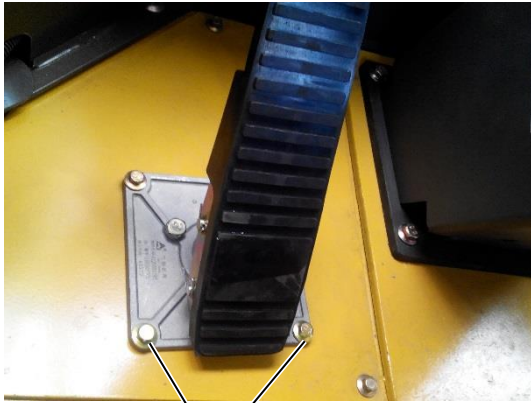

Fig. 5-27
1 Bolt



Fig. 5-28
1 Foot brake valve assembly

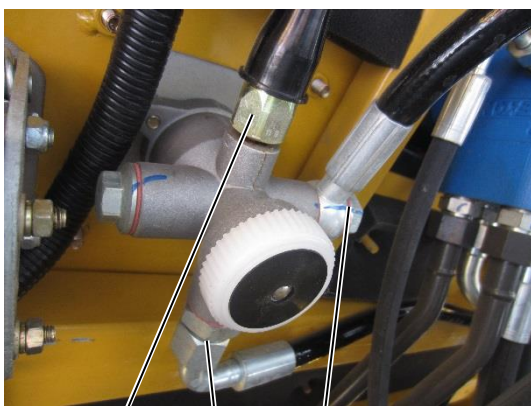

Fig. 5-29
1 Brake taillight pressure switch
2 Foot brake valve air inlet hose
3 Foot brake valve air outlet hose

5. Remove the four bolts that connecting foot brake valve assembly and cab.

6. Take foot brake valve assembly out from cab.

7. Loose the air inlet and outlet hoses of right foot brake valve assembly, disconnect brake taillight pressure switch.

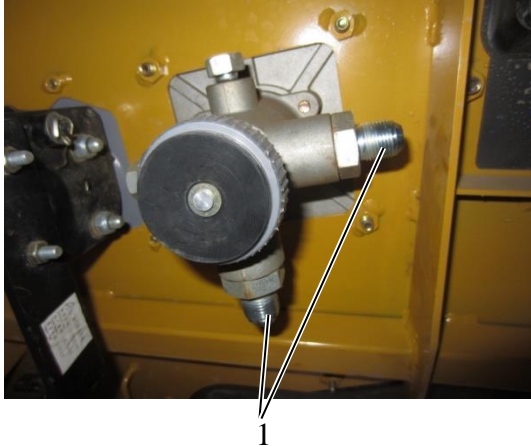

Fig. 5-30
1 Straight joint



Fig. 5-31
1 Bolt



Fig. 5-32
1 Foot brake valve assembly

8. Remove each straight joint.

9. Remove the four bolts that connecting right foot brake valve assembly and cab.

10. Take right foot brake valve assembly out from cab.

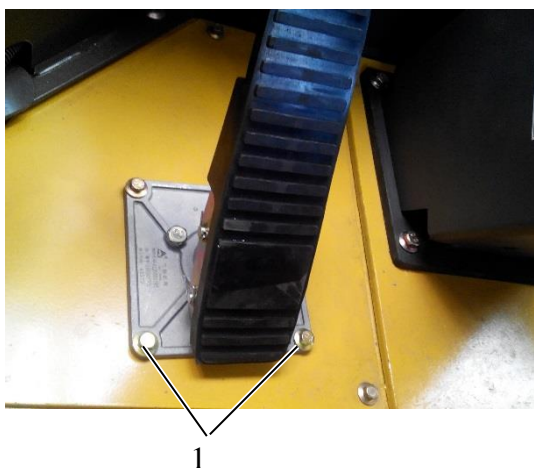

Fig. 5-33
1 Bolt

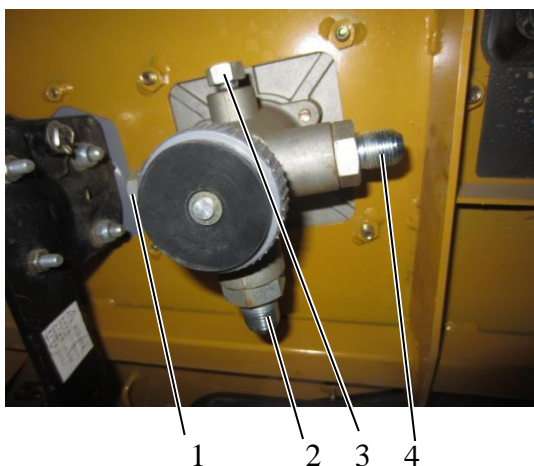

Fig. 5-34
1 Plug screw 2 Straight joint
3 Plug 4 Straight joint

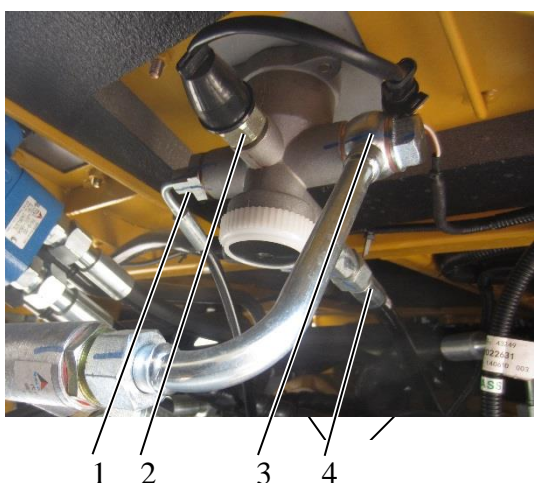

Fig. 5-35
1 Hose that connected to transmission control valve
2 Brake taillight pressure switch
3 Air outlet steel pipe 4 Air inlet hose

Assembly of foot brake valve assembly

1. Put left foot brake valve assembly into the cab, and tighten the four connecting bolts of foot brake valve and cab.

2. Install straight joints, plug screw and plug of foot brake valve assembly.

Apply proper amount of sealant on the ends of straight joints, plug screw and plug. Start sealant application from the second thread (count from the thread end) for 3~5 threads.

 AT545 Sealant

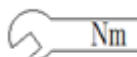
 Nm Straight joint: 70~90Nm

3. Connect air inlet hose and outlet steel pipe of left foot brake valve assembly, connect the hose that connected to transmission control valve, connect brake taillight pressure switch.



1

Fig. 5-36
1 Bolt

4. Put right foot brake valve assembly into the cab, and tighten the four fixing bolts.

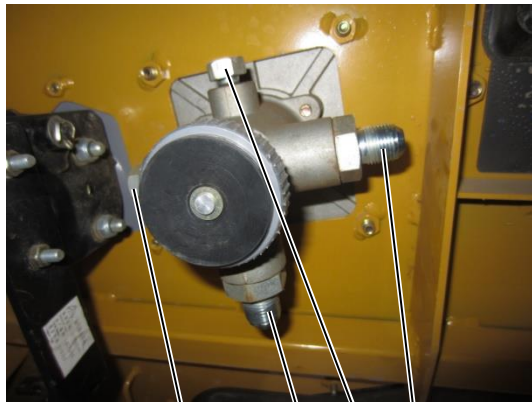

1 2 3 4

Fig. 5-37
1 Plug screw 2 Straight joint
2 Plug 4 Straight joint

5. Install the straight joints, plug screw and plug of foot brake valve assembly.

Apply proper amount of sealant on the ends of straight joints, plug screw and plug. Start sealant application from the second thread (count from the thread end) for 3~5 threads.

 AT545 Sealant

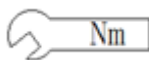
 Nm Straight joint: 70~90Nm

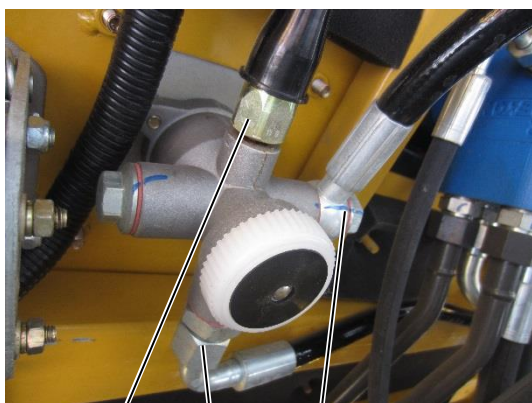

1 2 3

Fig. 5-38
1 Brake taillight pressure switch
2 Foot brake valve air inlet hose
3 Foot brake valve air outlet hose

6. Connect air inlet and outlet hoses of right foot brake valve assembly, connect brake taillight pressure switch.

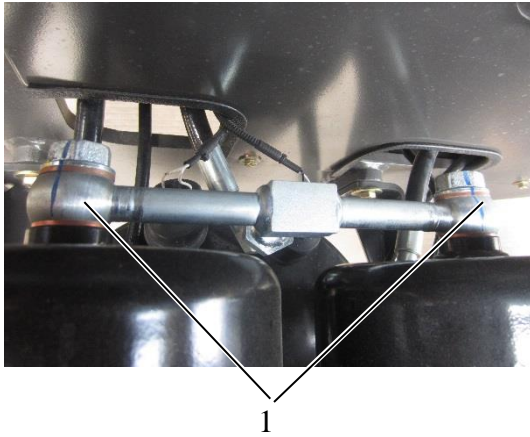

Fig. 5-39
1 Booster pump air inlet pipe

Disassembly of booster pump

1. Disconnect the two air inlet three-way steel pipes of booster pump.

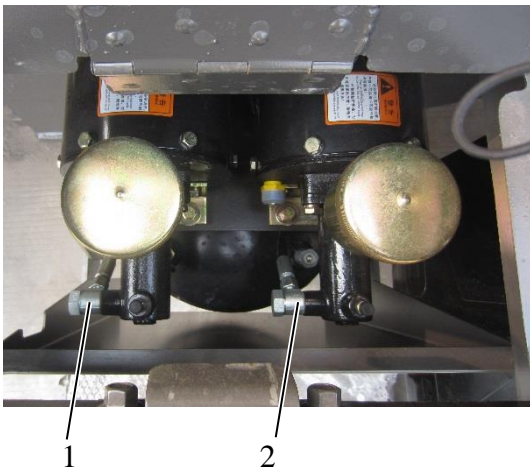

Fig. 5-40
1 To-front axle oil pipe
2 To-rear axle oil pipe

2. Disconnect to-front axle oil pipe of left booster pump and to-rear axle oil pipe of right booster pump respectively.

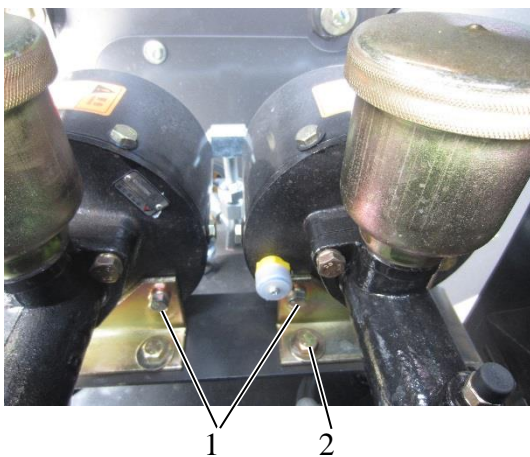

Fig. 5-41
1 Bolt that connecting booster pump and its support
2 Bolt that used to fix booster pump support on left platform

3. Loose the bolts that connecting booster pump and its support.

If needs to take down the booster pump and its support together, remove the bolts that used to fix booster pump support on left platform.

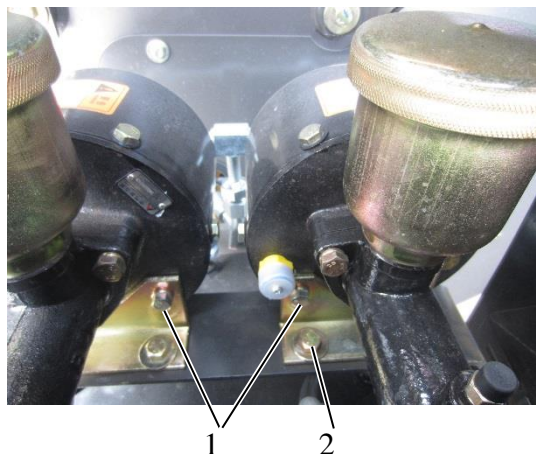

Fig. 5-42

1 Bolt that connecting booster pump and its support

2 Bolt that used to fix booster pump support on left platform

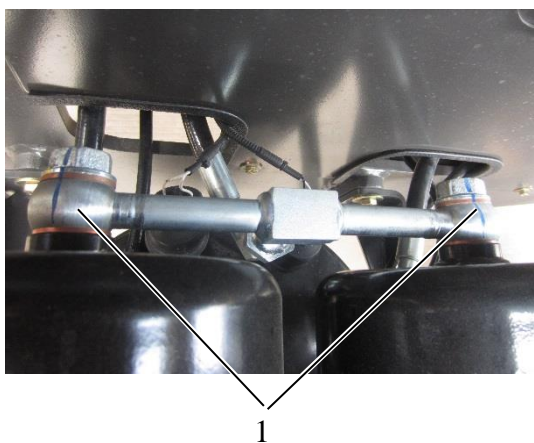

Fig. 5-43

1 Air inlet pipe of booster pump

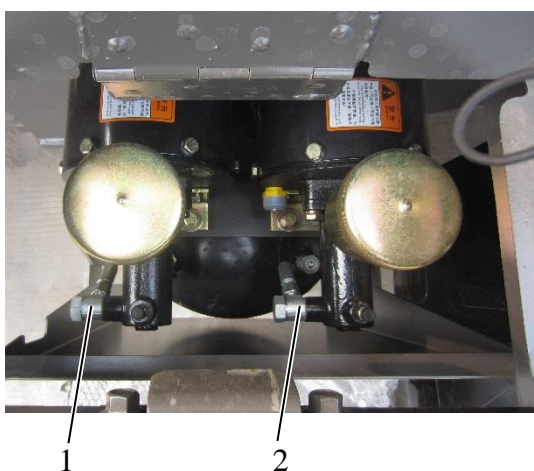

Fig. 5-44

1 To-front axle oil pipe

2 To-rear axle oil pipe

Assembly of booster pump

1. Install booster pump support on left platform with bolts, then install booster pump on the support.

2. Connect the two air inlet three-way steel pipes of booster pump.

3. Connect to-front axle oil pipe of left booster pump and to-rear axle oil pipe of right booster pump respectively.

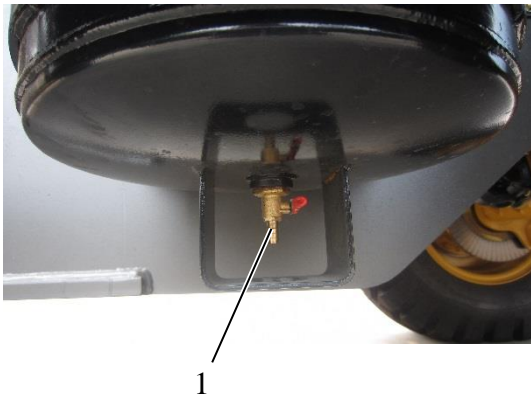

Fig. 5-45
1 Water drain valve

Disassembly of gasholder

1. Open the water drain valve of gasholder to unload the brake system.

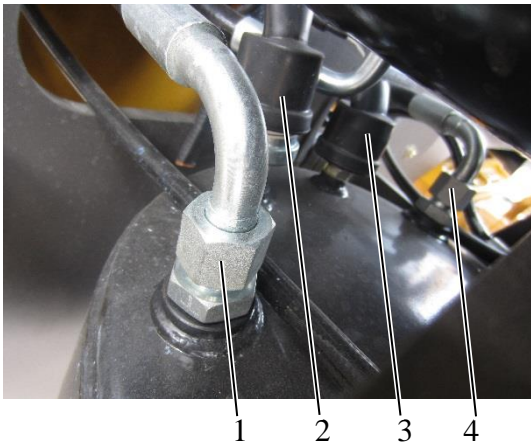

Fig. 5-46
1 Gasholder to foot brake valve hose
2 Pressure sensor
3 Emergency brake pressure switch
4 Gasholder to oil-water separator connection valve hose

2. Disconnect each connecting hose and sensor wiring harness of gasholder.

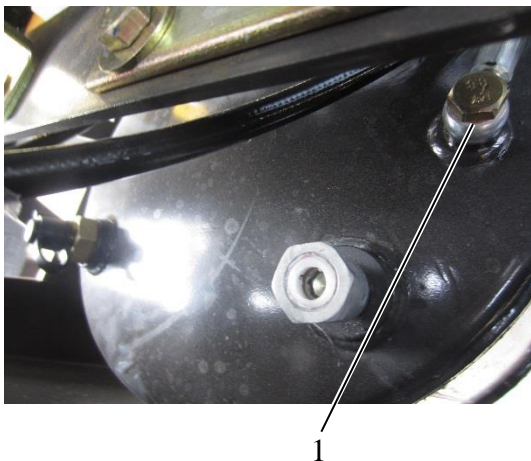

Fig 5-47
1 Gasholder to brake magnetic valve hose

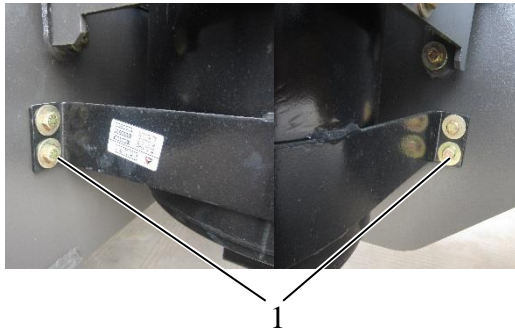

Fig. 5-48
1 Gasholder fixing bolt

3. Loose the fixing bolts of gasholder, take down the gasholder.

Assembly of gasholder

1. Fix gasholder on the frame with bolt.

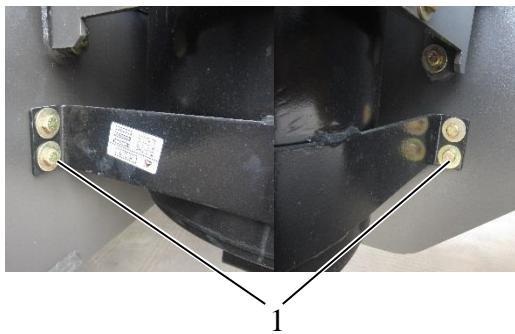

Fig. 5-49
1 Gasholder fixing bolt

2. Connect each hose and the sensor wiring harness of gasholder.

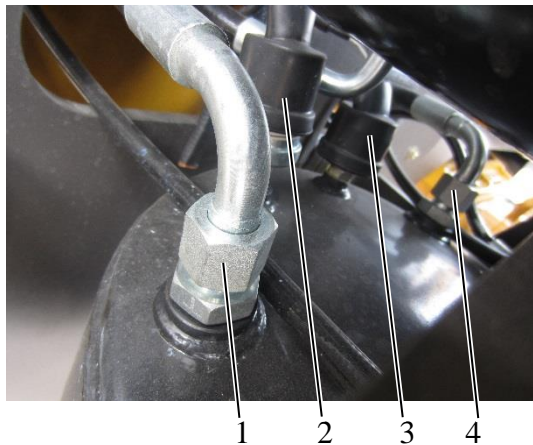

Fig. 5-50
1 Gasholder to foot brake valve hose
2 Pressure sensor
3 Emergency brake pressure switch
4 Gasholder to oil-water separator connection valve hose



1

Fig 5-51

1 Gasholder to brake magnetic valve hose

52 Parking Brake System

521 Components and Working Principle of Parking Brake System

The parking brake is used to keep loader stay at original position after stop, to avoid unexpected movement due to inclined road or external forces.

LG936L applies electric pneumatic controlled caliper disc brake.

Press down the parking brake switch, brake magnetic valve acts on parking brake to decompress the brake, internal spring extends to pull up the brake caliper, the brake caliper clamps gearbox output flange to brake the loader.

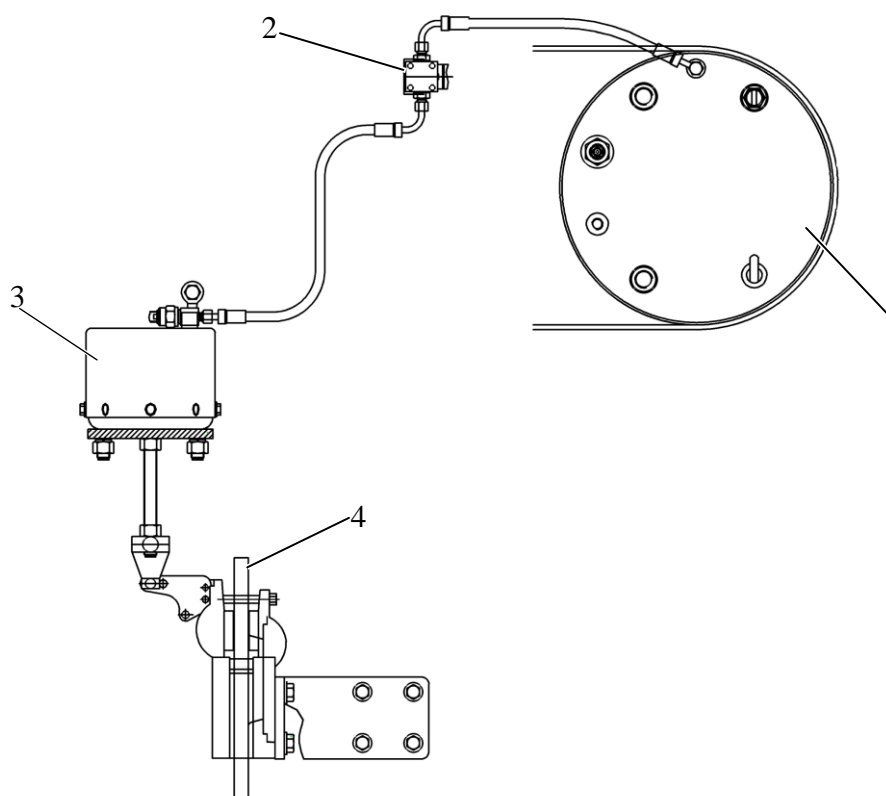

Fig. 5-52 Parking brake system

- | | |
|--------------------------|----------------------------------|
| 1 Gas holder | 2 Brake magnetic valve |
| 3 Parking brake cylinder | 4 Transmission box output flange |

522 Disassembly and Assembly of Main Components

Disassembly of parking control mechanism assembly

1. Screw up the parking brake switch, ensure the parking brake is relieved, put wood blocks under the tires, to prevent the loader sliding.

2. Remove the pin that connecting brake pull rod and brake caliper disc.

3. Open the water drain valve of gasholder to unload the brake system.



Fig. 5-53
1 Parking brake switch

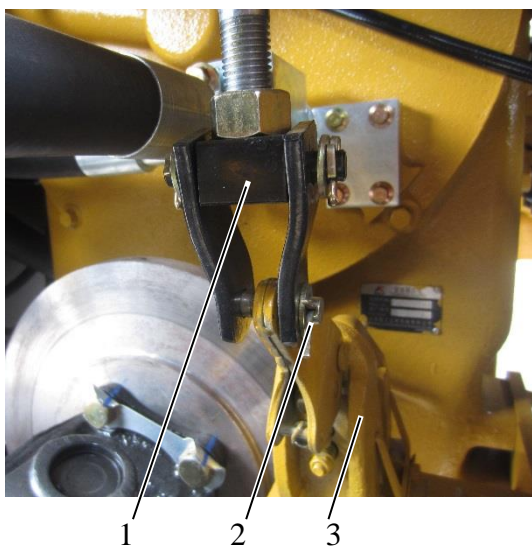

Fig 5-54
1 Brake pull rod
2 Connecting pin
3 Parking brake caliper disc

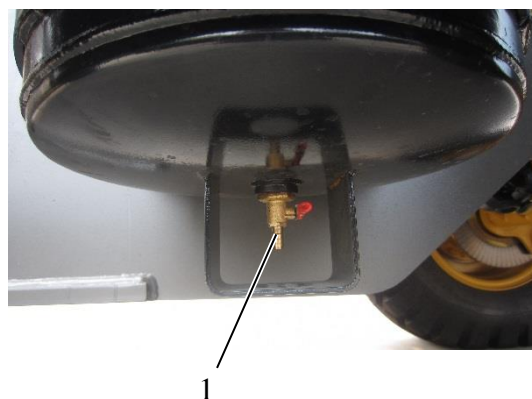

Fig. 5-55
1 Water drain valve

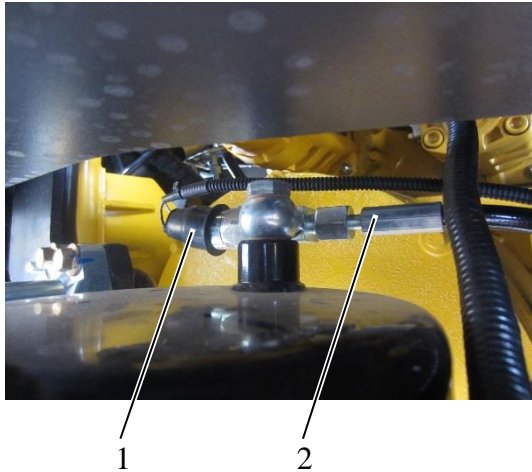

Fig. 5-56

- 1 Electronic control switch
- 2 Brake air inlet hose

4. Disassemble the electronic control switch and air inlet hose of parking brake..

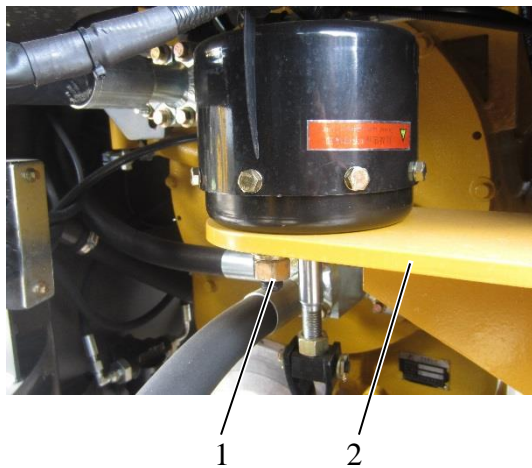

Fig. 5-57

- 1 Parking brake fixing bolt
- 2 Support

5. Disconnect parking brake fixing bolts, take down the brake.

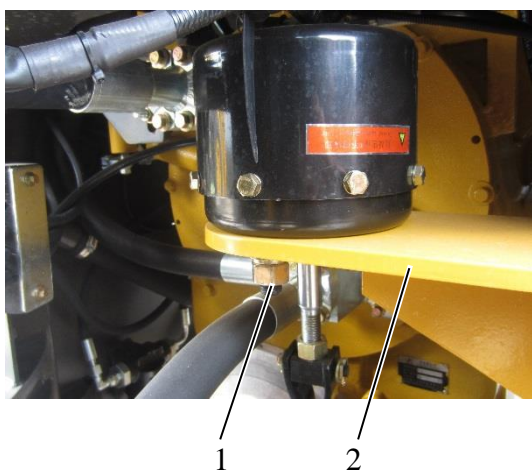
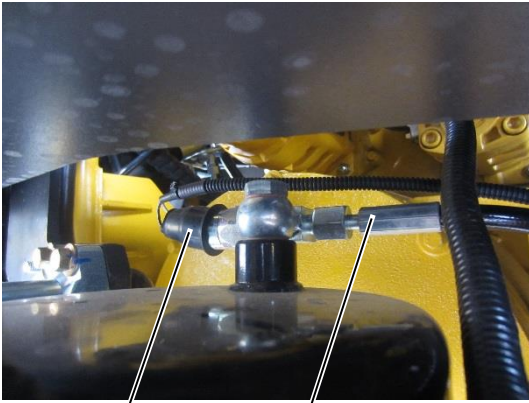

Fig. 5-58

- 1 Parking brake fixing bolt
- 2 Support

Assembly of parking control mechanism assembly

1. Fix the parking brake on the support with bolts.



1 2

Fig. 5-59

- 1 Electronic control switch
- 2 Brake air inlet hose

- 2. Connect the electronic control switch and air inlet hose of parking brake.

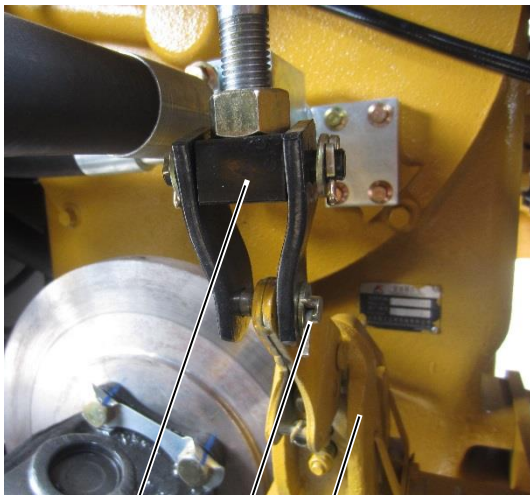

1 2 3

Fig 5-54

- 1 Brake pull rod
- 2 Connecting pin
- 3 Parking brake caliper disc

- 6. Assemble the pin to connect brake pull rod and brake caliper disc.

53 Brake System Common Faults and Troubleshooting

1. Fault phenomenon: Braking lag

1) Definition of braking lag

After brake is released, brake caliper fail to detach completely, therefore, it will still transfer partial braking torque in non-braking state.

2) Judgment method:

Since there is air infiltrated into brake system pipeline, when braking is applied, the volume of the air in pipeline decreases as the pressure rise, which leads to lag of braking effect; when braking is released, the volume of compressed air in pipeline increases, which leads to incomplete return of brake fluid and results in braking lag.

3) Check if the rear axle is locked:

The brake caliper is faulty, rectangle oil seal is damaged, and brake caliper piston cannot return successfully or internal piston is rusty. Foot brake valve is faulty, and the internal piston is stuck. Booster pump is faulty, piston in air chamber of booster pump is under abnormal wear condition, and the piston is stuck during return.

2. Fault phenomenon: Brake fluid leakage from booster pump

1) Judgment method:

Firstly find out where the leaking brake fluid comes from, and determine whether it is internal leakage or external leakage.



Damaged rectangle piston seal ring leads to incomplete return of brake piston after release. During maintenance, it is required to remove the piston end cover for replacement.

Fig. 5-61

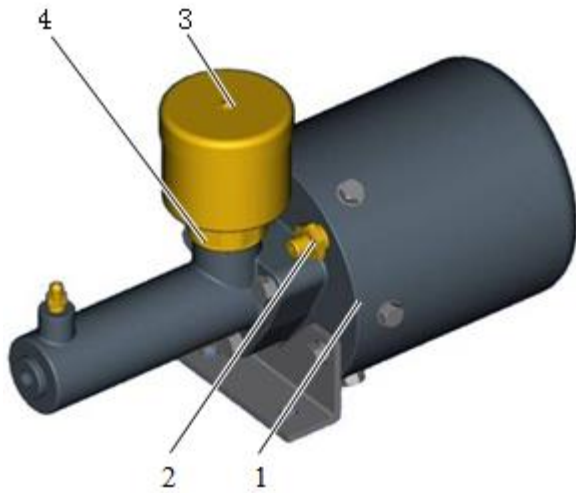

Fig. 5-62

In case of leakage in booster cylinder breather or joint surface 2, it is internal leakage caused by damaged push rod guide seal ring;

In case of leakage in joint surface 1 of pump body and end cover, it is external leakage caused by seal ring damage in the joint;

In case of leakage from joint surface 4 of oil cup and end cover, it is external leakage caused by seal ring damage in the joint;

In case of leakage in oil cup opening 3, it is caused by damaged oil seal of brake pump and brake fluid in high pressure chamber returns to low pressure chamber;

The damage of seal holder of push rod seat will also lead to oil bursting from oil cup.

3. Fault phenomenon: Sudden “No Braking”

1) What are the causes of sudden “No Braking” when loader is running? How to take emergency actions?

2) Judgment method:

If sudden “No Braking” happens under the condition that the pressure in gasholder and the residual amount of oil in oil cup of booster pump meet relevant requirements, check the following:

Air chamber rubber ring of booster pump has lip reversed suddenly or damage, and compressed air enters into low pressure chamber through the seal;

Master cylinder rubber cup of booster pump has lip reversed suddenly or has damage, brake fluid in high pressure chamber flows into low pressure chamber;

Air brake valve piston assembly is stuck

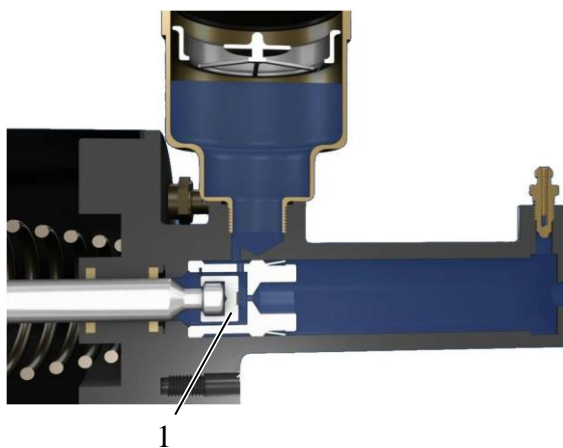

Fig. 5-63

1 Master cylinder rubber cup

suddenly and fails to push air inlet valve element down and open air inlet effectively;

4. Fault phenomenon: Braking deviation of loader

- 1) Judgment method:

The direct cause of braking deviation is unequal braking torques transferred to wheels on the left and right sides.

The brake caliper on one wheel side is locked and difficult to detach in the process of running. The common reason is that the rectangle seal ring of brake caliper has been damaged and thus fails to perform return function.

When brake pedal is depressed, brake caliper on one side will function; however, on the other side, due to internal leakage, blocked oil passage or rusty brake caliper piston, brake fluid cannot flow into brake caliper. In this case, unequal braking torque is produced, which will cause braking deviation.

5. Fault phenomenon: Loader slides when parking brake is applied.

- 1) Judgment method:

The friction between brake disc and friction disc is small.

There is oil dirty on the contact surface of brake disc and friction disc, which can reduce the friction coefficient. Eliminate the oil dirty by cleaning the brake disc and friction disc with petrol.

The control flexible shaft is not adjusted properly, so readjust the move stroke of control handle pin roll handle.

The direct contact area between friction disc and brake disc is small.



Service Manual

LG936L

Version:0610



6 Steering

CONTENTS

6	Steering System	6-1
61	General.....	6-1
611	Steering System Principle Description.....	6-2
612	Location of Steering System Parts	6-4
62	Description, Disassembly and Assembly of Main Components	6-5
621	Steering Pump.....	6-5
622	Priority Valve	6-10
623	Steering Cylinder.....	6-14
624	Steering Gear	6-19
625	Steering Column	6-24
63	Deflation of Steering System.....	6-28
64	Instructions for Steering System Pressure Test and Adjustment	6-29
641	Pressure Measurement of Steering Hydraulic System	6-29
642	Pressure Adjustment of Steering Hydraulic System	6-29
65	Diagnosis and Solutions for Common Faults of Steering System	6-30

6 Steering System

6.1 General

The loader is equipped with flow amplifying load sensing steering system actuated by single constant displacement pump, working pressure of steering system is 12MPa.

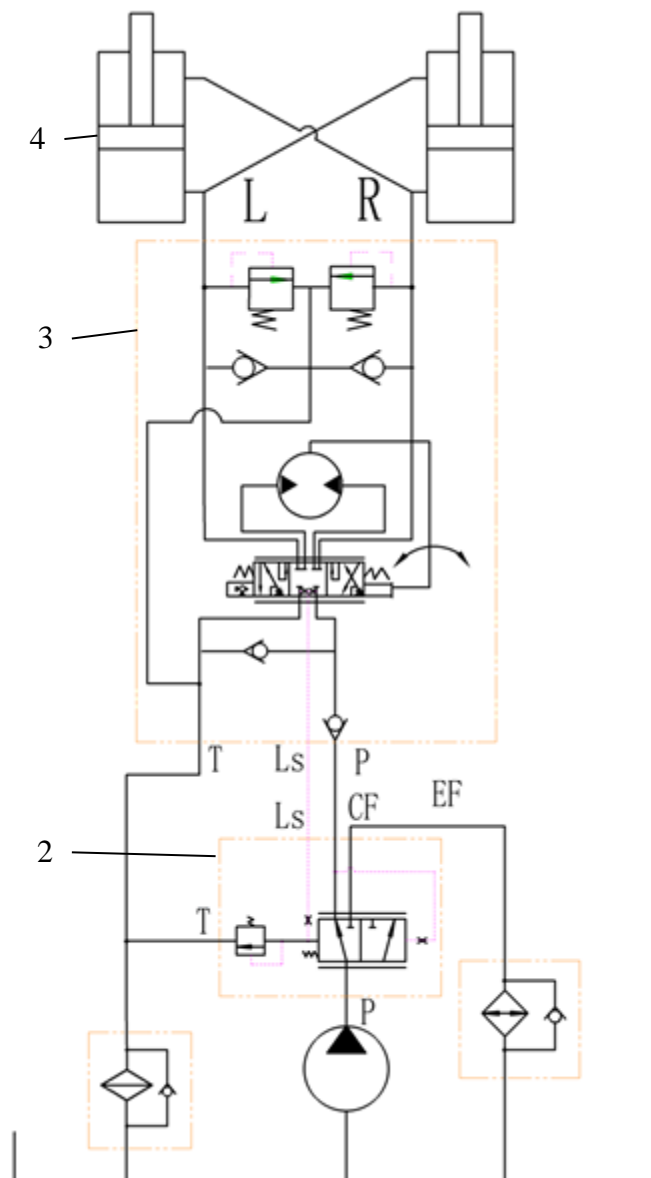

Fig. 6-1 Steering system principle diagram

1 Steering pump

2 Priority valve

3 Steering gear

4 Steering cylinder

611 Steering System Principle Description

The principle of hydraulic steering system is illustrated in Fig. 6-1, steering pump absorbs oil from hydraulic tank, then pumps oil into port P of priority valve, then the oil flows into steering gear from port CF of priority valve, When turning the steering wheel, steering gear sends pressure oil into steering cylinder to carry out front-wheel steering.

When the steering wheel is in neutral

If the engine flameout, the pump will stop supplying; the controlling spring of priority valve forces the spool right to connect port CF. After the engine is started, hydraulic oil in the tank flows into priority valve through steering pump, the priority valve allocate oil to steering gear through port CF, then it will result in pressure loss when the oil flows through steering gear neutral position throttling orifice. The two ends pressure of steering gear neutral position throttling orifice pass to two ends of priority valve spool, then the resulting pressure can balance spring force and hydrodynamic force to enable the spool stay in an equilibrium position. Due to steering gear neutral position throttling orifice can generate great fluid resistance, very small flow is needed to generate enough differential pressure to force the spool left. When the spool is forced left further, opening degree of port EF increases, while port CF decreases, at this point, oil flow in CF oil line is very small and most oil flows through port EF to working system.

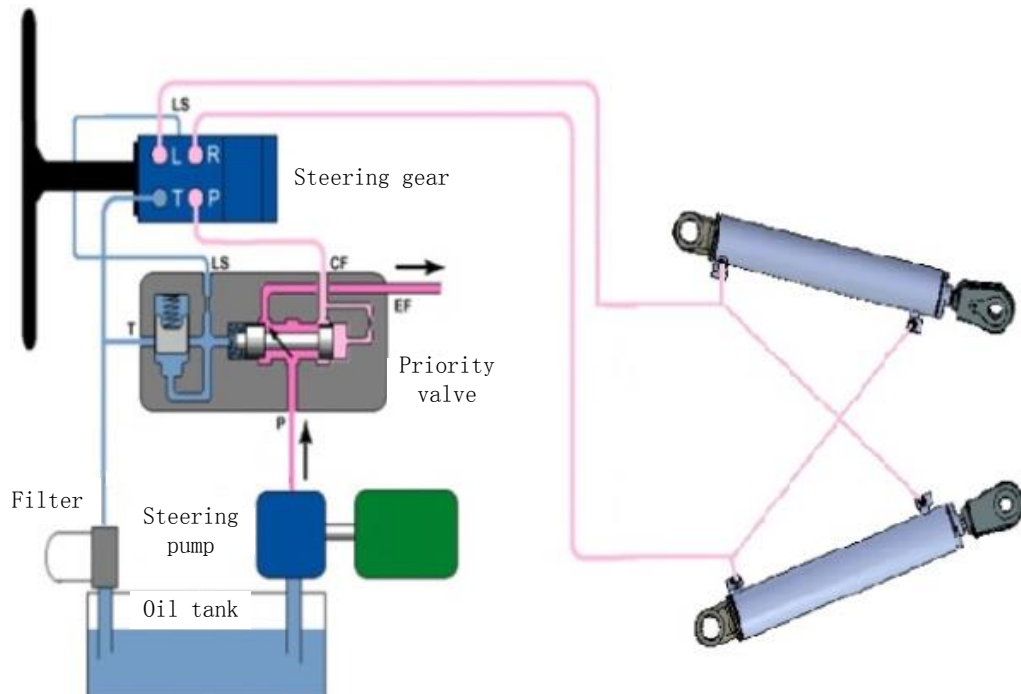

Fig. 6-2 Oil circuit when steering wheel is in neutral

When steering

When turning the steering wheel, the rotor and stator module of steering gear forms a cyclonical-pin wheel engagement pair, to act as a meter during power steering, and ensures the oil flow in steering cylinder is in direct proportion to turning angle of steering wheel. Valve element, valve bush and valve body forms a follow-up revolutes pair, used to control oil flow direction and send control signal to priority valve to change oil supply rate as the turning speed of steering wheel changes. The valve bush and steering gear stator is connected with a universal driving shaft to achieve synchronous rotation, oil enters into port P of steering gear and the valve bush wouldn't move, and control valve communicates with valve bush oil channel, then the oil flows into metering motor, the steering gear rotor starts to turn, valve bush oil channel communicates to valve element oil channel, oil flows into steering cylinder through port L to push the piston to realize steering. At this point, feedback force from port LS and the spring force jointly overcome feedback force of port CF to push the valve element of priority valve, opening degree of priority valve port CF increases and that of port EF decreases to supply more oil into steering system.

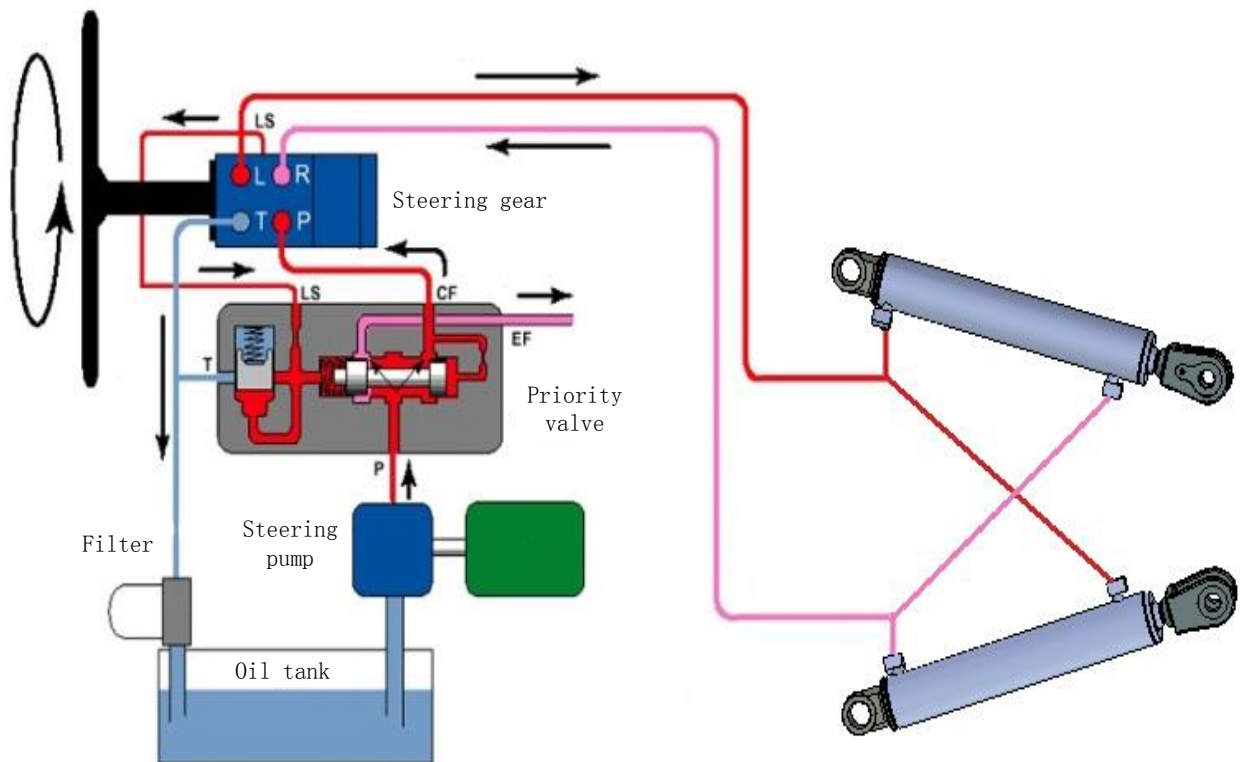

Figure 6-3 Oil circuit when steering

612 Location of Steering System Parts

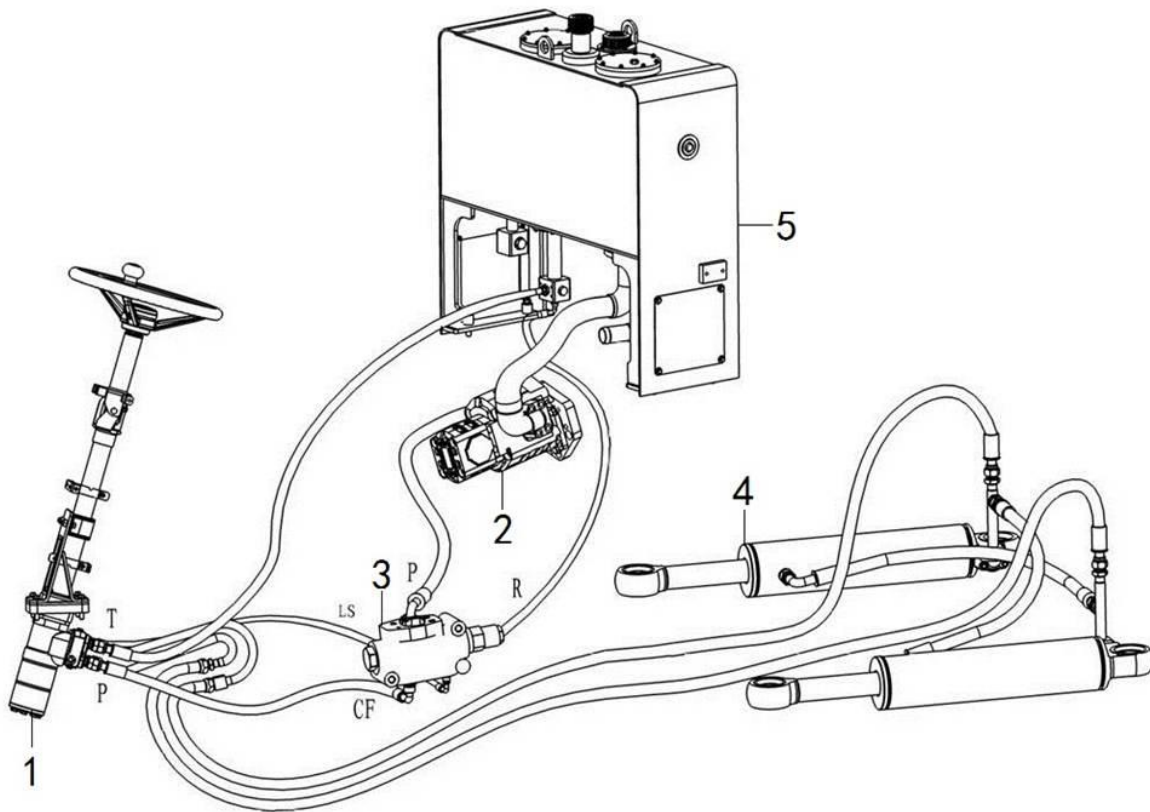

Fig. 6-4 Location map of steering system components

- | | | |
|---------------------|----------------------|------------------|
| 1 Steering gear | 2 Steering pump | 3 Priority valve |
| 4 Steering cylinder | 5 Hydraulic oil tank | |

This system is composed of steering pump, priority valve, load sensing hydraulic steering gear, steering cylinder and pipelines. It has the advantages of compact structure, high sensitivity, good stability, flexible and easy operation, shock absorption and free of extra lubricating device.

62 Description, Disassembly and Assembly of Main Components

621 Steering Pump

The steering pump is gear pump. Steering pump is connected to transmission box output port, it transmits input mechanical energy from transmission box into oil pressure energy, and outputs pressure oil flow into the system. It's the power source of steering system.



Steering pump technical parameters

Table 6-1

Connection type	Rectangular spline
Direction of turning	Left-hand
Nominal displacement	63ml/r

Fig. 6-5 Steering pump

Working principle of steering pump

When steering pump driving gear rotates clockwise, the gear demeshes on oil absorption chamber side (A), oil absorption chamber volume increases and partial vacuum will be formed, oil in the tank will be pressurized into absorption chamber under the force of atmospheric pressure to fill up the inter-tooth space. As the gear rotates, oil in transition area B will be brought into oil extrusion chamber C, the gear meshes on the extrusion side and the volume decreases to force oil into oil circuit.

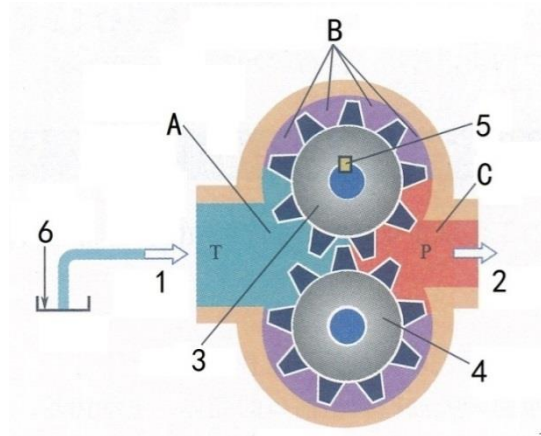

Fig. 6-6 Working principle of steering pump

1 Oil absorption port

2 Oil extrusion port

3 Driving gear

4 Driven gear

5 Spline

6 Hydraulic oil tank

Fault diagnosis of steering pump

Table 6-2

No.	Fault phenomenon	Cause	Elimination method
1	Oil leakage of pump body junction surface.	Damaged O-ring or loose bolt.	Replace the O-ring or fasten the bolt.
2	Oil leakage of pump body.	Bump body defect.	Check and replace the steering pump.
3	Abnormal sound produced by steering pump.	Excessive wear of spline shaft.	Replace the spline shaft or steering pump.
		Excessive wear of side plate.	Replace the side plate or steering pump.
		Out of tolerance of spine shaft.	Replace the spline shaft or steering pump.
		Bearing failure.	Replace the bearing or steering pump.
4	Insufficient output flow result in slow motion.	Excessive wear of side plate or gear.	Replace the relevant parts or steering pump.

Disassembly and assembly of steering pump

★ATTENTION

Before disassemble the steering pump, please park the machine on maintenance position properly. When dismantling the hydraulic pipeline, do not screw off the pipe joint bolts rashly. Loosen the bolt gradually until the oil spills out so as to prevent oil splashing due to incomplete oil discharging. When dismantling the hydraulic pipeline, necessary protective measures should be taken for each pipeline and oil port to prevent debris like dust from entering the steering system.

During dismantling the steering system, please collect the remnant hydraulic oil with appropriate vessel when disconnecting a pipe, and pour the collected oil into a dedicated hydraulic oil recycling bin after the maintenance work. When assembling, be sure to replace the seal with a new one, related standards of tightening torque in this manual must be strictly followed.



Fig. 6-7



1

Fig. 6-8

1 Ball valve

Disassembly of steering pump

1. Pressure relief.

Start the machine and drive it to a capacious flat place. Raise the boom to the highest position, tilt the bucket backward to its extreme position, and then shut down the engine. Push pilot valve control handle rightwards slowly, let the bucket tilt forward under the action of self-weight to drain the oil in bucket cylinder out.

After the bucket getting to its extreme position, push forward the handle gently. Let the boom declines under the effect of self-weight to drain the oil in the boom cylinder. Keep the bucket flat on ground. Then push the control handle all around for 5~6 times and turn the steering wheel clockwise and anticlockwise for 5~6 times to drain the internal oil pressure of the system.

2. Put an appropriate vessel aside the hydraulic tank, connect a hose to ball valve of hydraulic tank, then open the valve to drain oil into the vessel.

★ ATTENTION

Cover up the drained oil to prevent contamination. Determine whether the oil should be discarded or reused according to hydraulic oil draining period. Handle the discarded oil in an environmental way, and be sure to filter the oil before filling if reuse.

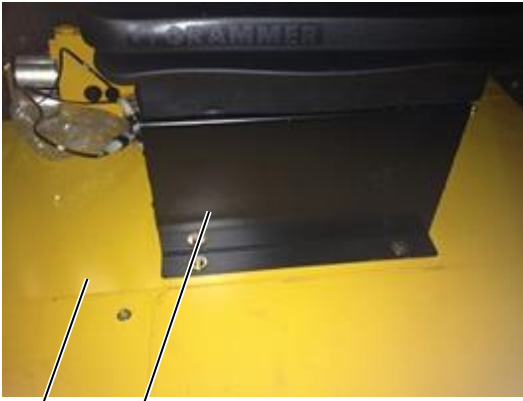

1 Maintenance cover plate 2 Seat

- Remove the fixing bolts of seat support, take down the seat-support assembly and maintenance cover plate.



1 Oil outlet steel pipe
2 Steering pump
3 Oil absorption steel pipe

- Loosen the connecting bolts of steering pump oil absorption steel pipe, remove the bolt-pipe assembly; Disconnect oil outlet steel pipe from steering pump, take down the flange, O-ring and oil outlet steel pipe.



1 Stud. nut, gasket

- Hang the steering pump with lifting appliance, remove the connecting bolts between steering pump and transmission box flange, take down the nuts and gaskets and lift the pump to a proper place.

★ATTENTION

Hang the steering pump stably to prevent falling and crashing the machine.

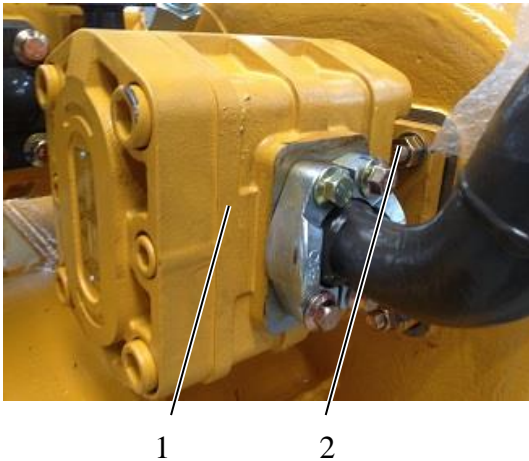
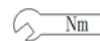

Fig. 6-12
 1 Steering pump
 2 Stud. nut, gasket

Assembly of the steering pump

1. At first, install the four connecting studs on transmission box end face. And Install the sealing gasket used for pump on the front end of steering pump, hang the pump with lifting appliance and connect it to the four studs, then use four M12 nuts and gaskets to fix the pump on transmission box.

 Nm 70~80Nm

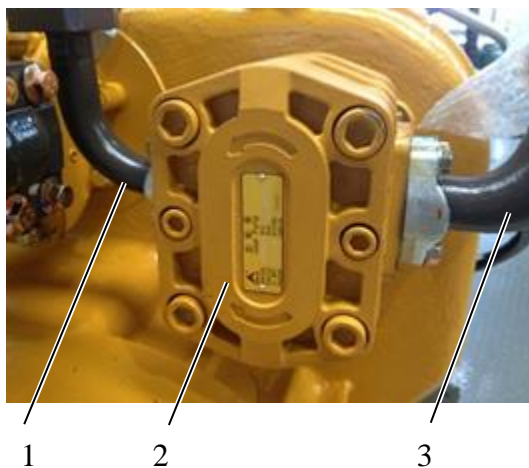

Fig. 6-13
 1 Oil outlet steel pipe
 2 Steering pump
 3 Oil absorption steel pipe

2. Install O-ring in the O-ring groove of steering pump absorption steel pipe joint. Tighten the pipe on oil absorption port of steering pump with four M12 bolts; Fix the outlet hose on outlet steel pipe of steering pump with four M10 bolts.

★ ATTENTION

When installing the O-ring, put the ring in the O-ring groove with hand and flatten it. Check whether the flange junction surface is even by visual after assembly.

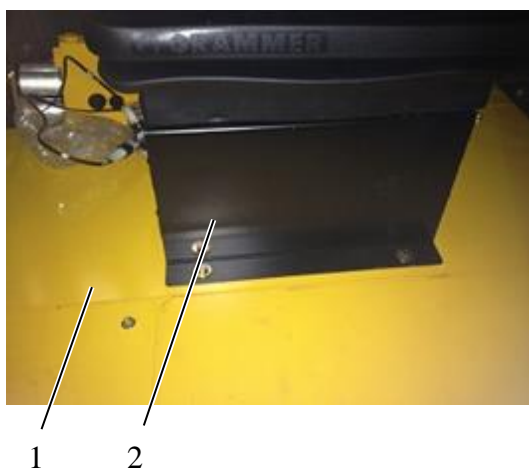

Fig. 6-14
 1 Maintenance cover plate 2 Seat

3. Install maintenance cover plate. Fix the seat-support assembly on cab board with bolts.

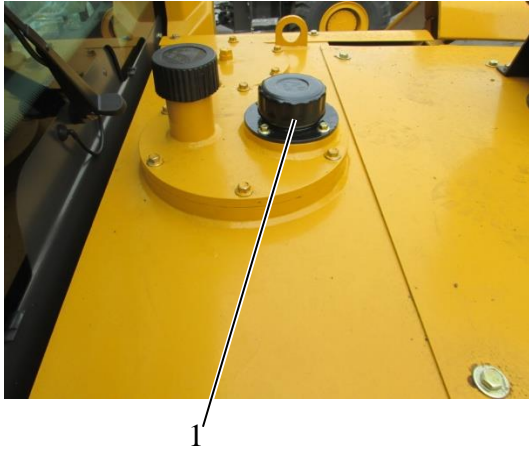

Fig. 6-15
1 Filling filter

4. Close the ball valve, and open the hydraulic tank filling filter to fill hydraulic oil. Start the engine, and check the hydraulic oil level by the round oil pointer on the left side of hydraulic tank after the engine becomes stable.

622 Priority Valve

The priority valve is a constant differential reducing component. Regardless of the change in loading pressure and oil supply, the priority valve can maintain almost the same pressure differential between two ends of variable orifice, which can ensure the flow valve in the steering gear always equal to the product of steering wheel rotating speed times steering gear displacement.

Port P of priority valve is connected to steering pump oil outlet hose, port CF is connected to port P of steering gear, port EF is connected to port P of multitandem valve, and port LS is connected port LS of steering gear.

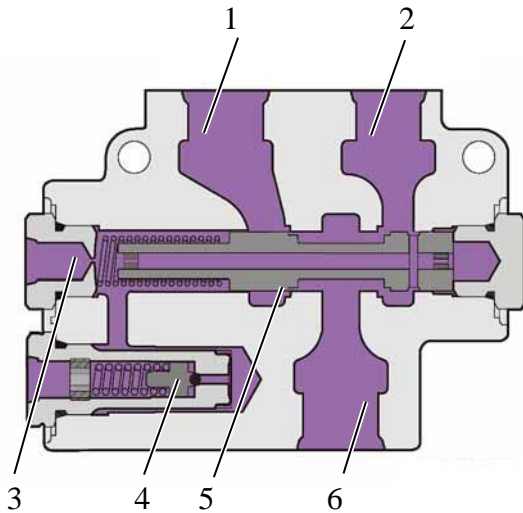

Fig.6-16 Priority valve inner structure diagram

1 EF port 2 CF port 3 LS port 4 Safety valve 5 Priority valve element 6 P port

Working principle of priority valve

Priority valve is mainly composed of valve body, valve element, safety valve module and spring. The priority valve matched with BZZ5 steering gear to compose a load sensing steering system.

Priority valve technical parameters

Table 6-3

Normal rate	flow	150L/min
Safety pressure	valve	12MPa
Control pressure		6.9MPa
Signal		Static signal

When turning speed of steering wheel changes, the valve is able to ensure the priority of oil flow for steering system, to satisfy the steering-first working condition, the extra oil goes into working hydraulic system.

When steering wheel is in neutral, the follow-up rotary valve of steering gear is in neutral too, due to steering gear neutral position throttling orifice can generate great fluid resistance, only very small amount oil from steering pump goes through the throttling orifice, most oil flows into priority valve right end. Due the left channel of priority valve is disconnected when the safety valve is closed, so there is very small flow goes into priority valve LS port from the two ends of neutral position throttling orifice. If the flow force on right end of priority valve element is bigger than the sum of flow force on left end and spring force, the valve element will be forced left, at this point, open degree of port EF increases while port CF decreases, most oil flows through port EF to working system.

When steering, the valve element will be forced right under the combined action of flow force from EF port, flow force from LS port and spring force, open degree of port CF increases while port EF decreases, most oil flows into steering gear port P through port CF of steering gear to carry out steering. If steering resistance increases, redundant oil goes into working hydraulic system through priority valve port EF. That is, priority valve can realize the converging of steering hydraulic system and working hydraulic system under the premise of satisfying steering system first, it is a way of reducing power loss and conserving energy.

During steering, if the loading pressure exceeds the set pressure value of 12MPa, oil from port LS will push open the safety relief valve poppet to relief pressure from the spring end of the valve. Under the action of pressure oil, priority valve element will move towards the spring end to reduce oil flow to steering gear. When loading pressure reduces, priority valve element will move towards the non-spring end under the dual function of spring and control oil to increase oil supply.

Disassembly and assembly of priority valve

★ATTENTION

When dismantling the hydraulic pipeline, do not screw off the pipe joint bolts rashly. Loosen the bolt gradually until the oil spills out so as to prevent oil splashing due to incomplete oil discharging. When dismantling the hydraulic pipeline, necessary protective measures should be taken for each pipeline and oil port to prevent debris like dust from entering the steering system. During dismantling the steering system, please collect the remnant hydraulic oil with appropriate vessel when disconnecting a pipe, and pour the collected oil into a dedicated hydraulic oil recycling bin after the maintenance work.

When assembling, be sure to replace the seal with a new one, related standards of tightening torque in this manual must be strictly followed.



Fig. 6-17

Disassembly of priority valve

1. Pressure relief. Refer to page 6-7.

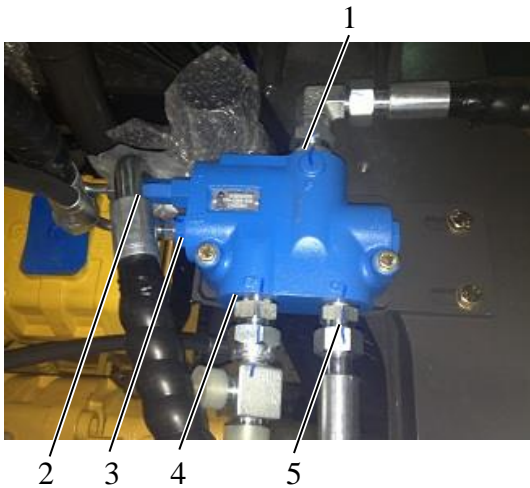

Fig. 6-18

- 1 Oil inlet rubber pipe
- 2 Oil return rubber pipe
- 3 Rubber pipe (Port LS)
- 5 Rubber pipe (Port EF)
- 6 Rubber pipe (Port CF)

2. Remove the oil inlet rubber pipe, oil outlet rubber pipe of priority valve and other three rubber pipes for each port of the valve; Remove the assembly joint from CF port rubber pipe.

★ ATTENTION

Mark the hose orderly to prevent confusion.

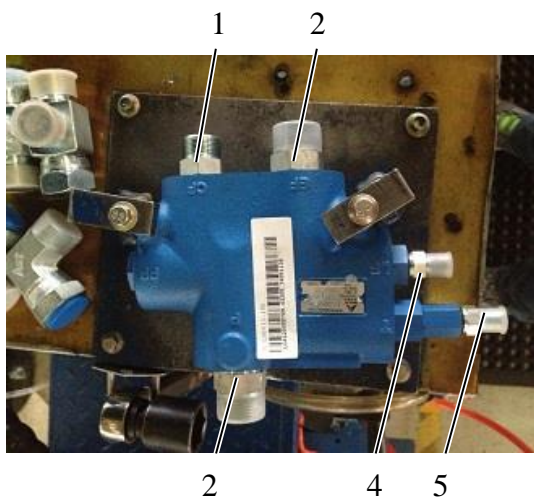

Fig. 6-19

- 1 Straight joint (Port CF)
- 2 Straight joint (Port EF)
- 3 Straight joint (Port P)
- 4 Straight joint (Port LS)
- 5 Straight joint (Port T)

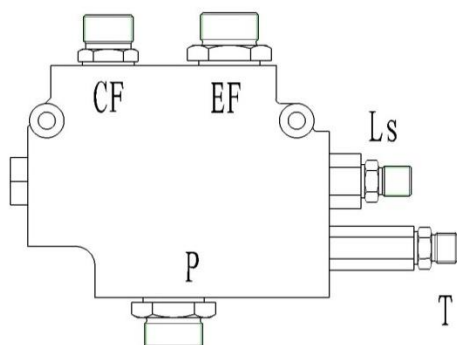

Fig. 6-20



Fig. 6-21

3. Remove the fixing bolts of priority valve, take down the valve.
4. Remove the priority valve oil port joints and O-rings.

Assembly of the priority valve

5. Install each straight joint with an O-ring to the corresponding oil port of priority valve.

6. Fix the priority valve on the rear frame left fixed board with two bolts; Connect the priority valve oil return pipe to the valve T port and the priority valve feedback oil pipe to the port LS; Connect the steering gear oil inlet pipe to the valve CF port and the radiator oil inlet pipe to port EF.

 Nm Fixing bolt: 22~30Nm

 Nm Oil return rubber pipe: 25~35Nm

 Nm Priority valve feedback oil pipe:
25~35Nm

 Nm Steering gear oil inlet rubber pipe:
75~95Nm

 Nm Radiator oil inlet pipe: 100~130Nm

7. Close the ball valve, and open the hydraulic tank filling filter to fill hydraulic oil. Start the engine, and check the hydraulic oil level by the round oil pointer on the left side of hydraulic tank after the engine becomes stable.



1

Fig. 6-22
1 Filling filter

623 Steering Cylinder

Steering cylinder is used to transmit pressure energy of hydraulic oil into mechanical energy of reciprocal rectilinear motion. The cylinder is fixed on the frame with pin, and steering function is realized by stretching out and drawing back of cylinder piston. Steering cylinder is mainly composed of cylinder block, piston rod, cylinder head and seals.

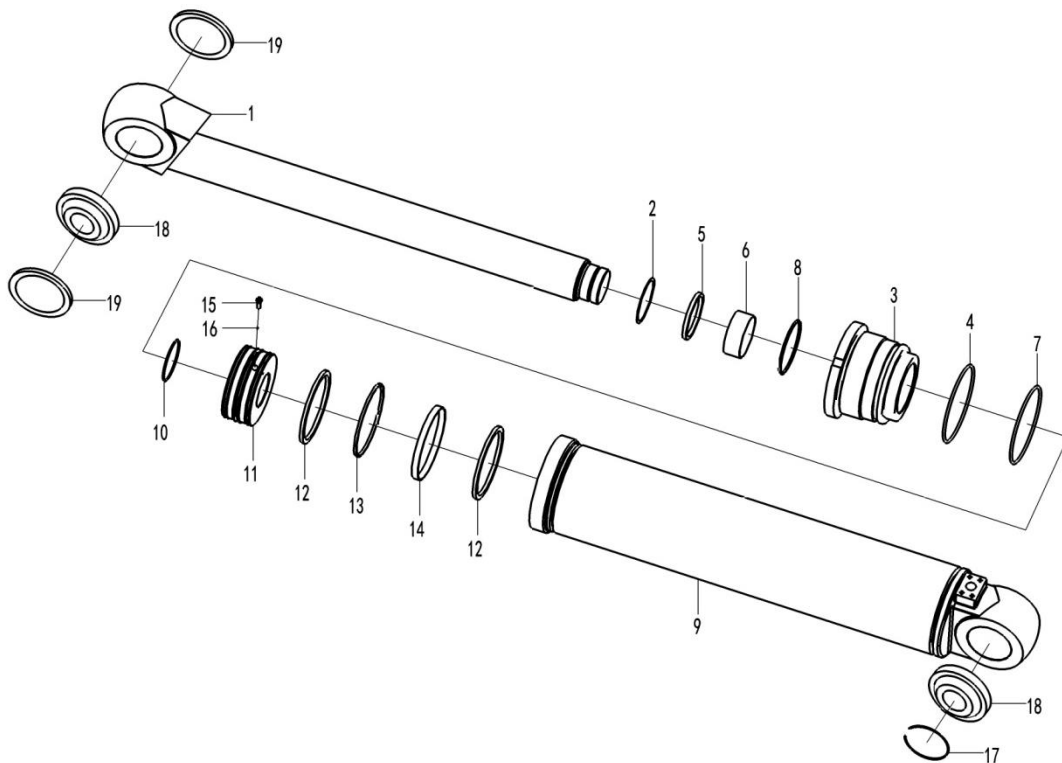

Fig. 6-23 Steering cylinder inner structure drawing

Table 6-4

No.	Name	Qty.	Comment	No.	Name	Qty.	Comment
1	Piston rod	1		11	Piston	1	
2	Seal	1	Dust ring	12	Seal	1	Contaminant seal
3	Cylinder cover	1		13	Seal	1	Combination seal
4	Seal	1	O-ring	14	Seal	1	Guide ring
5	Seal	1	U-ring	15	Screw	1	
6	Seal	1	Guide ring	16	Steel ball	1	
7	Seal	1	O-ring	17	Retainer ring	1	
8	Seal	1	Combination seal for shaft	18	Bearing	2	
9	Cylinder block	1		19	Stop dog	2	
10	Seal	1	O-ring				

Disassembly and assembly of steering cylinder

★ ATTENTION

When dismantling the hydraulic pipeline, do not screw off the pipe joint bolts rashly. Loosen the bolt gradually until the oil spills out so as to prevent oil splashing due to incomplete oil discharging. When dismantling the hydraulic pipeline, necessary protective measures should be taken for each pipeline and oil port to prevent debris like dust from entering the steering system.

During dismantling the steering system, please collect the remnant hydraulic oil with appropriate vessel when disconnecting a pipe, and pour the collected oil into a dedicated hydraulic oil recycling bin after the maintenance work. When assembling, be sure to replace the seal with a new one, related standards of tightening torque in this manual must be strictly followed.



Fig. 6-24

Disassembly of steering cylinder

1. Pressure relief. Refer to page 6-7.

2. Remove the rod-side rubber hoses of left and right steering cylinder and the steering gear hose, remove the fixing bolts of steel pipe, and take down the pipe.

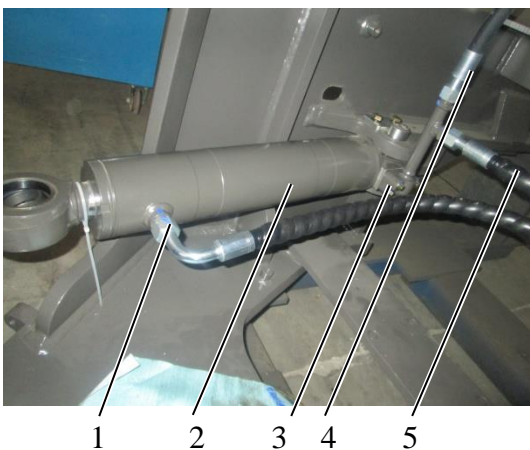
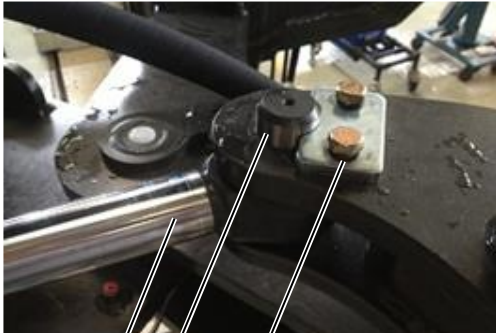

Fig. 6-25

- 1 Rod-side rubber hose of left cylinder
- 2 Steering cylinder 3 Steel pipe, bolt
- 4 Steering gear hose
- 5 Rod-side rubber hose of right cylinder



1 2 3

Fig. 6-26

- 1 Kingpin card board, bolt
- 2 Kingpin
- 3 Steering cylinder

3. Remove the fixing bolts of kingpin card board, take down the card board and kingpin.



1 2 3

Fig. 6-27

- 1 Kingpin card board, bolt
- 2 Oil-through bolt, gasket, hose
- 3 Kingpin

4. Remove the oil-through bolt of steering cylinder, take down the bolt, gasket and hose; remove the fixing bolts of kingpin card board, take down the card board and kingpin; Hang the cylinder to a proper place with lifting appliance.

Assembly of the steering cylinder

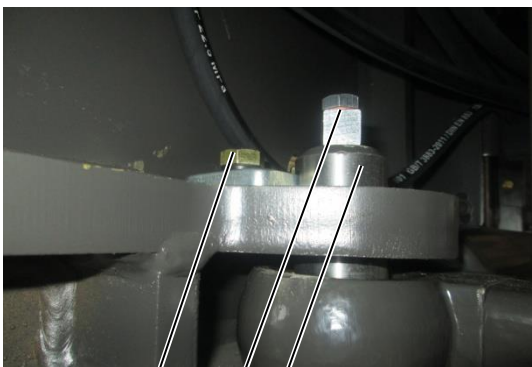

1 2 3

Fig. 6-28

- 1 Kingpin card board, bolt
- 2 Oil-through bolt, gasket, hose
- 3 Kingpin

1. Hang the cylinder to a proper place with lifting appliance, fix the cylinder piston on front frame with kingpin, and fasten the kingpin card board on the frame with bolts; Fix the hose on kingpin with oil-through bolt and gasket.

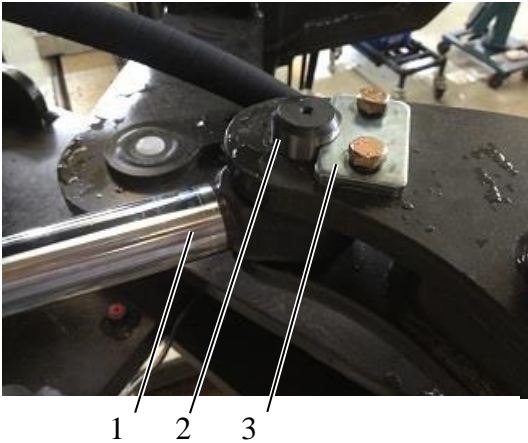
Fig. 6-29

- 1 Steering cylinder
- 2 Kingpin
- 3 Kingpin card board, bolt

2. Fix the cylinder block on rear frame with pin, fasten the kingpin card board on the frame with bolts

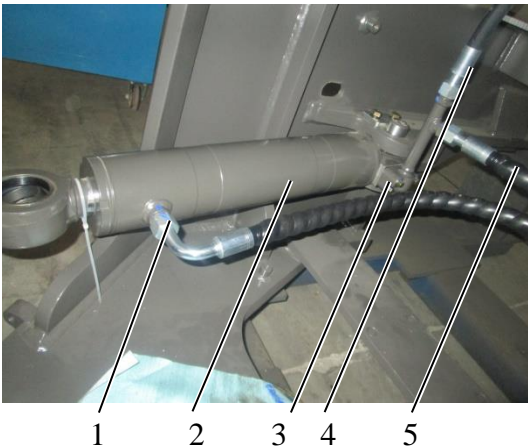
Fig. 6-30

- 1 Rod-side rubber hose of left cylinder
- 2 Steering cylinder
- 3 Steel pipe, bolt
- 4 Steering gear hose
- 5 Rod-side rubber hose of right cylinder

3. Connect the rod-side rubber hose of left cylinder to cylinder block and tighten it; Connect the steel pipe to cylinder block with four bolts and tighten it, then connect rod-side rubber hose of right cylinder and steering gear hose to the steel pipe.

 Nm Rod-side rubber hose of left cylinder: $110 \pm 10 \text{Nm}$

Steering gear hose: $110 \pm 10 \text{Nm}$

Rod-side rubber hose of right cylinder: $110 \pm 10 \text{Nm}$

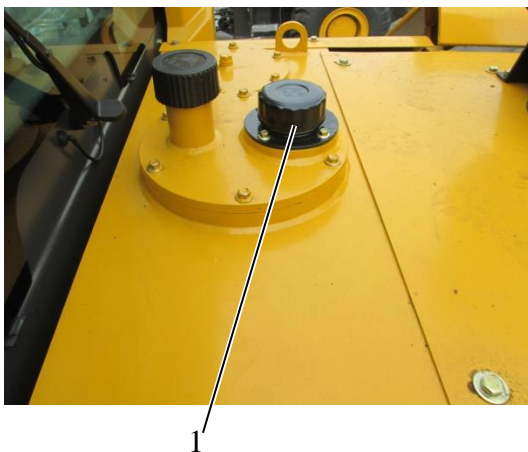
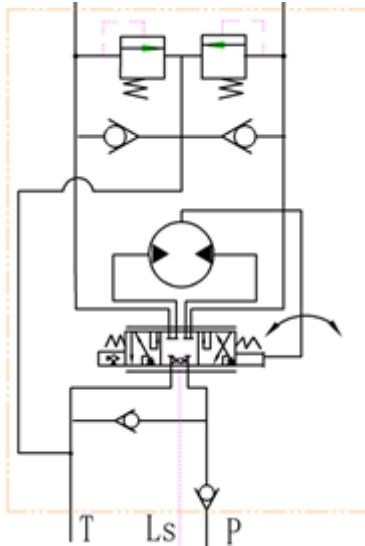

Fig. 6-31

- 1 Filling filter

4. Close the ball valve, and open the hydraulic tank filling filter to fill hydraulic oil. Start the engine, and check the hydraulic oil level by the round oil pointer on the left side of hydraulic tank after the engine becomes stable.

624 Steering Gear

The load adopts static signal load sensing non- reactive steering gear.



Main technical parameters of steering gear

Table 6-5

Connection type	British involute spline
Equivalent displacement	500ml/r
Max. inlet pressure	17.2MPa
Max. continuous backpressure	1.0MPa

Fig. 6-32 Steering gear schematic diagram

Port P of steering gear is connected to Port CF of priority valve, port L and port R connect to steering cylinder respectively, and oil flows out from port T into oil tank. Port LS of steering gear is connected to port LS of priority valve, and steering gear is connected to steering column.

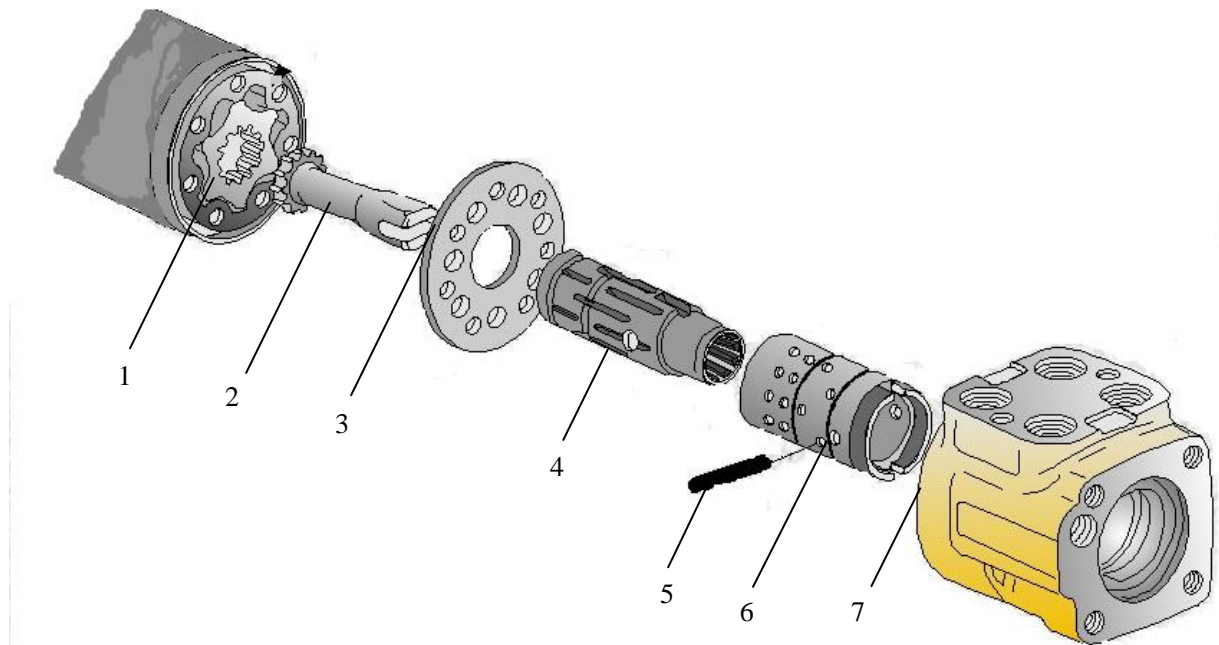

Fig 6-33 Steering gear inner structure drawing

1 Stator-rotor assembly

2 Coupling

3 Clapboard

4 valve element

5 Pull pin

6 Valve bush

7 Housing

Steering gear is mainly composed of follow-up rotatory valve and metering rotor. Follow-up rotatory valve consists of valve element, valve bush and valve body; metering motor consists of rotor and stator. The stator and rotor act as a hydraulic motor during normal steering, it can also act as a manual pump when there is an engine failure or the oil supply stopped.

Bi-directional overload valve function: When the steering cylinder is influenced by external shock, pressure of oil in the cylinder will rise and if it gets to set value (20MPa) of overload valve, the valve will open to load off to protect the cylinder.

Bi-directional oil compensation valve function: When the steering cylinder is influenced by external shock and produced transient negative pressure, the compensation valve will open and supply oil into steering cylinders to avoid cavitation phenomenon. Normally the bi-directional overload valve is overload the compensation valve opens.

Disassembly and assembly of steering gear

★ ATTENTION

When dismantling the hydraulic pipeline, do not screw off the pipe joint bolts rashly. Loosen the bolt gradually until the oil spills out so as to prevent oil splashing due to incomplete oil discharging. When dismantling the hydraulic pipeline, necessary protective measures should be taken for each pipeline and oil port to prevent debris like dust from entering the steering system. During dismantling the steering system, please collect the remnant hydraulic oil with appropriate vessel when disconnecting a pipe, and pour the collected oil into a dedicated hydraulic oil recycling bin after the maintenance work.

When assembling, be sure to replace the seal with a new one, related standards of tightening torque in this manual must be strictly followed.



Fig. 6-34

Disassembly of steering gear

1. Pressure relief. Refer to page 6-7.



1 2

Fig. 6-35

1 Left steering cylinder working rubber hose

1 Right steering cylinder working rubber hose

- Put an appropriate vessel under the steering gear and remove the two working rubber hoses of steering cylinder.

★ ATTENTION

Mark the hose orderly to prevent confusion. Put the removed hose higher than oil level in hydraulic tank to prevent oil outflow.

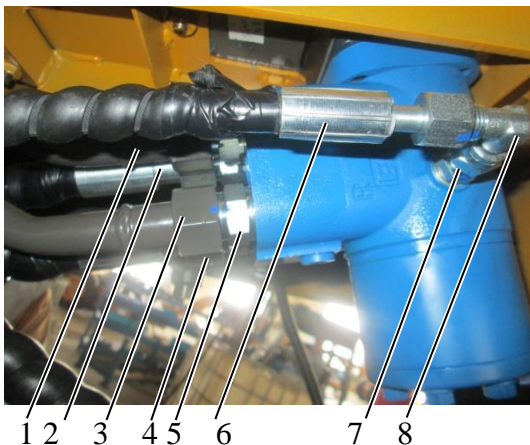

Fig. 6-36

1 Steering gear outlet steel pipe A

2 Steering gear oil return hose

3 Steering gear outlet steel pipe A

4 Priority valve hose

5 Straight joint

6 Priority valve feedback hose

7 Straight joint 8 Assembly joint

- Remove the two steering gear outlet steel pipes, steering gear oil return hose, priority valve hose and priority valve feedback hose; Disconnect the connection between assembly joint and straight joint, remove the five straight joints from steering gear.



Fig. 6-37

4. Remove the fixing screws of left and right bottom cover beneath the instrument table, take down the cover.

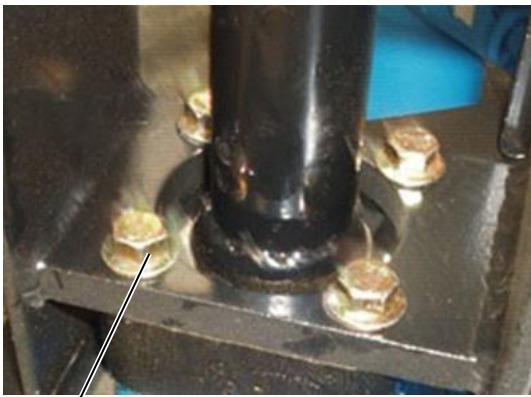
Fig. 6-38
1 Bolt

5. Remove the four connecting bolts between steering column and steering gear, take down the steering gear.

★ATTENTION

Hold the steering gear with hand or something to prevent falling.

Assembly of steering gear

1. Properly place the cross-shaped block into the steering gear, hold up the steering gear and align it with steering column (try to turn the steering wheel left and right gently to align them), fix the gear with bolts.



Fig. 6-39



Fig. 6-40

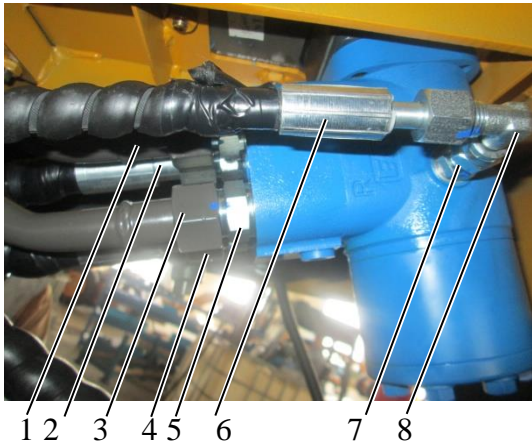

Fig. 6-41

- 1 Steering gear oil outlet steel pipe A
- 2 Steering gear oil hose
- 3 Steering gear oil outlet steel pipe B
- 4 Priority valve hose
- 5 Straight joint (LGB120)
- 6 Priority valve feedback hose
- 7 Straight joint
- 8 Assembly joint

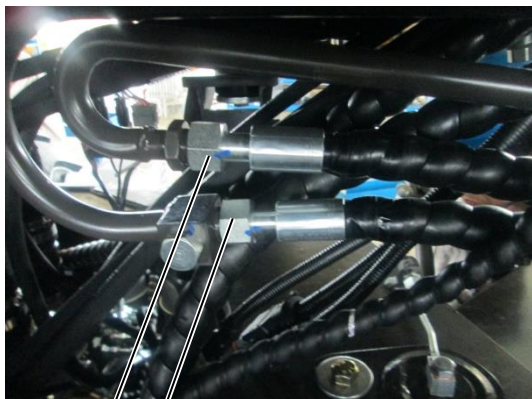



Fig. 6-42

- 1 Left steering cylinder working rubber hose
- 1 Right steering cylinder working rubber hose

2. Fix the steering column bottom cover on the steering column with trim screws and connecting screws.

3. Connect the five straight joints to steering gear, and then connect assembly joint to straight joint; Connect steering gear oil outlet steel pipe to straight joint tightly.

 Nm Steering gear outlet steel pipe A: $170 \pm 17 \text{Nm}$

 Nm Steering gear oil hose: $170 \pm 17 \text{Nm}$

 Nm Steering gear outlet steel pipe B: $170 \pm 17 \text{Nm}$

 Nm Priority valve hose: $170 \pm 17 \text{Nm}$

 Nm Straight joint (LGB120): $80 \pm 8.0 \text{Nm}$

 Nm Priority valve feedback hose: $45 \pm 4.5 \text{Nm}$

 Nm Straight joint: $35 \pm 3.5 \text{Nm}$

 Nm Assembly joint: $45 \pm 4.5 \text{Nm}$

4. Connect the two steering cylinder working rubber hoses to steering gear steel pipes.

 Nm Steering cylinder working rubber hose: $110 \pm 10 \text{Nm}$

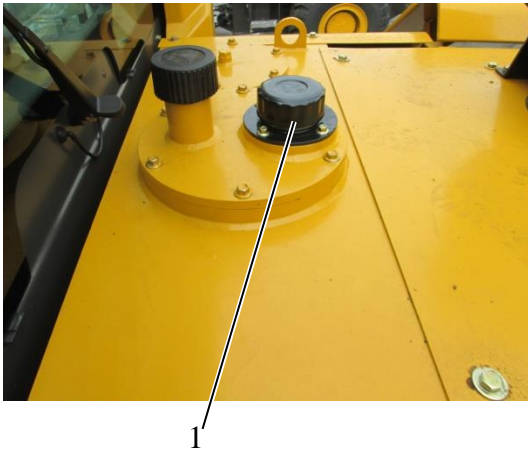

Fig. 6-43
1 Filling filter

- Close the ball valve, and open the hydraulic tank filling filter to fill hydraulic oil. Start the engine, and check the hydraulic oil level by the round oil pointer on the left side of hydraulic tank after the engine becomes stable.

625 Steering Column

The upper end of steering column is connected with steering wheel, while the lower end is connected with steering gear, shielded by steering column bottom cover. Steering column is mainly composed of rolling support, fixed support, locking handle, cardan joint, steering gear connecting shaft and fixed seat.

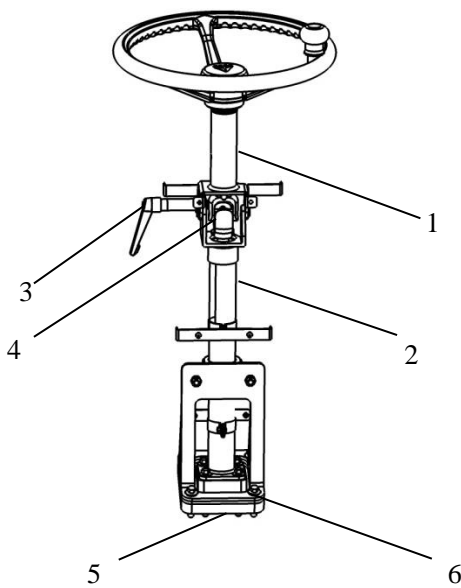

Fig. 6-44 Steering column structure drawing

- | | | | |
|----------------------------------|-----------------|------------------|----------------|
| 1 Rolling support | 2 Fixed support | 3 Locking handle | 4 Cardan joint |
| 5 Steering gear connecting shaft | 6 Fixed seat | | |

Locking handle is used to adjust forward and backward inclination angle of the steering column. Under normal condition the locking handle is in locking state and inclination angle of the steering

Main technical parameters of steering column

Table 6-6

Connection type	SAE involute spline
Angle of inclination	Forward 15°, backward 13°

column cannot be changed at this point. When rotating the locking handle anticlockwise, there will be a gap formed between locking handle and cardan joint to allow the operator to adjust the inclination angle. The operator should choose a suitable driving position according to study of man-machine relationship and turn the handle clockwise to tighten it after adjusting, at this point, only the steering wheel is allowed to turn.

Disassembly and assembly of steering column

★ATTENTION

When dismantling the hydraulic pipeline, necessary protective measures should be taken for each pipeline and oil port to prevent debris like dust from entering the steering system.

When assembling, related standards of tightening torque in this manual must be strictly followed.



1 2

Fig. 6-45

- 1 Steering wheel
- 2 Gear fender apron

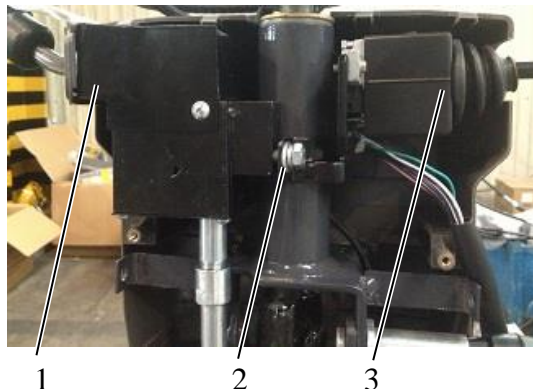

1

2

3

Fig. 6-46

- 1 Gear shifting control handle
- 2 Bolt
- 3 Combination switch

Disassembly of steering column

1. Remove the steering wheel, and then remove the gear fender apron and front and rear covers of steering column, finally remove the rubber sleeve and steering column bottom cover.
2. Remove the gear shifting control handle and combination switch.

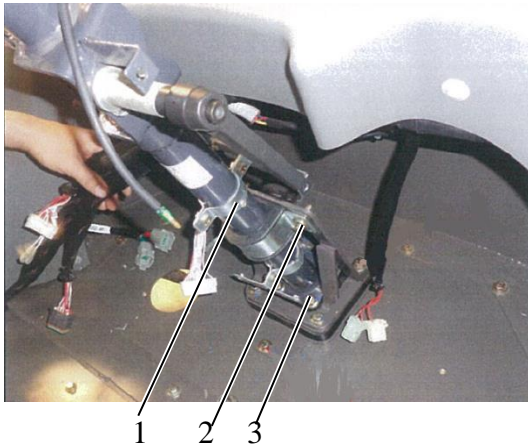
Fig. 6-47

- | | |
|-------------------|---------------|
| 1 Pipe clamp | 2 Fixing bolt |
| 3 Connecting bolt | |

- Remove the fixing bolts of steering column pipe clamp and connecting bolts used to connect the steering column and steering gear, take down the steering column (with clamps), remove the clamps and put the steering column on a proper place.

★ATTENTION

Hold the steering column with hand or something to prevent falling.

Assembly of steering column

- Install steering column pipe clamps with gaskets, screws and bolts.

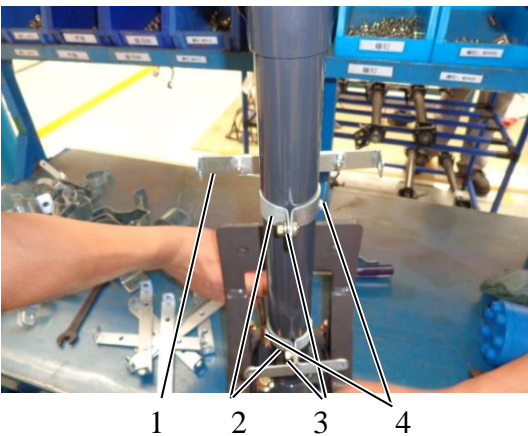
Fig. 6-48

- | | |
|------------------------|--------------|
| 1 Pipe clamp | 2 Pipe clamp |
| 3 Nut, gasket and bolt | 4 Bolt |

- Nest the steering gear in the cover plate, connect the steering column, fixed support, rubber block and steering gear, tight them with bolts. Cover the rubber sleeve on steering gear and fixed it on fixed support with clamps and bolts.

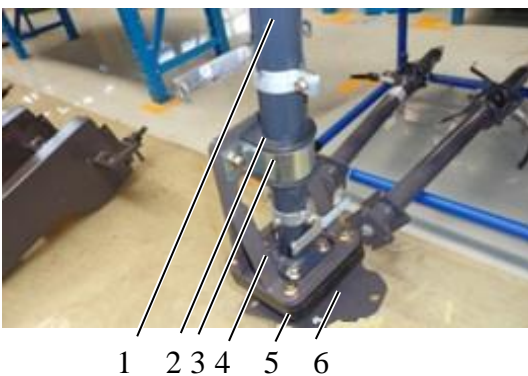
Fig. 6-49

- | | |
|-------------------|-----------------|
| 1 Steering column | 2 Rubber sleeve |
| 3 Pipe clamp | 4 Fixed support |
| 5 Rubber block | 5 Cover plate |



1

Fig. 6-50

1 Bolt

3. Properly place the cross-shaped block into the steering gear, hold up the steering gear and align it with steering column (try to turn the steering wheel left and right gently to align them), fix them with bolts.

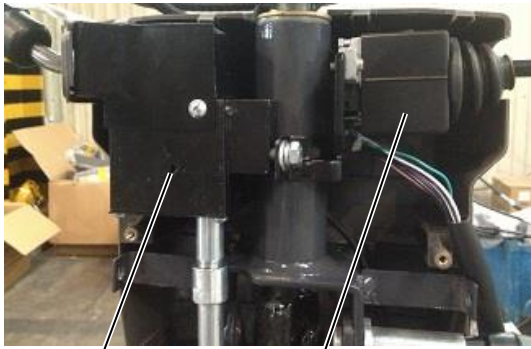

1

2

Fig. 6-51

1 Gear shifting control handle

2 Combination switch

4. Install gear shifting control handle and combination switch.

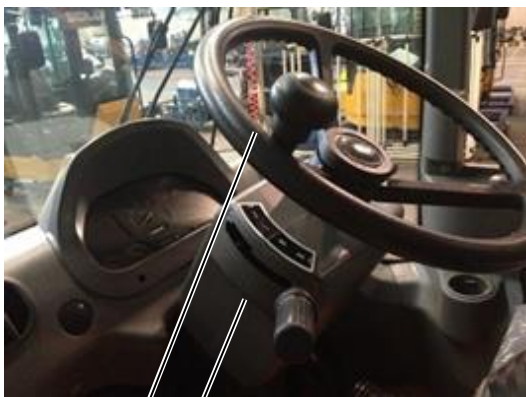

1

2

Fig. 6-52

1 Gear fender apron

2 Steering wheel

5. Install the steering column bottom cover and rubber sleeve, and then install gear fender apron and front and rear covers of steering column. Remove, finally install the steering wheel.

63 Deflation of Steering System

After replacing steering pump, steering gear, priority valve, steering cylinder and the hydraulic pipes in steering circuit, air bleeding must be done by performing the following steps:

1. Park the loader on maintenance position properly, and then open the filling cap of hydraulic oil tank.
2. Run the engine at idle speed for several minutes, do not use any hydraulic function during this process.
3. After the hydraulic oil is fully circulated, turn the steering wheel left and right within a narrow range for several times. Be sure not to let the steering cylinder gets to its stroke end.
4. Keep the engine run at idle, turn the steering wheel gently to let steering cylinders stretch out and draw back in full stroke for 3~5 times to drain the air in the circuit out. If necessary, disconnect the oil inlet or outlet pipe of steering cylinder to get sufficient draining effect. Do not build up hydraulic pressure during air draining.
5. After air draining, set the machine and d working device in standard position, check the oil level and tighten the filling cap.
6. Stop the engine, check and ensure there is no leakage in hydraulic circuit.

64 Instructions for Steering System Pressure Test and Adjustment

641 Pressure Measurement of Steering Hydraulic System

Pressure measuring port of LG936L wheel loader steering system is located on the steering cylinder joints, one on the left and right separately. Normal temperature range: 45°C~55°C.

Put the working device on the ground, pull up parking brake, wedge the tires with wood blocks or rocks. Shut down the engine, operate the operation handle 10 times and turn the steering wheel left and right 5 times to drain the internal oil pressure of the system, and get the SDLG dedicated fault diagnosis toolbox ready. Connect a T-junction (with test connector) to steering cylinder pressure measuring port, and then connect the pressure meter to the test connector with a hose. Start the engine, turn the steering wheel to its extreme position. When the front frame rotates to its extreme position, increase the accelerator gradually, observe the pressure meter and record its stable value, and that is the steering system working pressure. Compare the measured value to standard one, as the circumstances may require, adjust or adopt other measures according to fault diagnosis procedures. Working pressure: 12Mpa.



Fig. 6-53
1 Pressure measuring port



1 2
Fig. 6-54
1 Oil return pipe of priority valve
2 Safety valve

642 Pressure Adjustment of Steering Hydraulic System

Working pressure for steering system is controlled by the built-in safety valve of priority valve. The priority valve of LG936L wheel loader is installed on rear frame left side. The built-in safety valve is installed on the oil return pipe side of priority valve, remove the return pipe to do the adjustment. Loosen the locking nut, rotate the pressure adjusting spring, and turn clockwise to increase the system pressure, while anticlockwise to decrease system pressure.

65 Diagnosis and Solutions for Common Faults of Steering System

Table 6-7

1. Steering hard	1. The built-in check valve of steering gear is damaged and the inlet is blocked.
	2. Steering gear failure, the check valve steel ball is jammed and couldn't reset.
	3. Priority valve LS pipe is twisted together or too long, the damping hole is blocked or oil leakage.
	4. The steering column is damaged and requires larger driving torque.
	5. Interference between steering column and steering gear connecting part, extra axial or radial force is formed and acts on steering gear valve element after assembling.
	6. Low set pressure of priority valve relief valve, or the main valve element is stuck, or the damping hole is blocked.
	7. Low set pressure of safety valve of steering gear combination valves.
	8. Oil return filter is blocked.
	9. The pump is severely worn, whose volume efficiency, output pressure and flow rate can no longer meet system requirement.
	10. Somewhere in the steering circuit is blocked that results in severe throttle.
	11. Main valve element of priority valve is jammed or the main spring rigidity is reduced.
	12. Interference in front axle steering mechanism.
2. Vehicle off tracking	1. Check whether the connecting rod of steering cylinder is loose.
	2. Internal leakage of steering cylinder.
	3. There is large pressure differential between the two tires.
	4. Leakage in one side of bi-directional oil compensation valve or bi-directional overload valve.
	5. Oil contains too much air.

3. Self-steering when steering wheel is in neutral.	1. Check the connecting rod of steering cylinder is loose.
	2. Internal leakage of steering cylinder.
	3. Leakage in one side of bi-directional oil compensation valve or bi-directional overload valve.
	4. Oil contains too much air.
4. Transient steering is not flexible after the machine is just started.	1. The machine is off work for too long, large temperature differential between steering gear components and hydraulic oil.
5. Steering is inaccurate.	1. Too much air in the steering system.
	2. Steering cylinder pin is loose.
	3. Heat shock.
	4. Main valve element of priority valve is jammed.
	5. Oil leakage in steering cylinder.
	6. Low efficiency of steering pump results in unstable pressure.
6. Steering cylinder creeping	1. Too much air in the steering system.
7. Steering wheel can be turned freely, but there is no force feeling or the machine fails to steer.	1. Nuts of steering wheel and steering column fall off.
	2. The connection between steering column central spindle and steering gear valve element is failed.
	3. Low hydraulic oil level.
8. Steering wheel can be turned easily, but the machine doesn't steer or steers slowly.	1. Severe leakage in bi-directional oil compensation valve or bi-directional overload valve.
	2. Severe internal leakage of steering cylinder.
9. Idle motion of steering wheel.	1. Nut of steering wheel is loose.
	2. The connection between steering column and steering gear is severely worn or damaged.
	3. Oil contains too much air.
	4. Leakage in bi-directional oil compensation valve or bi-directional overload valve.
	5. The steering cylinder linkage is damaged or worn (big gap).
	6. Leakage of steering cylinder.

10. Bad return or dragging turning of steering wheel	1. The connection between steering column and steering gear is too tight or interference exists.
	2. Too large return backpressure results in bad return.
	3. Big contamination particle enters into the gap between valve bush and valve element that results in unable to return.
	4. Steering gear spring sheet is damaged or with small rigidity.
11. Components of steering gear is damaged	1. Big and hard contamination particle enters into the gap between stator and rotor.
	2. Severe grind damage.
	3. Pull pin cracked
	4. Heat shock. (50°C differential)
12. Steering wheel trembles or self-rotation	5. Wrong assembly relationship. For reassembly, corresponding spline tooth in universal driving shaft pull pin groove should be aligned to rotor internal spline tooth concave.
	6. Connect the oil inlet pipe to port R or port L, and the steering gear will self-rotate as the motor.
13. Steering wheel and the machine turning in opposite direction	1. Pipe of port L and port R are inversely connected.
14. Steering wheel rebound	1. The built-in check valve of steering gear is damaged



Service Manual

LG936L

Version:0710



7 Frame, Wheels and Working Equipment

CONTENTS

7 Frames, Wheels and Working Equipment	7-1
71 General	7-1
711 Overview of Frame	7-1
712 Overview of Tire	7-2
713 Overview of Working Device	7-2
72 Disassembly and Assembly of Counterweight	7-4
73 Disassembly and Assembly of Working Device	7-5
731 Disassembly and Assembly of Quick-Change Bucket.....	7-5
732 Disassembly and Assembly of Quick-Change Device.....	7-7
733 Disassembly and Assembly of Boom, Connecting Rod and Rocker Arm..	7-8
74 Disassembly and Assembly of Frame Junction	7-15
75 Disassembly and Assembly of Tires	7-20
76 Current Maintenance for Frame, Tires and Working Device	7-21
761 Daily Check	7-21
762 Periodic Maintenance	7-21

7 Frames, Wheels and Working Equipment

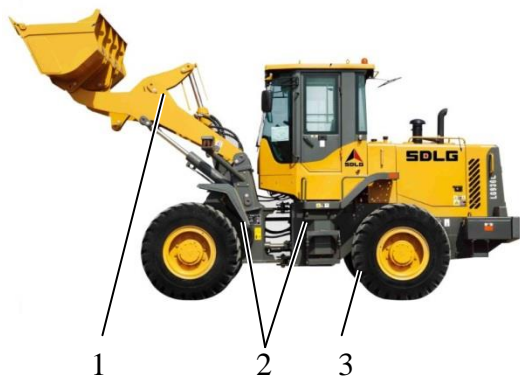

Fig. 7-1

- 1 Working device
2 Frame 3 Tire

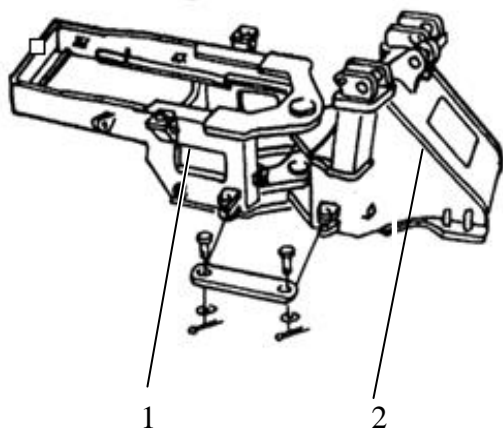

Figure 7-2

- 1 Rear frame 2 Front frame

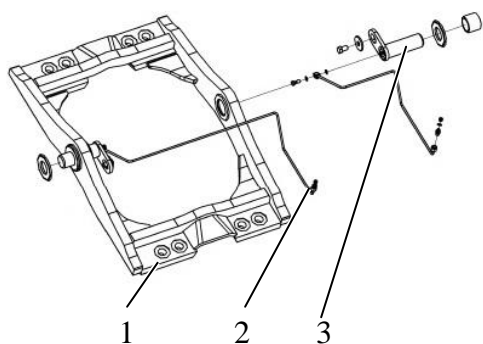

Figure 7-3

- 1 Auxiliary frame
2 Grease filling pipe 3 Pin

71 General

Collectively, frames, tires and working device constitute the tire loader's skeleton, support the whole weight of the loader and the arrangement of other systems are based on them. When reassembling this part, try to ensure the assembly accuracy of each component as far as possible, otherwise service life of the whole machine will be shortened.

711 Overview of Frame

LG936L has adopted the most common articulated frame. Articulated frame consists of front frame, auxiliary frame, hinge pin and rear frame. Articulated frame has the advantages of small turning radius, flexible and can be used in narrow space. Front and rear frame are connected with hinge pin, the frame can turning around the pin under the action of steering cylinder to realize steering.

The auxiliary frame of LG936L is unitary frame with simple and reliable structure, so stability of the machine is significantly improved.

Function of each part:

Front frame: Linked to front axle, mainly support the working device.

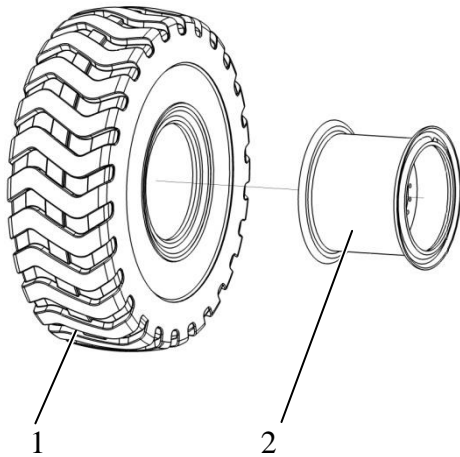
Figure 7-4

1 Tire

2 Rim

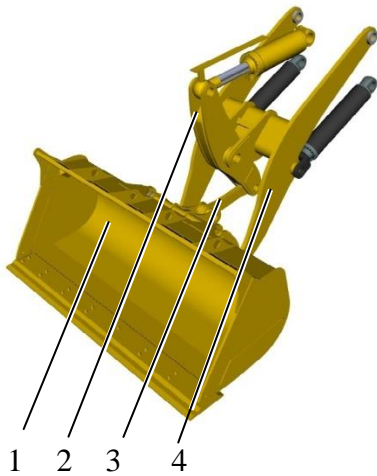
Figure 7-5

1 Bucket

2 Rocker arm

3 Connecting rod

4 Boom

Rear frame: Support engine, speed changer-torque converter assembly, cab and tank.

Hinge pin: Connect the front and rear frame.

Auxiliary frame: Connect the rear frame and rear drive axle, and make the rear drive axle have a certain swing angle.

712 Overview of Tire

The tires not only support the whole weight of the machine, but also serve as a shock absorber, which increases operation comfort.

Different type of tires adapts to different regions, environment and working conditions, choose tires according to actual working condition, and do not select them at will.

713 Overview of Working Device

Working device of wheel loader can be used for various operations, such as material spading and loading. It is generally composed of bucket, boom, rocker arm and connecting rod.

Rear-end of the boom is connected to front frame with a pin, and the front-end is installed with bucket, and the middle part is connected to boom cylinders. When boom cylinder retracts or extends, the boom rotates around the rear-end pin to realize raising and lowering of the bucket. The middle part of rocker arm is connected to boom, and its two ends connect to bucket cylinder and connecting rod respectively. When bucket cylinder retracts or extends, the rocker arm rotates around its middle pin to realize sursumversion and turnover of the bucket.

LG936L working device adopts Z inverted six-bar



Figure 7-6

linkage, this kind of mechanism not only increases the loader's digging-up force, but also good for stability of the bucket, which improves working performance of the loader, and make the loader well adapted to all kinds of working condition, such as spading, lift and unloading, significantly improved the loader' working efficiency.

Working device of LG936L is designed with quick-change mechanism, enable the user replaces with different working tools fast for different working conditions.

72 Disassembly and Assembly of Counterweight

★ ATTENTION

Before dismantling the counterweight, park the loader on even ground and keep steering wheel in neutral, engage parking brake and keep the bucket flat on the ground. It is prohibited to disassemble the loader on uneven ground. Requirements for disassembly and assembly of other parts are the same.

Disassembly of counterweight

1. Connect the counterweight to lifting appliance and remove the fixing bolts of counterweight, hang the counterweight to a safety place.

 Counterweight: 630kg

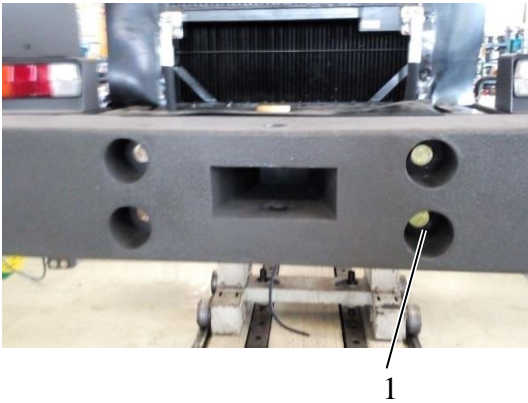

Figure 7-7

1 Counterweight fixing bolt

Assembly of counterweight

1. Hang the counterweight in position and fix it with bolts.

73 Disassembly and Assembly of Working Device

731 Disassembly and Assembly of Quick-Change Bucket



Figure 7-8

Disassembly of quick-change bucket

1. Start the machine and park it to flat, spacious and solid ground, leave some space for reversing, keep the quick-change bucket flat on the ground.
2. Turn the quick-change power switch on.

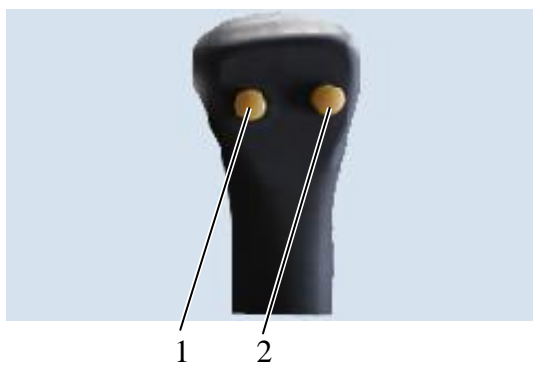

Figure 7-9

- 1 Quick-change disassembling button
- 2 Quick-change assembling button

3. Press down the quick-change disassembling button (the right one) to retract the pin of quick-change device to disconnect the quick-change bucket. As shown in Fig. 7-9.
4. Operate the operation handle to tilt the quick-change device forward slightly (unloading motion), back the machine slowing in the meantime, and then lower the boom until the quick-change device pin is off the bucket hook.
5. Back the machine and operate the handle to pack up the quick-change device and raise the boom.
6. Set the operation handle in neutral, turn the quick-change power switch off and shut down the engine.

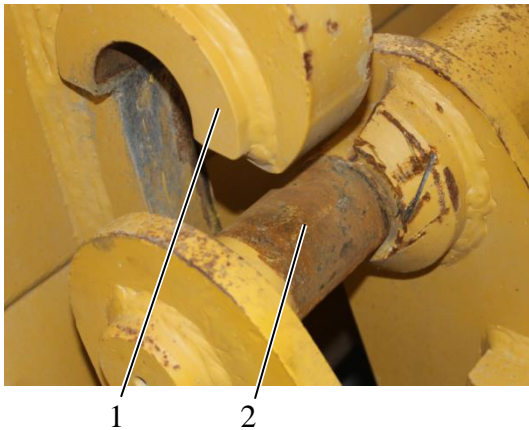

Figure 7-10

- 1 Quick-change bucket hook
- 2 Quick-change device pin

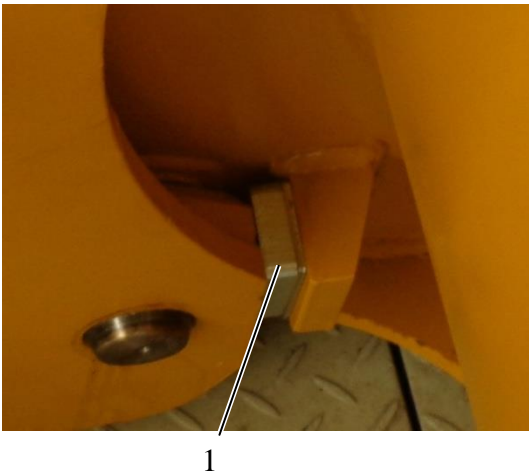

Figure 7-11

- 1 Stop block



Figure 7-12

- 1 Quick-change cylinder pin

Assembly of quick-change bucket

1. Put the quick-change bucket on flat solid ground.
2. Start the machine and drive it slowly, in the meantime operate the handle to adjust the height of quick-change device, to align the quick-change device pin to the bucket hook. As shown in Fig. 7-10.
3. Raise the boom to hook on the pin, continue to raise the boom and drive forward for a short distance slowly to let the quick-change device fully contact the quick-change bucket stop block. As shown in Fig. 7-11.
4. Turn the quick-change power switch on.
5. Press down the quick-change assembling button (the left one). As shown in Fig. 7-9.
6. The quick-change cylinder pin extends to connect with quick-change bucket.
7. Loosen the quick-change assembling button and turn the quick-change power switch off.
8. Set the gear shifting handle in neutral and press parking brake switch, lay down the quick-change bucket. All handles should be in neutral, and then shut down the engine

732 Disassembly and Assembly of Quick-Change Device

Disassembly of quick-change device

1. Remove the hydraulic pipes from the quick-change device.
2. Hang the quick-change device with lifting rope.
3. Put a support under the connecting rod to prevent it falling after taking down the pin that connecting the rod and quick-change device. Falling objects may cause personal injury or damaging the ground.
4. Remove the connecting rod and quick-change connecting pin fixing bolts and knock the pin out with a copper rod.
5. Remove the fixing bolts of boom and quick-change device connecting pin and knock the pin out with a copper rod.
6. Hang the quick-change device to a safety place.

Assembly of quick-change device

1. Start the machine and raise the boom to a certain height (about 30cm to the ground).
2. Clean the internal surface of boom pin hole and inject proper volume grease, install the two O-dust-rings.
3. Hang the quick-change device up and adjust its position to align it to boom connecting pin hole.
4. Connect the quick-change device and boom with pins, and fix them with bolts. Adjust the assembling clearance between boom and quick-change device end face to 0.5~1.5mm

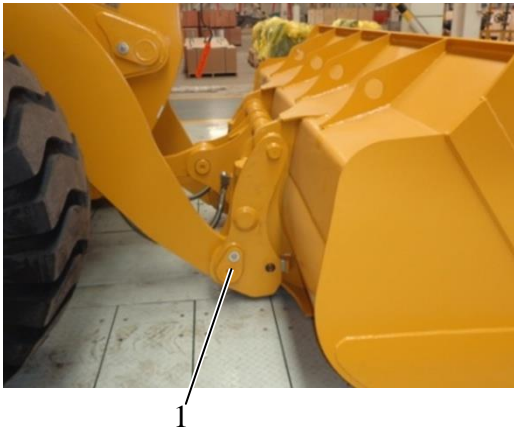

Figure 7-13
1 Pin

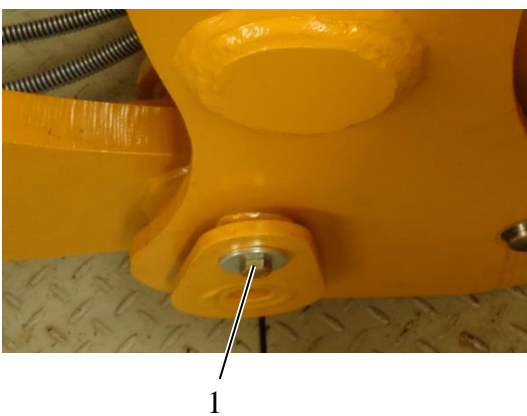

Figure 7-14
1 Pin fixing bolt

with gaskets (quantity and thickness).

5. Put O-ring on two ends of connecting rod hole.
6. Start the machine, hang the connecting rod and operate the bucket cylinder in meantime to align the connecting rod pin hole with quick-change device pin hole.
7. Connect the connecting rod and quick-change device with pin and fix it with bolt. As shown in Fig. 7-14.
8. Inject proper volume grease into pin joint through grease filling port.

733 Disassembly and Assembly of Boom, Connecting Rod and Rocker Arm

Disassembly of connecting rod

1. Start the machine, drive it to flat, spacious and solid ground, and stop the machine after adjusting. Put the bucket on ground and set all control handles in neutral, press the parking brake switch and shut down the engine, wedge the tires with wood blocks.
2. Hang the connecting rod to-be-disconnect end with lifting appliance to prevent the rod falling after taking down the pin. Falling objects may cause personal injury or damaging the ground.
3. Remove connecting rod and quick-change device connecting pin fixing bolts and knock the pin out with copper rod.
4. Put down the connecting rod and remove the lifting rope, hang the other end with the rope.
5. Remove connecting rod and rocker arm



Figure 7-15
1 Connecting rod

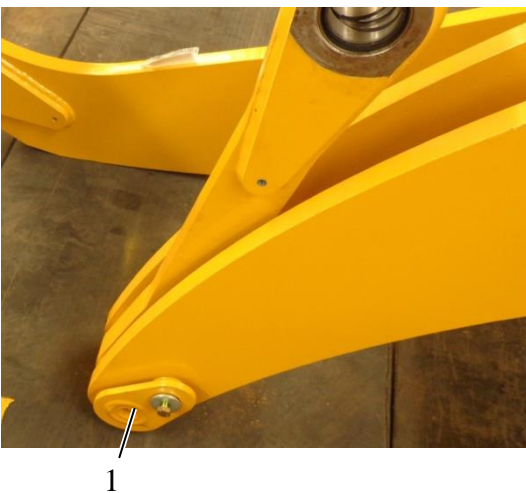

Figure 7-16
1 Pin

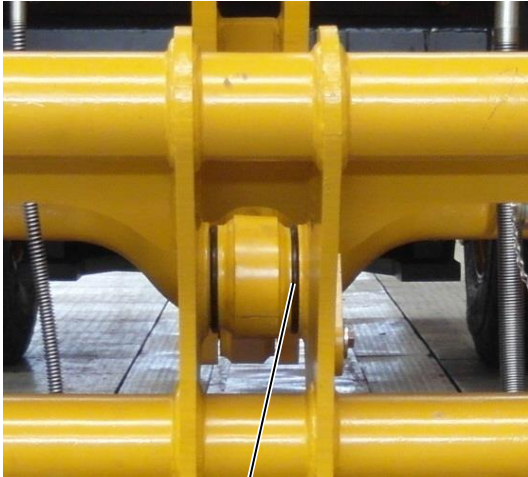

Figure 7-17
1 O-ring



Figure 7-18
1 Lifting rope

connecting pin fixing bolt. As shown in Fig. 7-16.

6. Knock the pin out with copper rod and hang the connecting rod away.

Assembly of connecting rod

1. Clean the internal surface pin holes and inject proper volume grease to each hole.
2. Connect one end of connecting rod with lifting rope, lift the rod up.
3. Put O-ring on fitting faces between connecting rod and rocker arm, one for each. Connect the rod to rocker arm with pin.
4. Tighten the pin fixing bolt.
5. Put O-ring on fitting faces between connecting rod and quick-change device, one for each. As shown in Fig. 7-17.
6. Adjust the connecting rod and operate bucket cylinder to align the connecting rod pin hole with quick-change device pin hole.
7. Connect the rod to quick-change device with pin and fix the pin with bolt.
8. Inject proper volume grease into pin joint through grease filling port.

Disassembly of Rocker Arm

1. Hang the bucket cylinder with lifting rope. Preload the hoisting rope to prevent the steering cylinder from falling down when removing the pin.

 Steering cylinder

2. Remove the fixing bolt of bucket cylinder and rocker arm connecting pin, knock the pin out with copper rod.



Figure 7-19
1 Wood block

3. Lift the steering cylinder and put a wood block under steering cylinder to support it. As shown in in Fig. 7-19.



Figure 7-20
1 Lifting rope

4. Hang the arm with rope.



Figure 7-21
1 Bolt

5. Remove the fixing bolt of pin between connecting rod and rocker arm. Knock the pin out with copper rod, and take down the O-ring.



Figure 7-22
1 Bolt

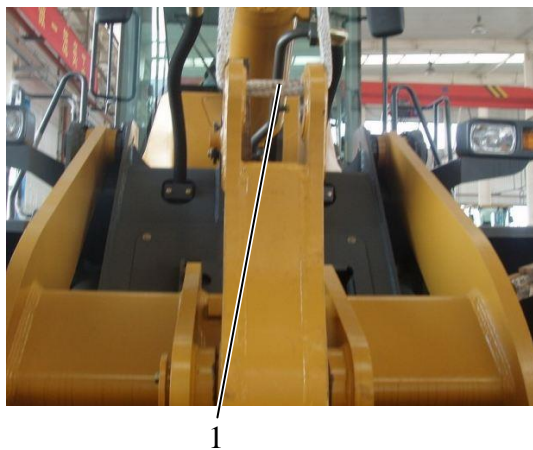

Figure 7-23
1 Lifting rope

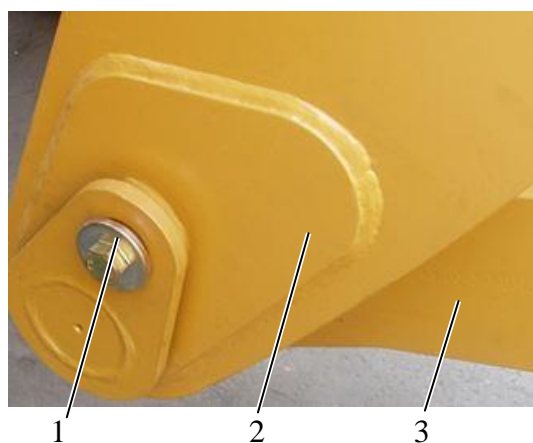

Figure 7-24
1 Bolt
2 Rocker arm
3 Connecting rod

6. Remove the fixing bolt of pin between arm and boom, Knock the pin out with copper rod.
7. Put the arm on clean cushion.

Assembly of Rocker Arm

1. Clean the internal surface of rocker arm middle hole and inject proper volume grease to the hole.
2. Install the freezed shaft sleeve into the pin hole, make sure the distances between the sleeve and the two ends of hole are equal.
3. Install O-dust-ring on both ends of the shaft sleeve.
4. Hang the rocker arm with lifting rope.
5. Clean the internal surface of connecting rod pin hole and inject proper volume grease to the hole.
6. Install the freezed shaft sleeve into the pin hole, make sure the distances between the sleeve and the two ends of hole are equal.
7. Install O-dust-ring on both ends of the shaft sleeve.
8. Connect the connecting rod and rocker arm with pin and fix the pin with rod.

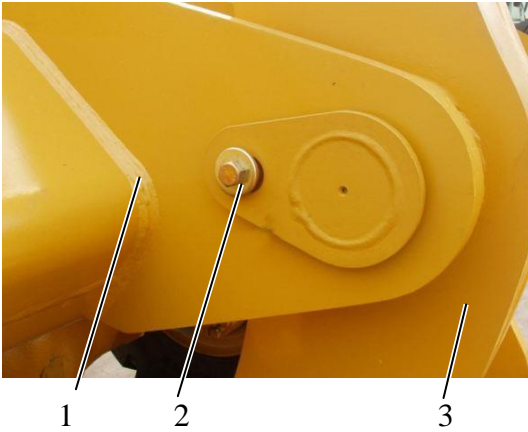

Figure 7-25

1 Boom 2 Bolt 3 Rocker arm

9. Align the two pin holes of the rocker arm and boom. Mount the arm to the boom with pin and fix the pin with bolt.
10. Keep the arm stable and remove the lifting rope from rocker arm pin hole.

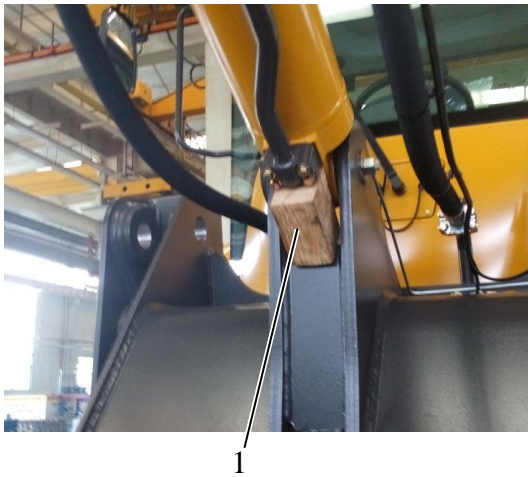

Figure 7-26

1 Wood block

11. Hang the bucket cylinder rod end with lifting rope and remove the wood block.
12. Start the engine and adjust the stroke of piston rod. With the help of hoisting rope, align the pin holes of bucket cylinder and rocker arm.
13. Use a pin connecting the bucket cylinder to arm. Put gaskets in the connecting end. Choose proper type and installing position of gasket to ensure the installing clearance between 0.5~1.5mm.
14. Fix the pin on rocker arm with bolt.
15. Inject proper volume grease into pin joint through grease filling port.



1

Figure 7-27
1 Wood block

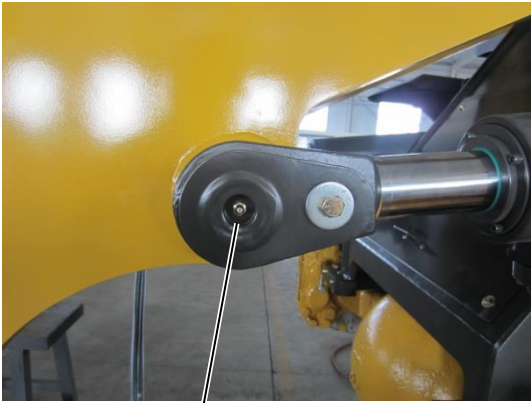

1

Figure 7-28
1 Pin



1

2

Figure 7-29
1 Grease pipe
2 Pin

Disassembly of boom

1. Remove the rocker arm, refer Page 7-9 **Disassembly of rocker arm.**
2. Remove the quick-change device, refer Page 7-7 **Disassembly of quick-change device.**
3. Start the engine, raise the boom to horizontal position and put wood block under the boom.
4. Hang the boom with lifting rope, as long as the rope is tensioned.
5. Remove fixing bolt of pin which connects boom and boom cylinder. Knock out the pin lightly and take away.
6. Remove fixing bolt of pin that connecting front frame and boom. Knock the pin out lightly and take it away. As shown in fig 7-29.
7. Hang the boom away and put it down.

Assembly of boom

1. Clean the internal surface of boom pin hole and apply proper volume grease.
2. Press-in two freezed shaft sleeves into the pin hole (between boom and front frame), Install O-dust-ring on both ends of the shaft sleeve.

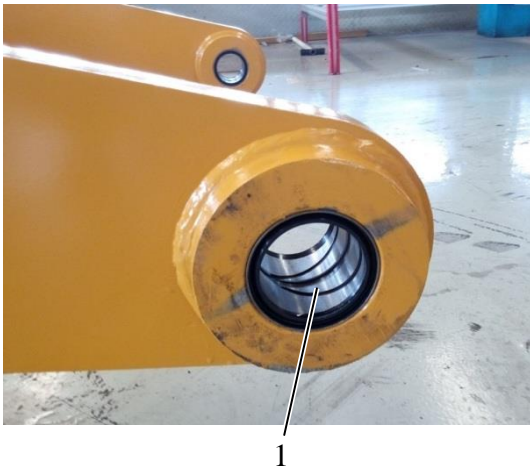

Figure 7-30
1 Shaft sleeve

3. Hang the boom with lifting rope, approach the front frame slowly, align the relevant holes in the boom and front frame.
4. Connect front frame and boom with pin and fix the pin with bolt. Adjust the gaskets to keep the clearance between boom and front frame end face within 0.5~1.5mm.



Figure 7-31
1 Boom

5. Start the engine, control the stroke of boom cylinder to adjust the height of boom. Align the pin holes of boom and boom cylinder.
6. Connect boom cylinder and boom with pin and fix the pin with bolt.

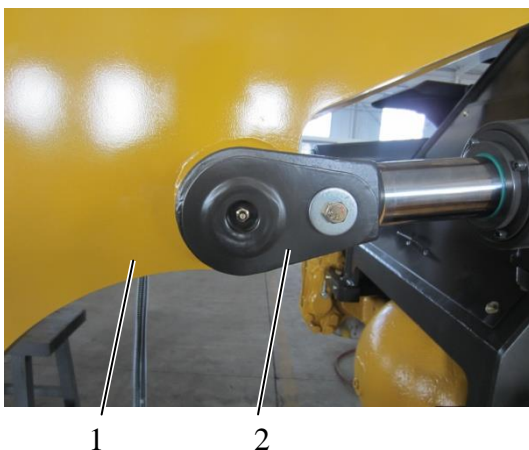

Figure 7-32
1 Boom 2 Boom cylinder

74 Disassembly and Assembly of Frame Junction

Disassembly of frame junction

1. Park the machine on the solid and flat ground.
2. Put the bucket on proper spacer bush, and make sure it can move forward.
3. Step the brake pedal repeatedly (about 40 times) to release the pressure in the braking system.
4. Move back and forth the pilot operation handle repeatedly to release the pressure of hydraulic system.
5. Turn off the power switch of battery.
6. Put blocks under front and back of rear tires to prevent the loader moving. As shown in Fig. 7-34.
7. Disconnect the intermediate transmission shaft.



1

Figure 7-33

1 Power switch of battery



1

Figure 7-34

1 Wood block



1

Figure 7-35

1 Intermediate transmission shaft

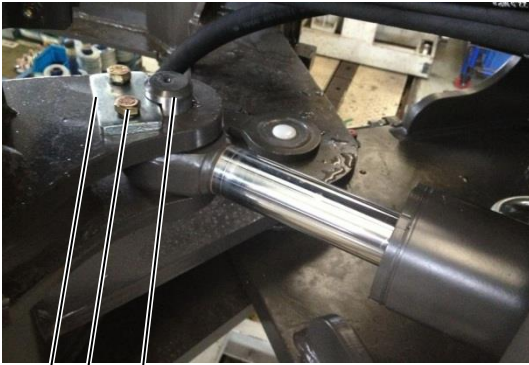

Figure 7-36
1 Cardboard 2 Bolt 3 Pin



Figure 7-37
1 Slotted nut

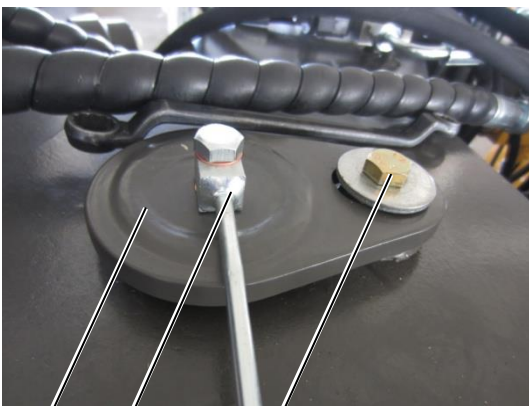

Figure 7-38
1 Pin 2 Grease pipe
3 Bolt

8. Remove the fixing bolt of the steering cylinder front pin, take down the bolt and cardboard, and press the pin out. As shown in Fig. 7-36.
9. Disconnect the hydraulic pipes between rear and front frame.
10. Use two single jacks to support the rear part of the rear frame.

★ATTENTION

Due to rear part of the rear frame is heavy, the move is designed to prevent the frame tilting backward.

11. Put support under front part of the rear frame and rear part of the front frame.
12. Remove the cotter and slotted nut.
13. Knock the lower hinge pin upward to remove it, cool this pin or new pin in the refrigerator or similar device.

★ATTENTION

Knock the pin gently to prevent damaging it.

14. Remove lubricating pipe and fixing bolt of upper pin, and knock the pin out with copper rod, cool this pin or new pin in the refrigerator or similar device. As shown in Fig. 7-38.
15. Hang front frame away with lifting appliance.

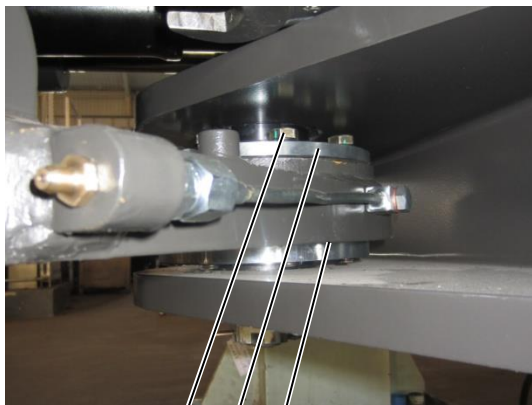

1 2 3

Figure 7-39

1 Bolt 2 Upper flange plate
3 Lower flange plate

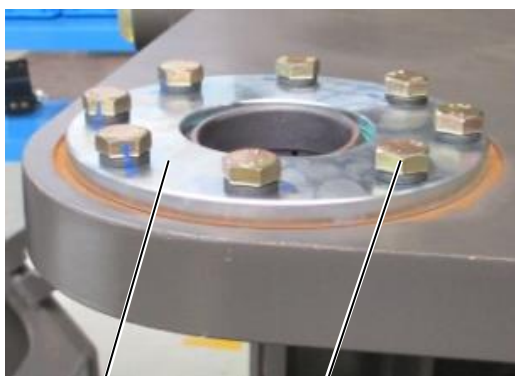

1 2

Figure 7-40

1 Flange plate 2 Bolt



Figure 7-41

16. Mark the position of flange plate. Remove the flange plate cover, bush and adjusting gasket. As shown in Fig. 7-30.
17. Remove the seal ring and clean the flange plate. Do not wash off the mark.

18. Remove the flange plate and bearing.

Assembly of frame junction

1. Clean the internal surface of pin holes and smear proper volume grease. Install the two bearings and spacer sleeve. When installing, the narrow end of two bearing outer ring should be face-to-face, and put the spacer sleeve between them. Press the bearing-sleeve assembly in to the pin hole.

★ ATTENTION

Antifriction bearing should be freezed for 4 hours before assembling.

2. Install the flange plate with four cross-placed bolts. Pre-tighten the bolts to ensure there is no gap between lower bearing lower end face and lower flange plate upper end face. Then take down the two flange plates.

★ ATTENTION

The move is ensure there is no gap between lower bearing lower end face and lower flange plate upper end face, not official assembly.



1

Figure 7-42
1 Bush

3. Use a depth vernier gauge to measure distance A between upper bearing upper end face and upper pin hole upper end face, and the first floor depth of the flange plate B, install gaskets on the bottom of upper cover, total thickness of gaskets is C. After assembly, B+C-A is axial displacement of bearing inner ring, and ensure it is within 0.1~0.2mm.
4. Install flange plate. Tighten the bolts in diagonal way.

 Nm Torque: 90±15Nm

★ ATTENTION

Align the mark when installing the flange plate.

5. Apply proper volume grease on the bush and press it into the flange plate, then install the dust ring.
6. Clean the upper pin hole and install upper bearings.
7. Install flange plate. Tighten the bolts in the diagonal way.

 Nm Torque: 90±15Nm

8. Hang the front frame in position with lifting appliance.

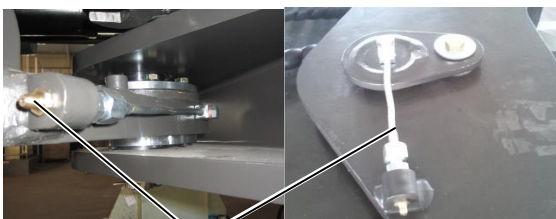

1

Figure 7-43
1 Grease pipe

9. Install the lower hinge pin.
10. Install the upper hinge pin.
11. Install the upper and lower grease pipe and add grease. As shown in fig 7-43.

75 Disassembly and Assembly of Tires

★ ATTENTION

Before the disassembly, it is required to support the to-be-disassembled tire with holder, the tire should be 5~15cm off the ground.

Disassembly of tires

1. Remove the rim nuts.
2. Hang the tire to safety place with lifting appliance.

Assembly of tire

1. Hang the tire in position with lifting appliance.
2. Tighten the rim nuts in diagonal way.

 Nm Torque: $310 \pm 45 \text{N} \cdot \text{m}$



1

Figure 7-44
1 Rim nut

76 Current Maintenance for Frame, Tires and Working Device

761 Daily Check



1

Figure 7-45
1 Grease cup

- After long time operation of shoveling and transporting stones, check whether working device and frames are damaged, check whether the connecting bolts and nuts are loose or damaged.
- Check whether the rim nuts and swing bracket nuts are loose every time before operation, check whether there is air leakage in tires.

762 Periodic Maintenance

- Check lubricating condition of all hinge joints, add specified grease as required.
- Check the wear condition and clearance between pin and pin bush of all hinge joints, replace them if necessary.
- Check rim torque is in prescribed limit, adjust timely if out of range.
- Check whether tire pressure is in required range.
- Check whether the frames and working device are cracked and deformed.



Service Manual

LG936L

Version:0810



8 Cab and Cover Systems

CONTENTS

8 Cab and Cover Systems	1
81 Cab Description	1
811 General.....	1
812 Cab External Declaration	1
813 Cab Interior Decoration Declaration	2
82 A/C System Description	4
821 General.....	4
822 System Description.....	5
83 Disassembly and Assembly of Cab Assembly	8
831 Disassembly of Cab Assembly	8
832 Assembly of Cab Assembly	12
833 Disassembly and Assembly of Seat.....	18
834 Disassembly of Operation Box.....	19
835 Assembly of Operation Box	21
84 Disassembly and Assembly of Engine Hood	24
841 Disassembly of Engine Hood	24
842 Assembly of Engine hood	26
85 Disassembly of Left and Right Platform Assembly	29
851 Disassembly of Platform Assembly	29
852 Assembly of Platform Assembly	30
86 Disassembly and Assembly of A/C System	32
861 Disassembly of Evaporator Assembly	32
862 Assembly of Evaporator Assembly	34
863 Replacement of Evaporator Components.....	37
864 Replacement of Condenser Fan.....	42
865 Replacement of Liquid Reservoir.....	43
866 Replacement of Compressor Components	43
867 Draining and Filling of Refrigerant.....	45
87 Diagnosis and Solutions for Common Faults of A/C System	49
871 Regular Checking Items	49
872 Non-Refrigeration Fault Analysis	50

873 Insufficient Refrigerating Fault Analysis	50
874 Non-Heating Fault Analysis	51
875 Other Fault Analysis	51

8 Cab and Cover Systems

81 Cab Description

811 General

LG936L cab has the advantages of safety, comfort and large space, not only looks luxury, but also can fully satisfy the operator's requirements for comfort.



1

Fig. 8-1
1 Cab

812 Cab External Declaration

The cab is fixed on frame with four dampers. The dampers can significantly reduce the noise and vibration, improve driving comfort.

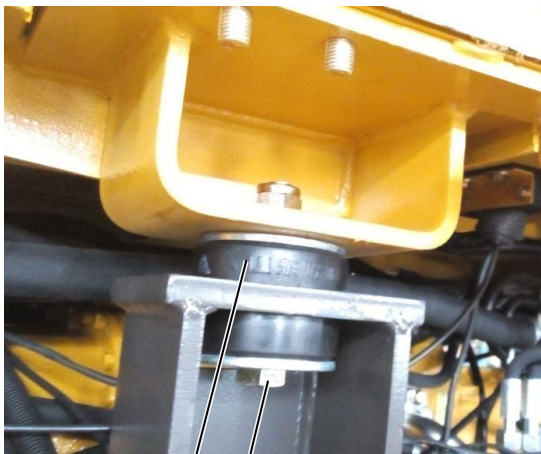

1 2

Fig. 8-2
1 Damper 2 Bolt

813 Cab Interior Decoration Declaration

The cab interior is commodious, operating handle is located in the right hand side, and dashboard is located in the front side of the cab.



Fig. 8-3 Cab

1 Gear shifting control handle

2 Steering wheel

3 Left foot brake pedal

4 Seat

5 Instrument panel

6 Right foot brake pedal

7 Accelerator pedal

8 Pilot control handle

9 Parking brake switch

10 Rocker switch

Rocker switch

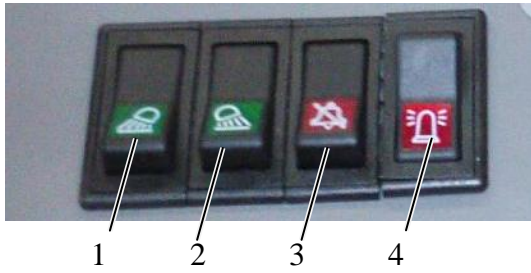

Fig. 8-4

- 1 Front lamp switch
- 2 Rear lamp switch
- 3 Mute switch
- 4 Top alarm lamp switch

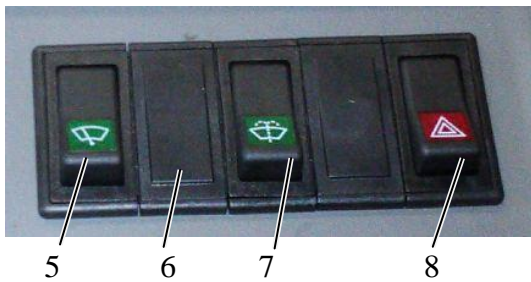

Fig. 8-5

- 5 Wiper switch
- 6 Cover board
- 7 Sprayer switch
- 8 Alarm lamp switch

82 A/C System Description

821 General

LG936L A/C system consists of compressor, evaporator assembly, condenser assembly, receiver-drier, rubber hoses and control panel.

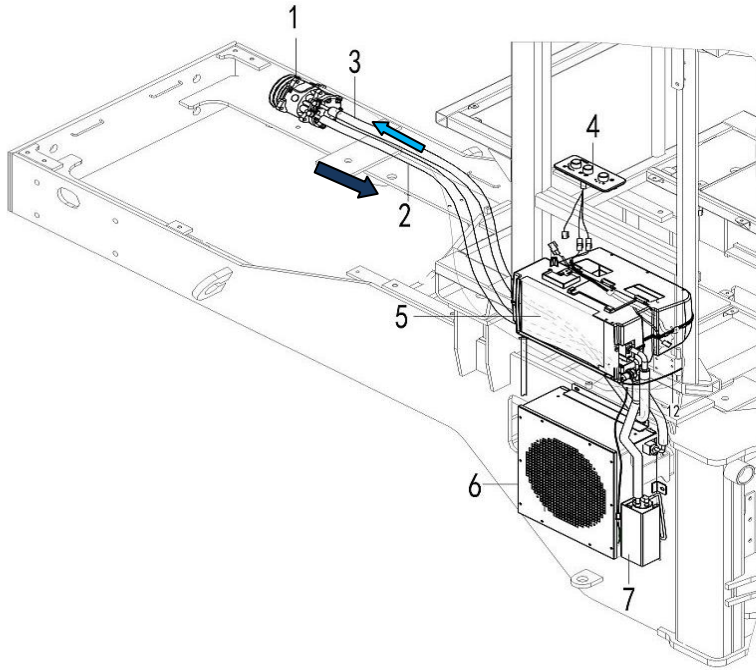

Fig. 8-6

- | | | |
|-----------------|--------------------------------|--|
| 1 Compressor | 2 Compressor to condenser pipe | 3 Evaporator to compressor pipe |
| 4 Control panel | 5 Evaporator assembly | 6 Condenser assembly 7 Receiver-drier |

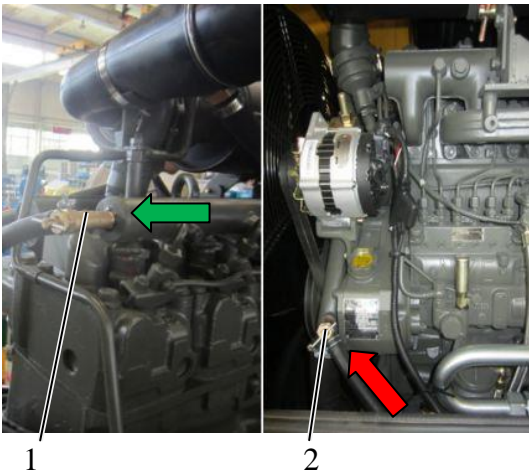

Fig. 8-7

- 1 Engine water outlet valve
- 1 Engine water return valve

822 System Description

LG936L A/C system consists of refrigerating system, heating system, ventilating system and pressure control system.

The loader A/C system is equipped with two filters: Fresh air filter and return air filter. Fresh air filter is used to filter out particles in outdoor inlet air, return air filter is used to filter out particles in indoor recycling air. Fresh air inlet on-off is controlled by the motor in ventilation unit, its control switch is located on right side panel in the cab.

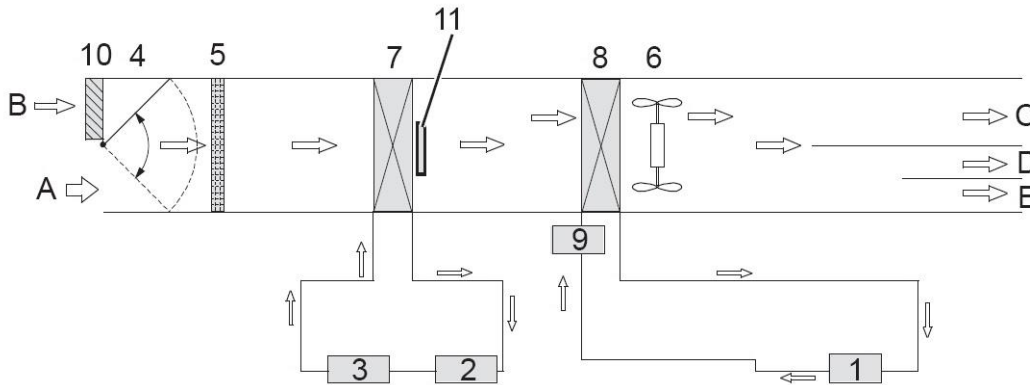

Fig 8-8

- | | | | |
|---------------------|----------------------------|-------------------------------------|-----------------------|
| 1 Engine | 2 Air condition compressor | 3 condenser | 4 Recycling air door |
| 5 Return air filter | 6 Fan motor | 7 Evaporator (with expansion valve) | |
| 8 Fan heater | 9 Refrigerant rate valve | 10 Fresh air filter | 11 Temperature sensor |

The fan absorbs air into the cab through inlet port, and then the air goes through a replaceable fresh air filter, and then passes the air return filter. After the filtering, the air flows into refrigerator core, then the heater core, finally diffuses into the cab.

There are three option switches on the control panel. Cab temperature is electrically controlled by temperature controller, by control refrigerant flow control valve the refrigerant flow rate in evaporator is changeable. Fresh air change-over switch controls recycling air amount, turn this switch right, fresh air from outdoor will be sucked in through filters.

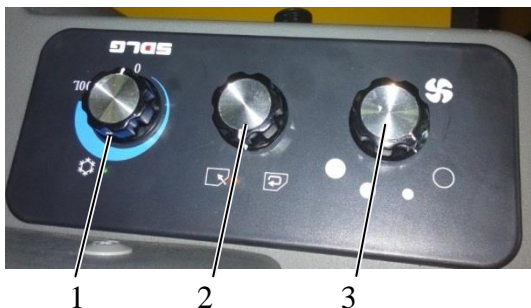
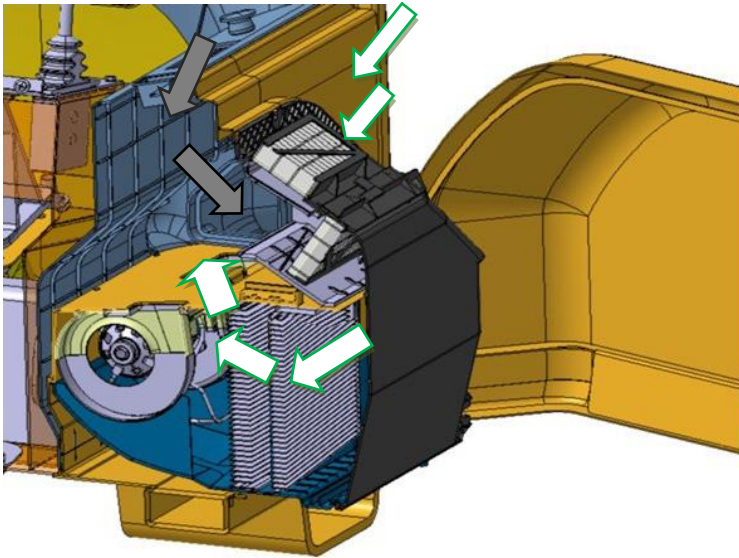

Fig. 8-9

- | | | |
|---------------------|--------------------------------|------------------------------|
| 1 Air volume switch | 2 Fresh air change-over switch | 3 Temperature control switch |
|---------------------|--------------------------------|------------------------------|



-  : Fresh air
 : Recycling air

Fig. 8-10

Refrigerating system of the loader is used for refrigerating the air in the cab or fresh air from outside to lower the temperature in the cab. The operating instructions are as follows:

1. Start the engine;
2. Turn on the power and air volume switches, and then turn the temperature control switch to “COOL” position, indicator light will be on, the refrigerating process starts.
3. Turn the air volume switch; choose between low speed, intermediate speed and high speed, to get three different air volumes.
4. When the temperature is reduced to set temperature, rotate the temperature control switch anticlockwise until the indicator light goes out and the compressor stops working, and the indoor temperature is the set value. When the indoor temperature is above this temperature, indicator light will on, the compressor will start automatically and the system begins to cool; When the indoor temperature is below this temperature, indicator light goes out and the system stops working.
5. When use the air condition, please don't turn the temperature control switch to “COOL” position and turn the wind switch to low speed at the same time. Because this will cause evaporator frosting and influence the refrigerant performance.

Heating system of the loader uses the heat energy of the cooling liquid. It introduces the cooling liquid of the diesel engine to the radiator in the cab and uses the blower to blow the heated air to the interior of the cab. At the same time, the heating system cleans the frost and fog on the front window. Heating system operating instructions:

1. Turn the temperature control switch to “O” or “OFF” position (off state);
2. Start the engine and open the hot water valve;
3. Turn on the air volume switch, select the mode and choose the required wind speed.

Ventilation system of the loader includes natural ventilation and forced ventilation. The natural ventilation uses the wind pressure produced outside the cab when the loader drives to ventilate; forced ventilation uses the blower to blow the wind outside into the cab.

Pressure system of the loader adopts the high-low pressure switch control. When the pressure of the A/C system is abnormal because of the lack of refrigerant or too high pressure, the compressor will be switched off to protect the A/C system.

Refrigerating fluid for air condition is R-134a (Freon-free environmental refrigerant).

★ATTENTION

When refrigerating in summer, please close the hot water valve. When heating in winter, please close the temperature control switch.

For quick defrosting in cold days, turn on the temperature control switch, utilize the dry air produced under mixing effect of air condition and air heater to defrost.

83 Disassembly and Assembly of Cab Assembly

831 Disassembly of Cab Assembly

Tool: 2m lifting rope.

1. Before the disassembly, lift the cab until the lifting rope is neither loose nor too tight.
2. Disconnect steering gear from cab, do without disconnecting the pipes.

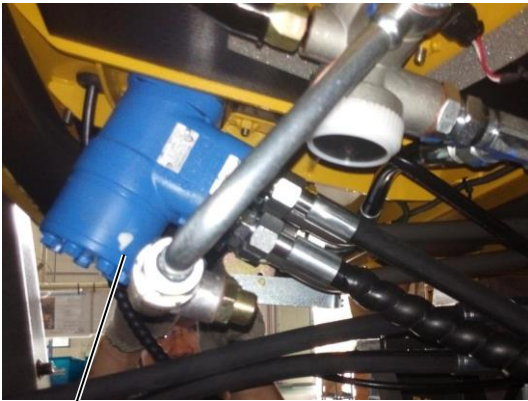

1

Fig. 8-11

1 Steering gear



1

Fig. 8-12

1 Foot brake valve



1

Fig. 8-13

1 Air condition

3. Remove the pipes that connected with foot brake valves, note that there are two foot brake valves, each on left and right sides.

4. Remove the air condition. For details, refer to Page 8-32.



1

Fig. 8-14
1 Pilot control handle

5. Disassemble the pilot valve and operation box.
Refer to Page 8-19 for details.



1

Fig. 8-15
1 Platform

6. Disassemble the platform assembly, refer to
Page 8-29 for details.



1

2

Fig. 8-16
1 Bolt 2 Board

7. Remove the board on both sides of the cab.



1

Fig. 8-17
1 Grounding wire

8. Disconnect the cab grounding wire that connected to rear frame.



1

Fig. 8-18
1 Rear frame wiring harness connector

9. Disconnect the wiring harness between cab and rear frame (at the bottom of cab).



1

Fig. 8-19
1 Front frame wiring harness connector

10. Disconnect the connector between front frame wiring harness and cab wiring harness (at the bottom of front frame).

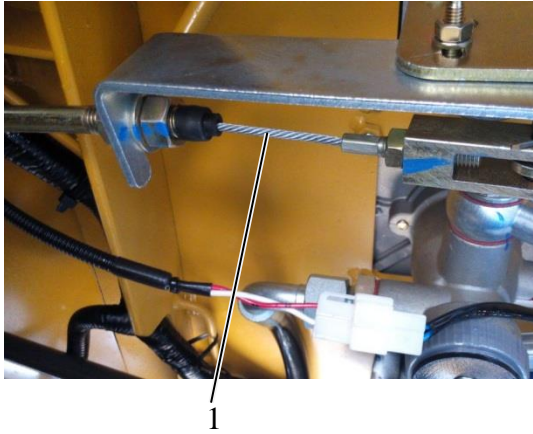

Fig. 8-20
1 Engine accelerator control wire

11. Disconnect the engine accelerator control wire.

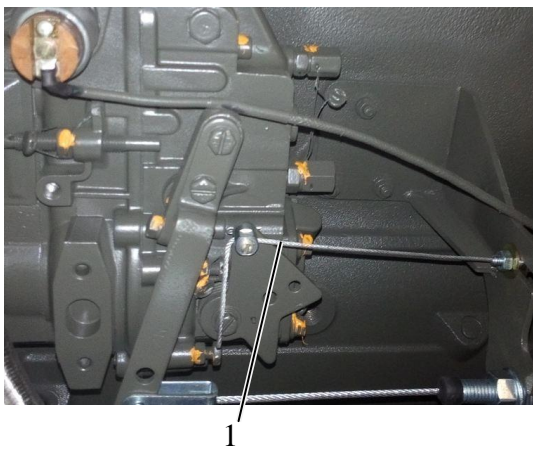

Fig. 8-21
1 Engine flameout wire

12. Disconnect the engine flameout wire.

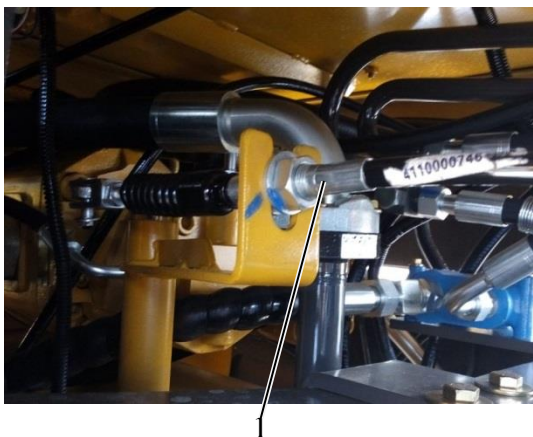

Fig. 8-22
1 Gear shifting control flexible shaft

13. Disconnect the gear shifting control flexible shaft.

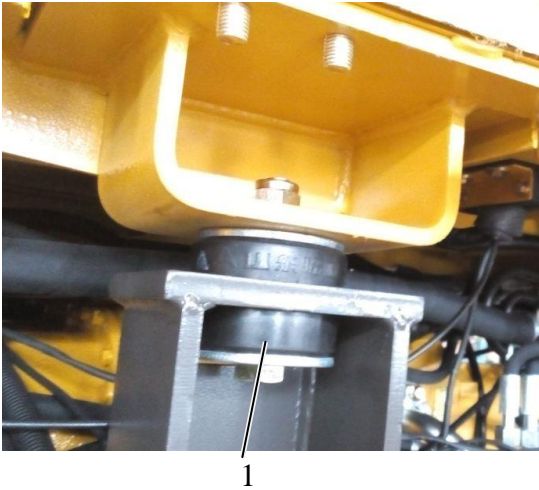

Fig. 8-23
1 Bolt

14. Remove the four connecting bolts of cab.



Fig. 8-24
1 Cab

15. Hang down the cab with lifting rope and put it on the cab support.

★ **ATTENTION**

Before lifting up, check and ensure all pipes and wiring harnesses that connected to cab are disconnected. Keep the cab stable during lifting.



Fig. 8-26
1 Lifting rope

832 Assembly of Cab Assembly

Instrument: 2m lifting rope.

1. As shown in Figure 8-26, lift up the cab with lifting rope and put it on rear frame, do not crash the pipes and wiring harnesses.

★ **ATTENTION**

During lifting, keep the cab balanced to align installing holes, don't crash the hydraulic rubber hoses and wiring harnesses. When putting the cab down, keep it stable.

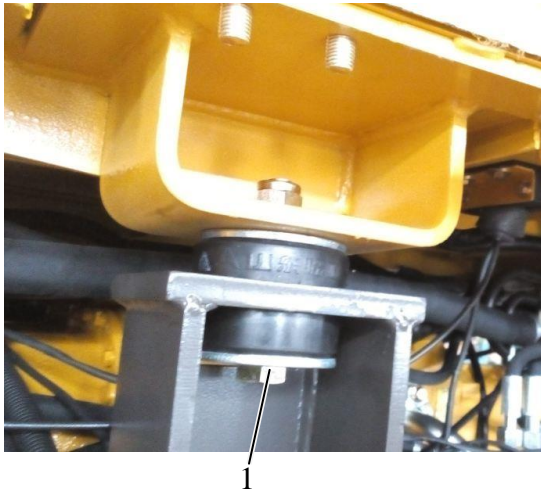

Fig. 8-26
1 Bolt

2. Install the four dampers with bolts.

 Nm 120~200Nm



Fig. 8-27
1 Pilot control handle

3. Connect the pilot control mechanism.

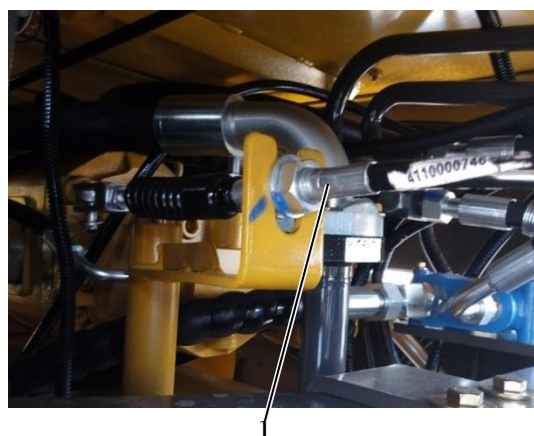

Fig. 8-28
1 Gear shifting control flexible shaft

4. Connect the gear shifting control flexible shaft.

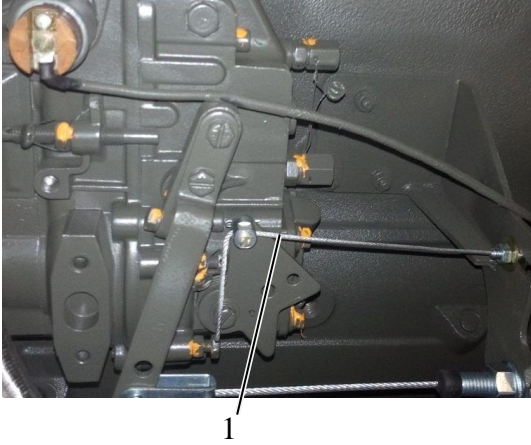

Fig. 8-29
1 Engine flameout wire

5. Connect the engine flameout wire.

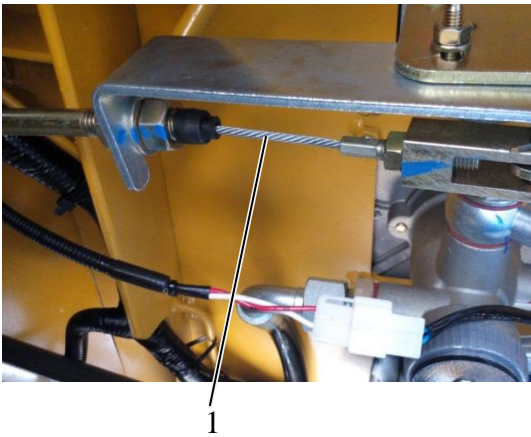

Fig. 8-30
1 Engine accelerator control wire

6. Connect the engine accelerator control wire.

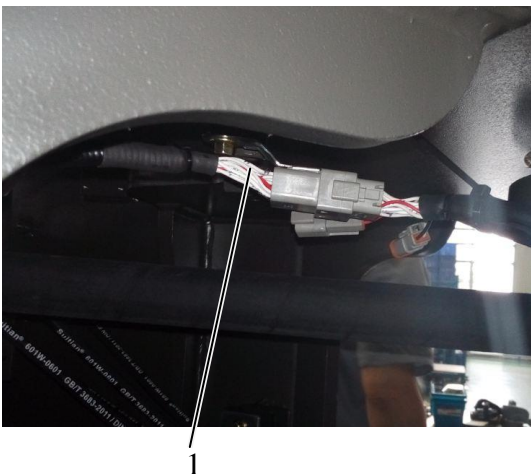

Fig. 8-31
1 Front frame wiring harness connector

7. Connect the connector between front frame wiring harness and cab wiring harness (at the bottom of front frame).



1

Fig. 8-32

1 Rear frame wiring harness connector

8. Connect the rear frame wiring harness connector to cab wiring harness connector (at the bottom of cab).

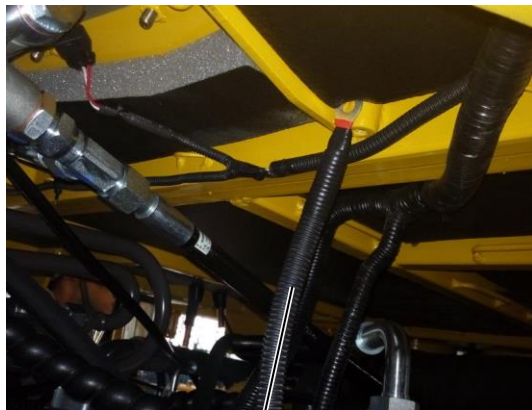

1

Fig. 8-33

1 Grounding wiring harness

9. Connect the cab grounding wire that connected to rear frame.



1

Fig. 8-34

1 Steering gear

10. Connect the steering gear to cab.

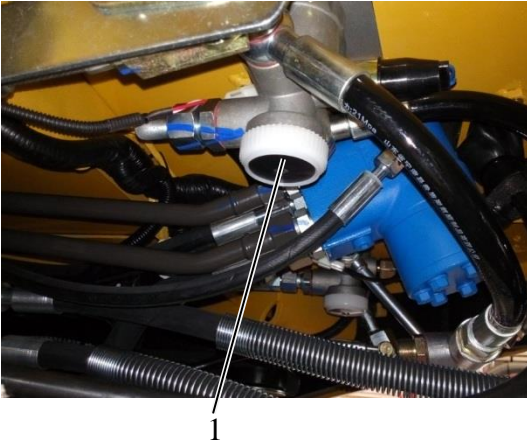

Fig. 8-35
1 Foot brake valve

11. Connect the pipes of left and right foot brake valves.



Fig. 8-36
1 Air condition

12. Install the air condition, refer to Page 8-32.

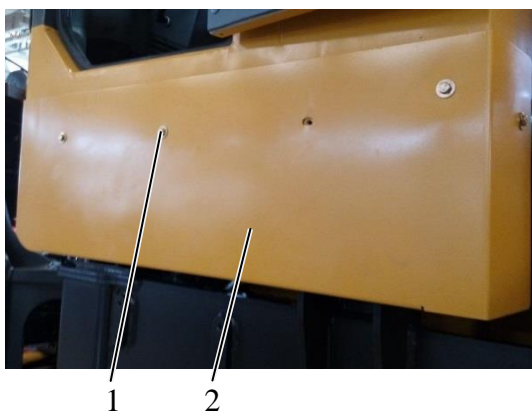

Fig. 8-37
1 Bolt 2 Board

13. Install the cab side boards.



1

Fig. 8-38
1 Platform

14. Install the platform, refer to Page 8-30.

833 Disassembly and Assembly of Seat

Instrument: 2m lifting rope

★ATTENTION

If discovered that the seat is damaged during use and affecting the operator's comfort and safety, be sure to replace it.

1. Remove the bolts that used to connect seat to seat support.

2. Hang the seat out of the cab with lifting rope.

3. Replace the old seat with a new one and fix it with bolts



Fig. 8-39
1 Bolt

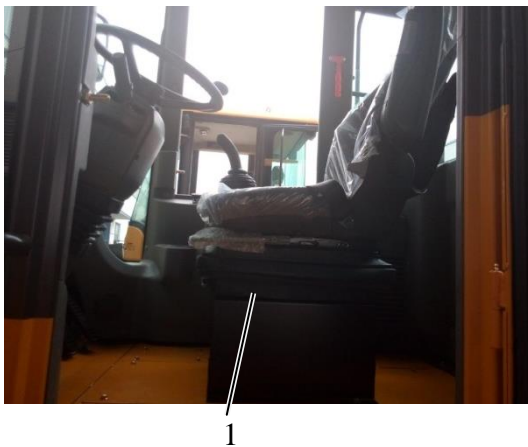

Fig. 8-40
1 Seat



Fig. 8-41
1 Bolt

834 Disassembly of Operation Box

1. It is optional to remove the seat first for the convenience of operation box disassembly. Refer to Page 8-18.



Fig. 8-42
1 Operation box



Fig. 8-43
1 Upper cover of operation box
2 Bolt

2. Remove the fixing screws of operation box.



Fig. 8-44
1 Shield of operation box
2 Bolt

3. Disassemble the peripheral shield. And disassemble the bolts shown in Fig 8-44.

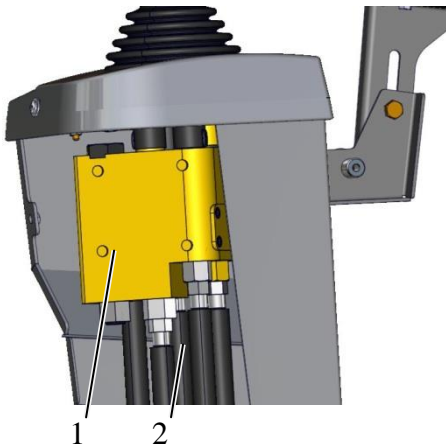

Fig. 8-45
1 Pilot valve
2 Hydraulic oil pipe

4. Remove the fixing clamp of pilot oil pipe and sponge at the bottom of operation box.

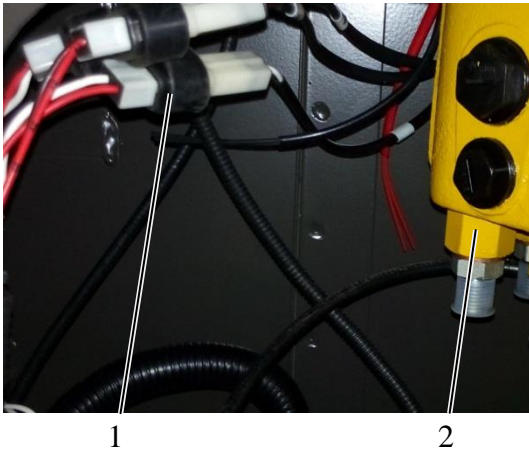

Fig. 8-46
1 Wiring harness connector
2 Pilot valve

5. Disconnect the wiring harnesses of pilot control mechanism.

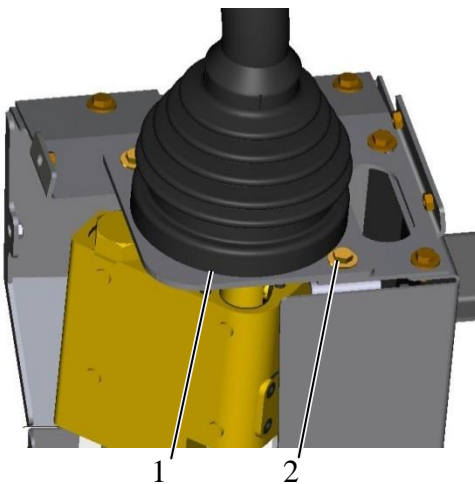
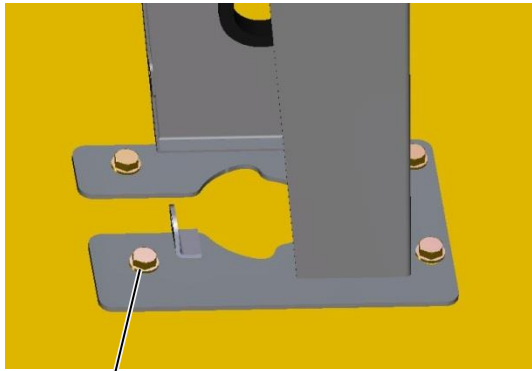
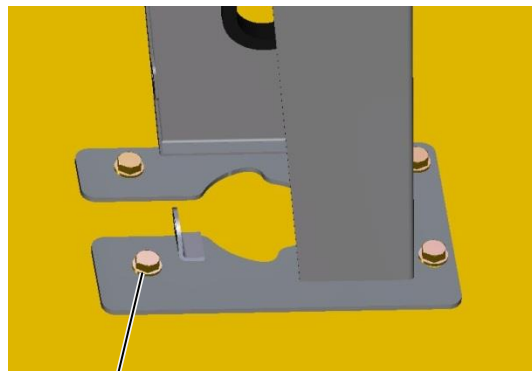

Fig. 8-47
1 Roof assembly
2 Bolt

6. Disconnect the bolts and remove the roof assembly.



1
Fig. 8-48
1 Bolt



1
Fig. 8-48
1 Bolt

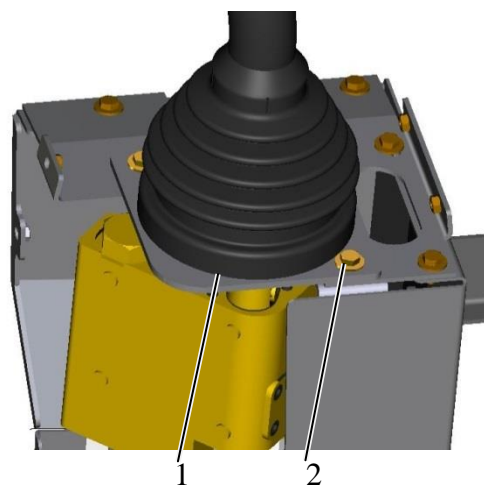

Fig. 8-50
1 Roof assembly 2 Bolt

7. Remove operation box assembly.

835 Assembly of Operation Box

1. Fix the operation box welding assembly on the cab.

2. Install the pilot operating valve, fix the roof assembly with bolts.

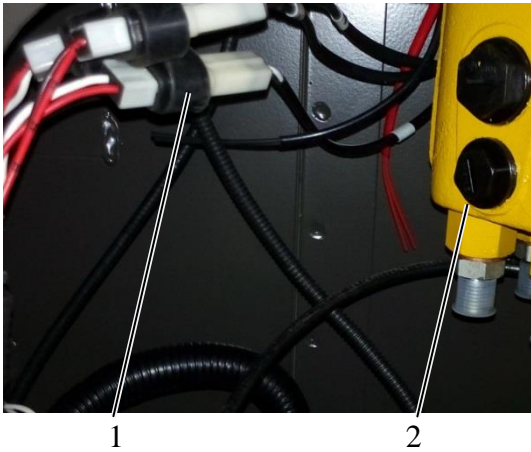

3. Install the relevant wiring harnesses of pilot control mechanism.

Fig. 8-51
1 Wiring harness connector
2 Pilot valve

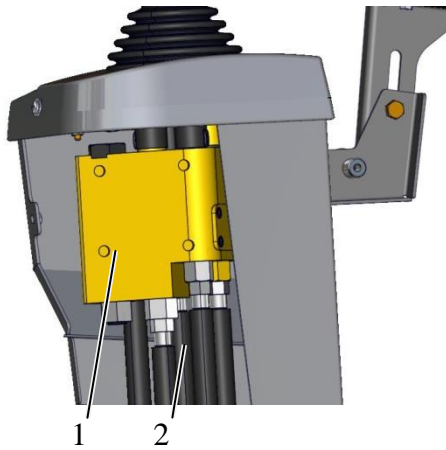

4. Connect the oil pipe and fix it with pipe clamp.

Fig. 8-52
1 Guide valve
2 Hydraulic oil pipe

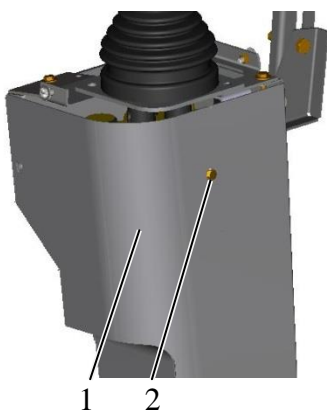

5. Install the operation box periphery shield with bolts.

Fig. 8-53
1 Shield of operation box
2 Bolt



Fig. 8-54

1 Upper cover of operation box

2 Bolt

6. Fasten the upper cover with bolts and gaskets.
7. Assembly of operation box is done.

84 Disassembly and Assembly of Engine Hood

Start the engine and drive the loader to smooth and spacious ground. Wedge the front of the front tires and back of the rear tires with blocks. Keep the bucket flat on the ground, and shut down the engine.



1

Fig. 8-55

1 Wood block



1

Fig. 8-56

1 Window lattice



1

Fig. 8-58

1 Air prefilter

841 Disassembly of Engine Hood

Instrument: 2m lifting rope

1. Move the machine to the maintenance position.
2. Open the window lattice.
3. Disconnect air filter from engine and take it down.

★ ATTENTION

Remove the intake pipe clamp of air filter.



1

Fig 8-58

1 Wiring harness connector

4. Disconnect wiring harness connector of rear lamp and reverse buzzer.

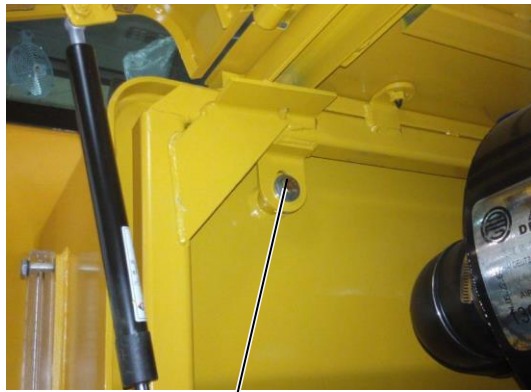

1

Fig. 8-59

1 Bolt

5. Remove the bolts that connecting rear cover and hydraulic oil tank.



1

Fig 8-60

1 Bolt

6. Remove the bolts that connecting rear cover and rear frame.



1

Fig. 8-61
1 Engine hood



1

Fig. 8-62
1 Engine hood



1

Fig. 8-63
1 Bolt

7. Connect one end of the lifting rope to rear cover, the other end to the hoisting appliance. Lift up the rear cover, put in on a cushion carefully.

★ ATTENTION

Keep rear cover stable when putting it down.

842 Assembly of Engine hood

Instrument: 2m lifting rope

1. Connect one end of the lifting rope to the middle of the engine hood armrest, the other end to the lifting appliance. Then lift up the engine hood, and place it on the engine.

★ ATTENTION

Pay attention to the lifting position, avoid the hood falling down. During the lift, it is forbidden to stand under the frame. When putting down the engine hood, don't squeeze your hand.

2. Connect the engine hood and hydraulic oil tank with bolts.

 Nm 90±10Nm



Fig. 8-64
1 Water drain valve

3. Connect engine hood and rear frame with bolts.

 Nm 90±10N•m

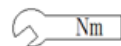
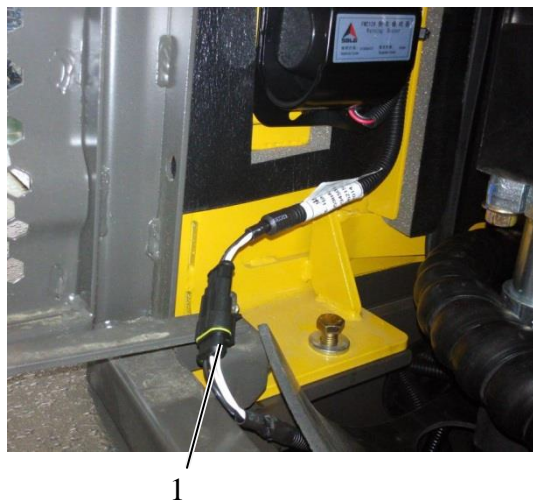

Fig 8-65
1 Bolt

4. Connect the wiring harness connector of rear lamp and reverse buzzer.

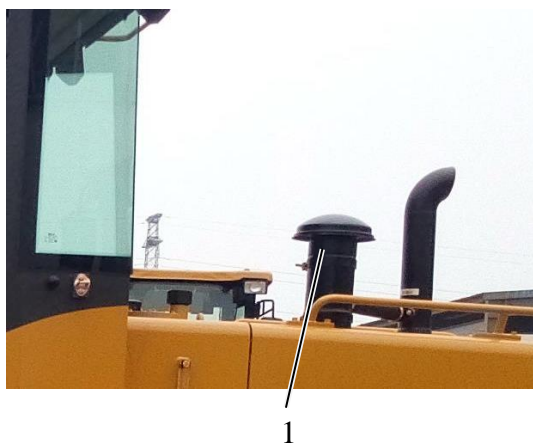

Fig 8-66
1 Air prefilter

5. Install the air prefilter.



1

Fig. 8-67

1 Window lattice

6. Lock the window lattice, assembly of engine hood is finished.

85 Disassembly of Left and Right Platform Assembly



Fig. 8-68
1 Wood block

Start the engine and drive the loader to smooth and spacious ground. Fix the front of the front tires and back of the rear tires with blocks. Keep the bucket flat on the ground, and shut down the engine.

Disassembly of left and right platforms are similar, we take left platform for example.

★ATTENTION

Don't crash the refrigeration pipeline when disassembling and assembling the right platform to avoid the refrigerant leaking.

851 Disassembly of Platform Assembly

Instrument: 2m lifting rope

★ATTENTION

Connect the platform to the lifting rope before disassembling. Avoid the platform falling down after all bolts are removed.



Fig. 8-69
1 Platform 2 Bolt

1. Remove the bolts that connecting the platform and frame.

2. Remove the bolts that connecting platform and hydraulic oil tank.

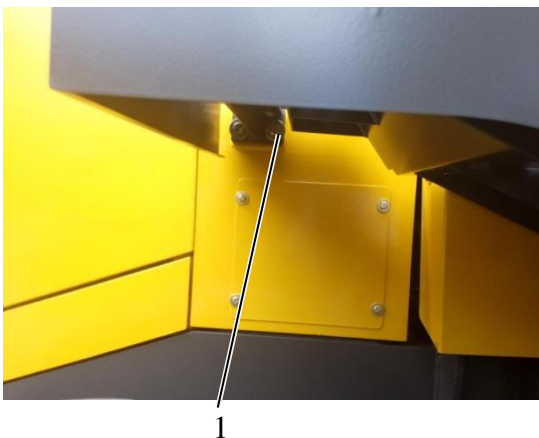

Fig. 8-70
1 Bolt

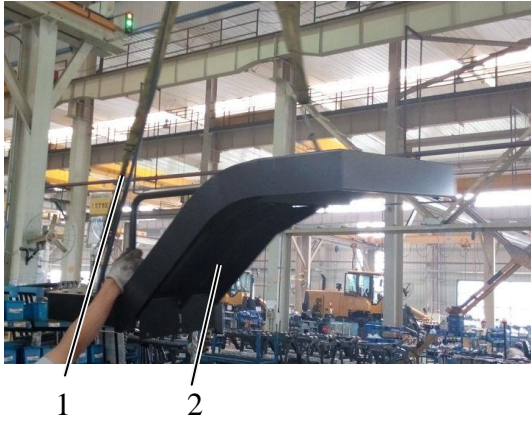

Fig. 8-71

1 Lifting rope 2 Left platform

3. Lift the platform up and put it on the cushion.

852 Assembly of Platform Assembly

Instrument: 2m lifting rope

1. Lift the platform to the proper position and prepare to install bolts.

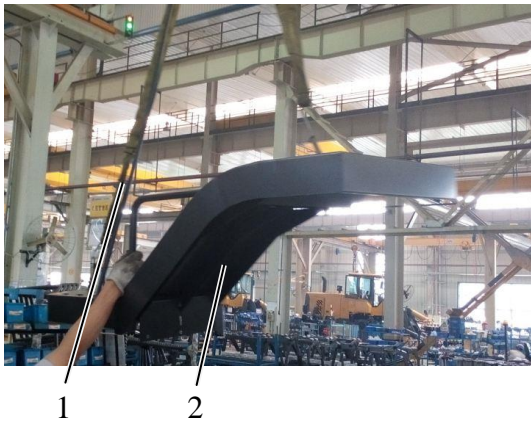

Fig. 8-72

1 Lifting rope 2 Left platform

2. Connect the platform to hydraulic oil tank with bolts.

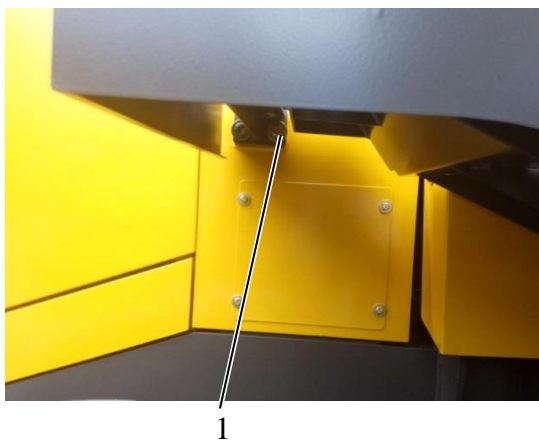

Fig. 8-73

1 Bolt



1

Fig. 8-74
1 Bolt

3. Connect the platform to frame with bolts.
4. Assembly of left platform is done.

86 Disassembly and Assembly of A/C System

861 Disassembly of Evaporator Assembly

1. Drain the refrigerant. Refer to Page 8-45 for details.

★ ATTENTION

Avoid directly contacting the refrigerant.

Do the disassembly in a well-ventilated place.

2. Open the air condition cover.
3. Remove the return air filter, fresh air filter and intake baffle.
4. Disconnect all air-condition related wiring harnesses.

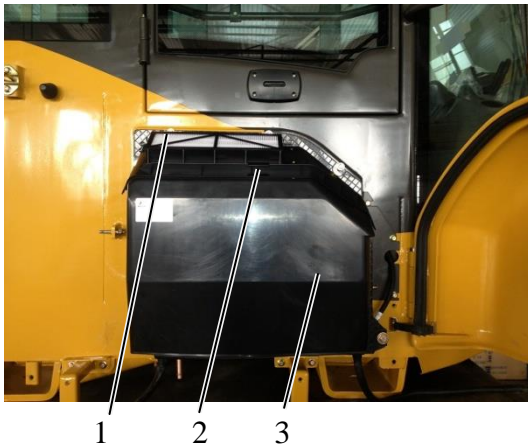

Fig. 8-75

- 1 Fresh air filter 2 Return air filter
3 Intake baffle

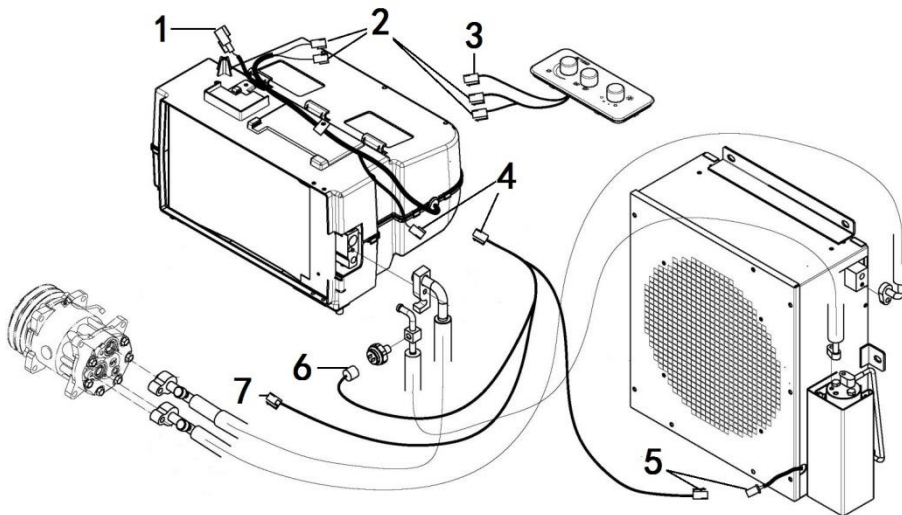

Fig. 8-76

- 1 Power source wiring harness of evaporator assembly
2 Wiring harness that connecting control panel and evaporator
3 Power source wiring harness of air door motor
4 Air condition wiring harness
5 Power source wiring harness of condenser fan
6 Pressure switch wiring harness
7 Power source wiring harness of compressor



1

Fig. 8-77

1 Fan heater water pipe

5. Disconnect the hose clamp connections of engine fan heater pipes on the bottom of cab (right-rear side).



1

Fig. 8-78

1 Bolt

6. Remove the bolts that connecting evaporator and cab.



1 2

Fig. 8-79

1 Bolt

2 Interior trim panel

7. Disconnect the bolts that connecting the right interior trim panel in cab and evaporator assembly.



1

Fig. 8-80
1 Evaporator assembly

8. Take down the evaporator assembly and put it on the proper place.

862 Assembly of Evaporator Assembly



1

Fig. 8-81
1 Evaporator assembly

1. Install evaporator assembly.
2. Connect evaporator air outlet hose and cab intake hose.



1

Fig. 8-82
1 Bolt

3. Fix the evaporator on the cab with bolts.



Fig. 8-83

4. Connect the wiring harnesses of evaporator assembly.



Fig. 8-84

- 1 Bolt 2 Interior trim panel

5. Install the bolts to connect the cab interior trim panel and evaporator assembly.



Fig. 8-85

- 1 Air door motor wiring harness
2 Air door motor

6. Connect the wiring harness between temperature control panel and air door motor.

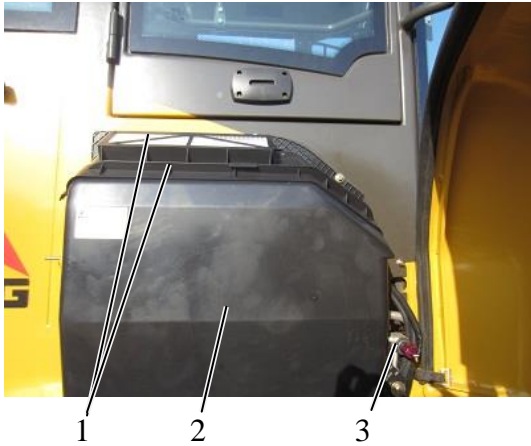

Fig. 8-86

1 Filter 2 Intake baffle
2 Pressure switch

7. Install the air filters and intake baffle, connect pressure switch connector.
8. Close the air condition cover.

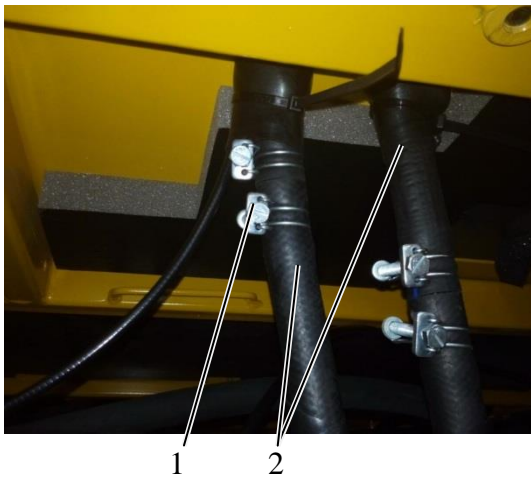

Fig. 8-87

1 Clamp
2 Heater water pipe

9. Connect the engine fan heater water pipes to evaporator and fix them with clamps.



Fig. 8-88

10. Fill refrigerant. For details refer to Page 8-45.
11. Recover the machine and test-run the A/C system.

863 Replacement of Evaporator Components

★ ATTENTION

When a pipeline is disconnected, cover the pipe with plug or multilayer plastic cloth.

1. Remove the evaporator from the machine, and put in on the platform, refer to Page 8-32.



1

Fig. 8-89

1 Evaporator assembly



1

2

Figure 8-90

1 Evaporator

2 Fixed plate

2. Remove the fixed plate on the right side of the evaporator.



1

Figure 8-91

1 Clamp

3. Disassemble all the clamps of the evaporator assembly, and then disassemble the shell.



Figure 8-92
1 Heater core

Replacement of heater core

1. Take down the heater core and replace it.
2. Reinstall the shell, and install all clamps.
3. Reinstall evaporator assembly, refer to Page 8-34.



Figure 8-93
1 Evaporation blower

Replacement of evaporation blower

1. Disconnect the wiring harnesses, take out the blower and install the new one.
2. Reinstall the shell, and install all clamps.
3. Reinstall evaporator assembly, refer to Page 8-34.

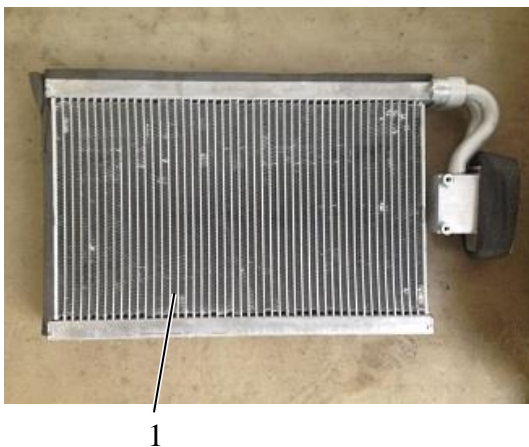

Figure 8-94
1 Refrigerator core

Replacement of expansion valve

★ATTENTION

Drain all refrigerant in the system. Refer to refrigerant draining on Page 8-45.

1. Take out refrigerator core.

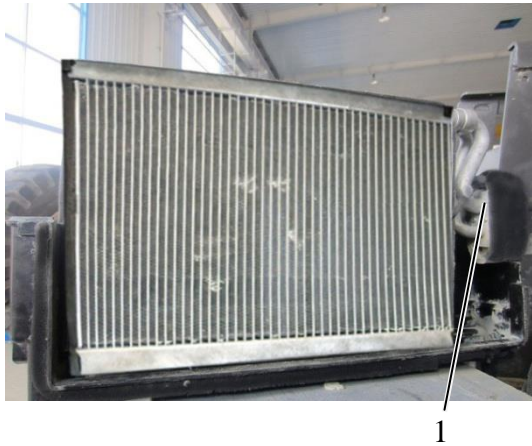

Figure 8-95
1 Expansion valve

2. Disconnect the pipe between expansion valve and refrigerator core, remove the expansion valve.
3. Install the new expansion valve.

★ATTENTION

Keep the interior clean and use refrigerating engine oil to lubricate the seal ring.

4. Connect the expansion valve pipe.

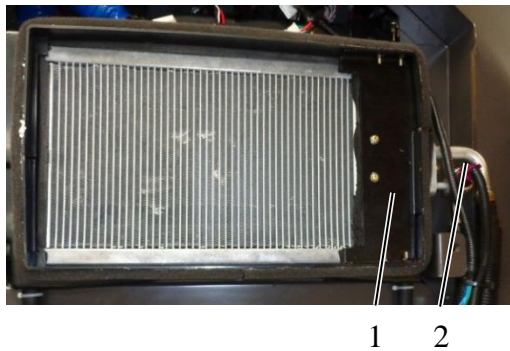

Figure 8-96
1 Fixed plate
2 Pressure switch

5. Install the pressure switch.
6. Install the fixed plate
7. Use vacuum pump to fill system with refrigerant. Refer to filling refrigerant with vacuum pump on Page 8-45.

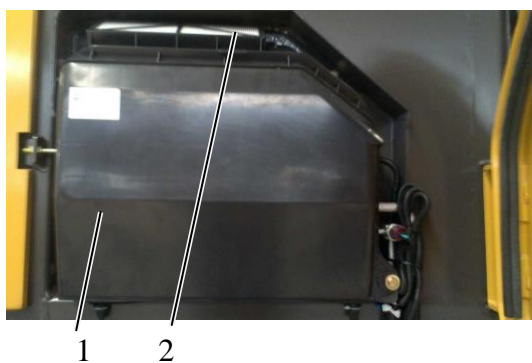

Fig. 8-97
1 Intake baffle 2 Filter

8. Install filters and the intake baffle.
9. Recover the machine and test-run the A/C system.



1

Fig. 8-98

1 Temperature sensor

Replacement of temperature sensor

1. Replace temperature sensor.
2. Install the shell of evaporation assembly and the upper right side fixed plate.
3. Install filters and the intake baffle.
4. Close the air condition cover.
5. Recover the machine and test-run the A/C system.

Replacement of refrigerator core

★ATTENTION

Drain all refrigerant in the system. Refer to refrigerant draining on Page 8-45.

1. Remove the cover clamps, take out refrigerator core and put it aside.
2. Install the new refrigerator core.

★ATTENTION

Keep the interior clean and use refrigerating engine oil to lubricate the seal ring.

3. Install the shell of evaporation assembly
4. Install the evaporator upper right side fixed plate.
5. Install filter cap, filters and air door motor wiring harness.
6. Use vacuum pump to fill system with refrigerant. Refer to filling refrigerant with vacuum pump on Page 8-45.
7. Recover the machine and test-run the A/C system.

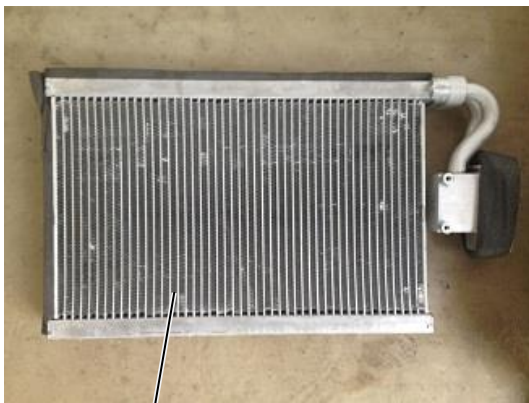

1

Fig 8-99

1 Refrigerator core

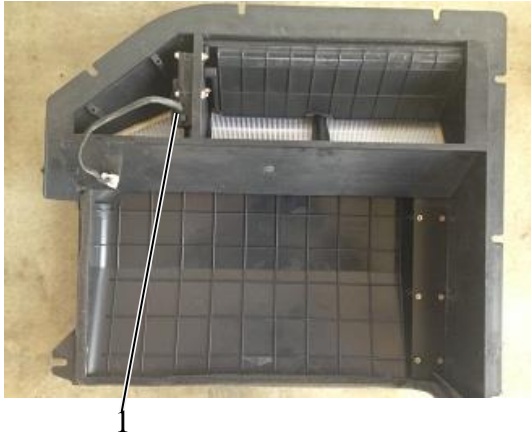

Fig 8-100
1 Air door motor



Fig 8-101
1 Screw



Fig 8-102

Replacement of air door motor

1. Open the shell of evaporator assembly.
2. Remove the filter and filter cap.
3. Disconnect the wiring harness between temperature control panel and air door motor.
4. Put the filter cap on soft cushion to avoid damaging the air mixing door.
5. Remove the fixing screws of air door motor, take down the motor.
6. Install a new motor.
7. Connect the wiring harness between temperature control panel and air door motor.
8. Turn on the battery switch.
9. Test-run and check the functions of air door control panel.
10. Close air condition cover.
11. Recover the machine and test-run the A/C system.

864 Replacement of Condenser Fan

1. Remove the peripheral bolts of condenser cover.

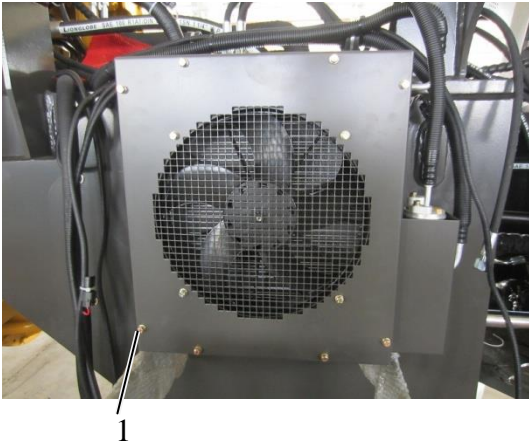

Fig 8-103
1 Bolt

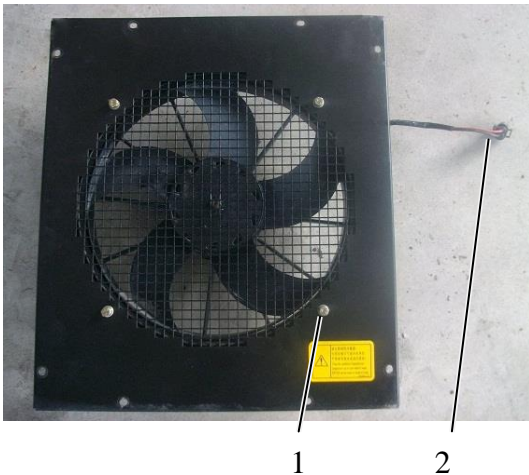

Fig 8-104
1 Condenser fan bolt
2 Fan wiring harness

2. Disconnect the connector of fan motor, remove condenser cover-fan assembly and put it on cushion.
3. Loose the four connecting bolts of condenser fan.



Fig 8-105

4. After replacing with new fan, fasten the four connecting bolts.

★ATTENTION

When assemble new fan, put the fan wiring harness on the upper right position.

5. Assemble condenser cover-fan assembly to the condenser.
6. Recover machine, test-run A/C system.

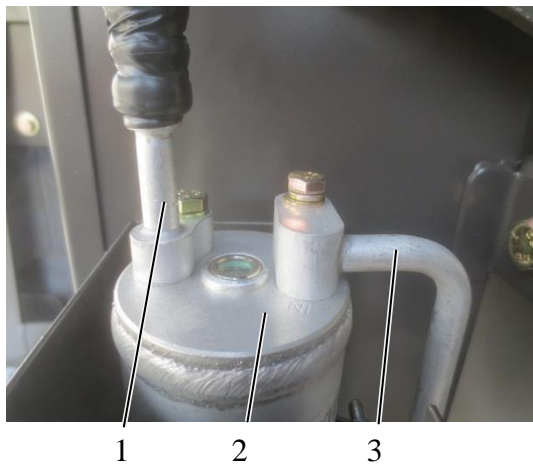
Fig 8-106

- 1 Steam storage pipe
2 Fluid reservoir 3 Condenser pipe

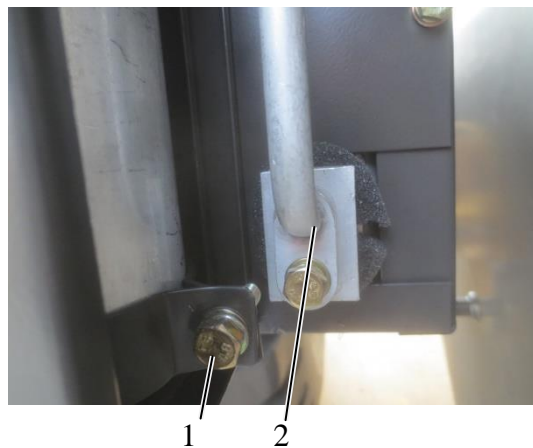
Fig 8-107

- 1 Fixing bolt of liquid storage tank support
2 Condenser pipe

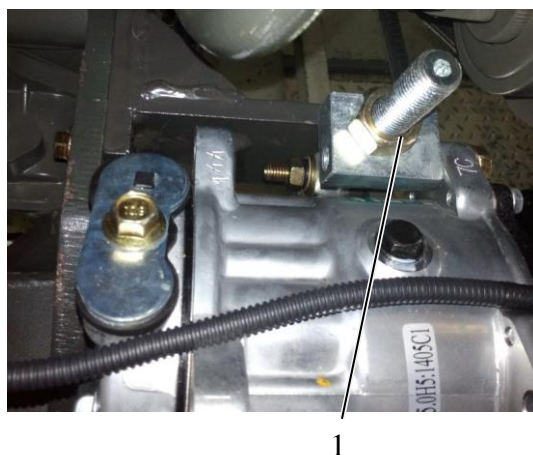
Fig 8-108

- 1 Adjusting screw

865 Replacement of Liquid Reservoir

1. Drain the refrigerant, for details refer to page 8-45.
2. Remove the steam storage pipe that connected with the fluid reservoir. Protecting the steam storage pipe connector well is required.
3. Remove the upper bolts that connecting condenser and fluid reservoir. Protecting the condenser pipe connector well is required.
4. Remove the bottom bolts that connecting condenser and condenser pipe. Protecting the condenser pipe connector well is required.
5. Loose the fixing bolts connecting fluid reservoir support and condenser. Remove the fluid reservoir.
6. Replace with new fluid reservoir and connect it with steam storage pipe and condenser pipe. Before connecting pipes, it is forbidden to remove the plug cap. It can only be opened in the last stage of installation.
7. Install the fluid reservoir fixing bolts.
8. Fill refrigerant, refer to Page 8-45 for details. Recover the machine and check A/C system.

866 Replacement of Compressor Components

★ ATTENTION

When a pipeline is disconnected, cover the pipe with plug or multilayer plastic cloth.

Replacement of compressor belt

1. Put the machine in the maintenance position.
2. Open the engine hood.

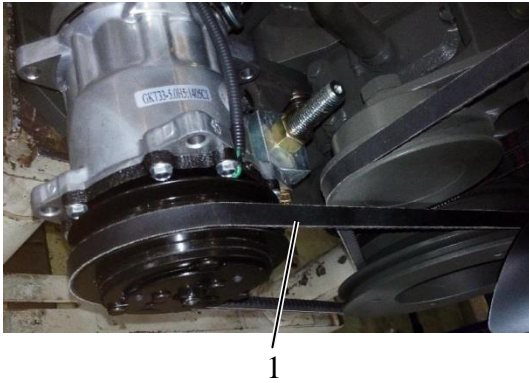

Fig 8-109
1 Belt

3. Loose the connecting bolts and adjusting screw, and then remove the belt.
4. Mount new belt, adjust tensile force, tighten it using connecting bolts and adjust to the proper degree of tightness. When loading 10kg pressure force, it is proper if belt goes down 10~12mm, and then fasten compressor.
5. Recover the machine and test-run the A/C system.

Replacement of compressor

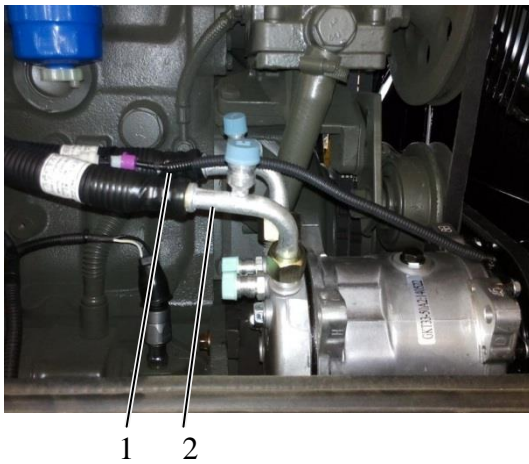

Fig 8-110
1 Compressor to condenser pipe
2 Evaporator to compressor pipe

1. Open the engine hood.
2. Drain all refrigerant in the system, refer to refrigerant draining on page 8-45.
3. Release the tensile force of the belt, remove the belt. Pull out the compressor wiring harness plug.
4. Disconnect compressor to condenser pipe and evaporator to compressor pipe from the compressor. Protecting the condenser connector well is required.
5. Loose and remove the fixing bolts of compressor, then take down the compressor.
6. Install the new compressor with bolts, leave the bolts untightened.
7. Remove the plugs from the refrigerant pipe and compressor. Mount the refrigerant pipe and on the compressor with a new O-ring. Lubricate O-ring with refrigerating engine oil.
8. Install pipe connector, and then mount the clamp of refrigerant pipe.
9. Reinstall compressor belt. Adjust the position of compressor and keep the belt groove of



Fig 8-111
1 Nut



1

Fig 8-112
1 Filling hose

- compressor clutch and that of engine coplanar. Adjust the belt to proper degree of tightness.
10. Refill air condition system. Refer to refrigerant filling and vacuum pump suction on page 8-45.
 11. Recover the machine and test-run A/C system.

867 Draining and Filling of Refrigerant

Refrigerant, Draining

Instruments:

Refrigerant device	Vacuum pump
Adaptor	AC leak detector
Hose	Platform scale



1

Fig 8-113
1 Drain hose

1. Put the refrigerant container on the platform scale. Make sure the volume of the refrigerant container is big enough to contain the refrigerant. Weight the refrigerant, weight of refrigerant = weight of refrigerant and container – weight of refrigerant container. Read the capacity of container from the container.
2. Make sure there is no pressure in the recovery device.
3. Connect the red “draining” hose of the recovery device to the refrigerant container. Connect blue “absorption” hose to low pressure connector of the machine.

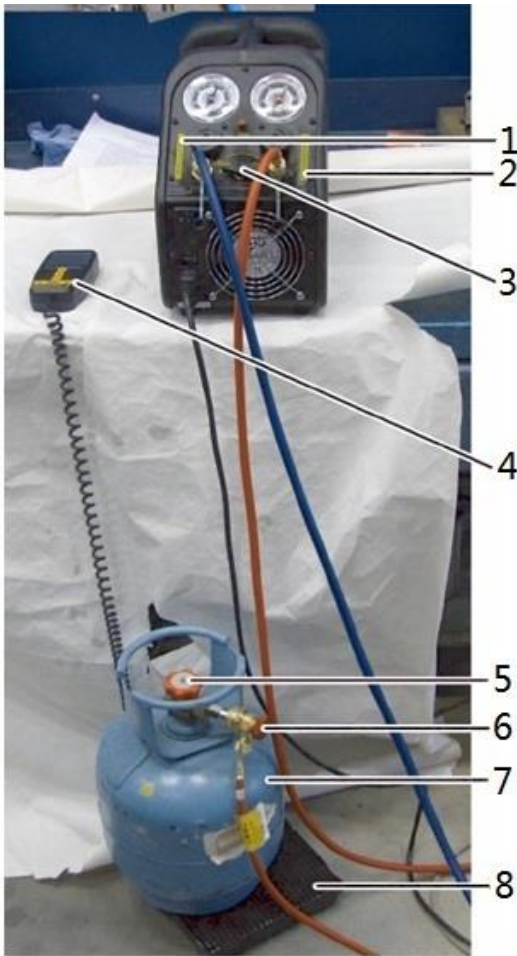

Fig 8-114

- 1 Absorption 2 Draining
- 3 Central controller 4 Scale displayer
- 5 Refrigerant container valve
- 6 Red hose valve
- 7 Refrigerant container
- 8 Platform scale

Drain

4. Open the red hose valve on the refrigerant container.

Open the valve on the refrigerant container.

Open the “draining” valve on the recovery device.

Rotate the central controller to recovery position.

Start the recovery device through the switch, start draining.

Open the blue hose valve through the lower pressure connector of the machine.

Open “absorption” valve

5. When the weight no longer increases, check whether the pressure is lower than the vacuum degree displayed on the pressure gauge.

6. Close the absorption valve.

Close the blue hose valve through the low pressure connector of the machine.

Rotate the central controller to “auto clean”; the blue pressure gauge falls to vacuum degree again.

Close the recovery device.

Close refrigerant container valve.

Close draining valve.

7. Disconnect the recovery device from the machine.

Refrigerant filling, including vacuum pumping

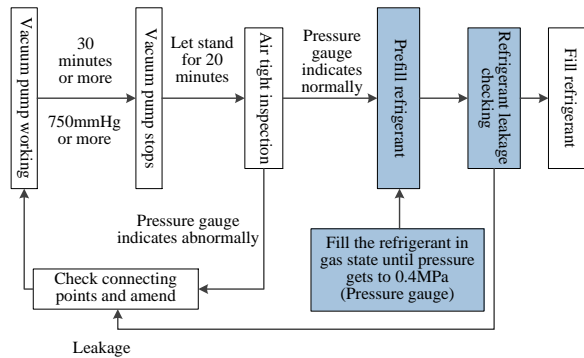

Fig 8-115

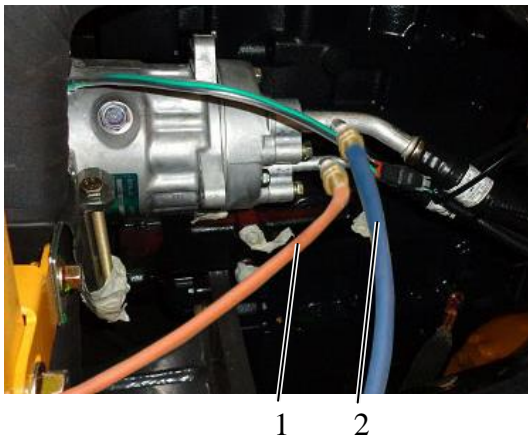

Fig 8-116

1 Red hose

2 Blue hose

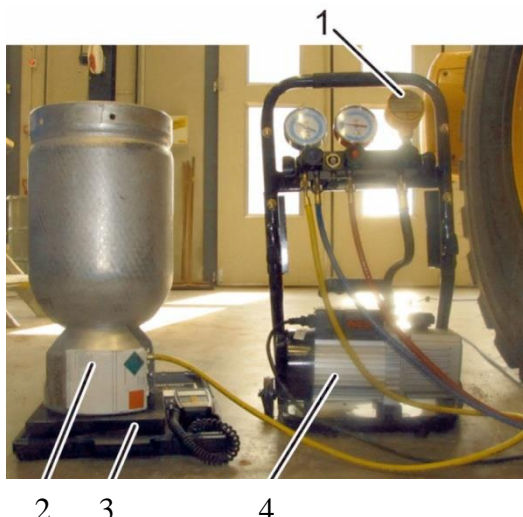

Fig 8-117

1 Vacuum gauge

2 Refrigerant container

3 Platform Scale

4 Vacuum pump

Vacuum exhaust

1. Close all of the valves on the pressure gauge box.
2. Connect the red hose to the high pressure connector on the machine.

Open the hose valve through the machine connector.

3. Connect the blue hose to the low pressure connector on the machine.

Open the hose valve through the machine connector.

4. Connect the yellow hose to the refrigerant container.

Place the refrigerant container upside down on the platform scale.

Check whether there is refrigerant in the container. Weight of refrigerant = weight of refrigerant and container – weight of refrigerant container.

5. Open the two green valves on the pressure gauge box.

Start the vacuum pump.

6. Open the blue and red valves on the pressure gauge box.

Start the vacuum gauge.

7. Keep the vacuum pump working at least for 50 minutes.

8. When reached the right pressure, close the two green valves, red valve and blue one on the pressure gauge box.

Close the vacuum pump.

Disconnect the hoses from the machine.

Filling

9. Connect the adaptor to the low pressure connector of the machine, and fill in the same volume of oil consumed by system.

Remove the adaptor.

10. Connect the red hose to the high pressure connector of the machine.

Connect the blue hose to the low pressure connector of the machine.

11. Press the TARA (reset the scale) on the scale displayer.

Open the yellow valve on the pressure gauge box.

12. Open the blue valve, start filling.

13. Under the condition of opening AC power, start the engine. Run the engine at the speed of 1000rpm.

14. When the platform scale shows the right weight of the refrigerant, close the refrigerant valve (refer to the information on the inside of the machine hatch).

Close the yellow valve on the pressure gauge box.

15. Close the hose valve through the machine connector.

Close all of the valves on the pressure gauge box.

16. Open the red and blue valves through the machine connectors and check the pressure at the speed of 1800rpm.

17. Disconnect the red and blue hoses from the machine.

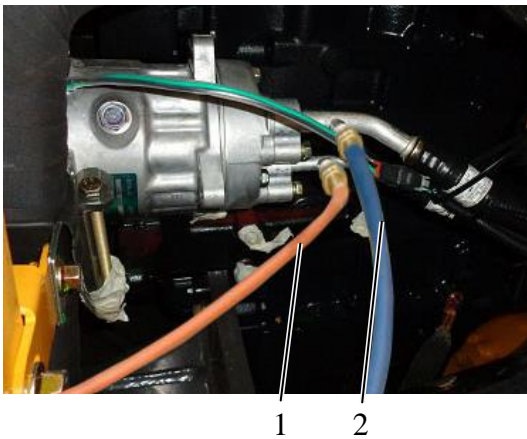

Fig 8-118

1 Red hose

2 Blue hose

87 Diagnosis and Solutions for Common Faults of A/C System

When check and maintain the failures of the air condition system, you must check the reasons according to the abnormal phenomena, and then take measures. The common failures of A/C system are non-refrigeration, non-heating, insufficient refrigerating capacity and so on.

871 Regular Checking Items

The A/C system of the loader is working in bad environment. So it may be damaged whether it is working or not. The usual maintenance must be strengthened.

Check the pipeline connectors, compressor support, Degree of tightness of the compressor belts regularly. Check whether the hoses of the A/C system have wear phenomena, check wiring harnesses and keep the surface of the condenser clean.

Table 8-1 Regular checking item list

Checking items	Checking details	Checking interval		
		Daily	Semiannually	Annually
Pipeline assembly	Bad fixation, with gaps.	<input type="checkbox"/>	▲	▲
	Connection loose, nuts and bolts loose.	▲	▲	<input type="checkbox"/>
Connecting bolts	Connection loose, nuts and bolts loose and falling off.	<input type="checkbox"/>	▲	▲
belt	Loose and bend.	▲	<input type="checkbox"/>	▲
	Degraded, worn, scar, cracked.	<input type="checkbox"/>	▲	▲
	Noise, abnormal odor and heat.	<input type="checkbox"/>	<input type="checkbox"/>	▲
Condenser assembly	Radiator fin lodging	<input type="checkbox"/>	<input type="checkbox"/>	▲
	Foreign matter block	▲	▲	▲
Ari condition air flow switch	Startup check, air volume and switch control.	▲	<input type="checkbox"/>	▲
	Switch function	▲	<input type="checkbox"/>	▲
Refrigerant leakage	Pipe joint leakage	▲	▲	<input type="checkbox"/>
	Internal leakage in the components	<input type="checkbox"/>	<input type="checkbox"/>	▲
Refrigerant volume	Check the volume of refrigerant	▲	<input type="checkbox"/>	▲
Noise	Compressor	<input type="checkbox"/>	▲	<input type="checkbox"/>
	Condenser fan, evaporator fan	<input type="checkbox"/>	▲	<input type="checkbox"/>
Receiver-drier temperature difference	Existing of temperature difference means there is foreign matter blockage	<input type="checkbox"/>	<input type="checkbox"/>	▲

872 Non-Refrigeration Fault Analysis

Table 8-2 Non-refrigeration fault analysis list

Non-refrigerant	Evaporator fan rotates	Condenser fan doesn't rotate	Compressor doesn't work	Checking items: fan connector, ground connection and fan.
			Compressor works	Checking items: temperature control switch, relay and relay connector.
		Condenser fan rotates	Compressor doesn't work	Checking item: clutch, connector and belt
	Evaporator fan doesn't rotate	Condenser rotates, compressor works	Check whether speed-control switch is failure, whether fan wire is disconnected, whether ground connection wire of fan is good.	
		Condenser doesn't rotate, compressor doesn't work	Check whether fuse is burned, whether relay is normal, whether connection wire is loose.	
	Compressor is normal	Fans of evaporator and condenser work normally	If not used for long time, the R134a in the system might leak. Use high-low pressure gauge to check whether there is R134a or not.	

873 Insufficient Refrigerating Fault Analysis

Table 8-3 Insufficient refrigerating fault analysis list

Insufficient refrigerating	Compressor works normally	Fans of evaporator and condenser works normally, so as the evaporator and condenser	Import and export of fluid reservoir are connected reversely。
			Check whether the expansion valve is blocked by ice or contaminant, replace the fluid reservoir.
			Replace R134a
		Fan works normally, so as others.	Check whether there is foreign matter blocked on the condenser surface.

874 Non-Heating Fault Analysis

Table 8-4 Non-heating fault analysis list

Non-heating	Evaporator works normally	Check whether electromagnetic valve works normally, whether there are other valves of heating pipeline not opened.
	Evaporator doesn't work	Check whether speed-control switch is in failure, whether fan wire is disconnected, whether grounding wire of fan is good. Check whether fuse is burned, whether connecting wire is loose.

875 Other Fault Analysis

Table 8-5 Other fault analysis list

No.	Phenomena	Causes	Solutions
1	At the beginning, the refrigeration performance is good. After a period of time, refrigerating capacity is not enough; observing through observation hole of reservoir, bubbles appear; both readings of high and low pressure gauge are low.	The loader was traveled on the rough ground frequently. Connectors become loose because of vibration and leakage appears.	Use leak detector to find the leaking position and tighten the leak parts carefully.
2	System doesn't refrigerate, the airport blows hot air. There is no hand-feeling temperature difference of the import and export of the expansion valve.	Misused the loader, temperature warp of expansion valve is worn and leak. The valve hole is blocked.	Replace expansion valve and refill R134a
3	Air volume of outlet isn't cool, compressor temperature rises. Pointer of low pressure gauge decline to near zero quickly. Reading of high pressure gauge is higher than normal range.	There are impurities in the system, filter screen of expansion valve is blocked. Thin frost of sweat appears on expansion valve.	Start refrigerating system intermittently, when the block is not serious, this method can eliminate the instantaneous blockage. Or remove the expansion valve and clean it with alcohol. Empty the system and refill R134a.

4	Refrigerating capacity is not enough, evaporator frosts; readings of high and low pressure gauges are lower than normal level.	Flow restriction orifice of expansion valve doesn't work.	Empty the system, replace expansion valve and refill R134a.
5	After running for a period, refrigerating capacity declines, high pressure gauge is higher than normal level and low pressure gauge is lower than 0.4Mpa.	Desiccant of receiver-drier is saturated. Flow restriction orifice of expansion valve is blocked by ice.	Empty the system, replace fluid reservoir and refill R134a.
6	Start refrigerating system, there is air flow but is not cool. Readings of high and low pressure gauge don't change.	Temperature control switch has a bad contact or electromagnetic clutch coil of compressor is damaged.	Use multi-meter to check whether temperature control switch is damaged; replace electromagnetic clutch of compressor.
7	Action of electromagnetic clutch of compressor is too frequent, contact time is short. Cab is not cool but readings of high and low pressure gauge is normal.	Opening degree of temperature control switch is too small which force the compressor stop automatically and cause refrigerating capacity is not enough.	Check temperature control switch and turn it to the coldest position.

★ Notes when overhauling refrigerating system:

- 1. When checking, wear protective glasses or mask as far as possible. Avoid contacting refrigerant directly which can frostbite body. Once contacting with large number of refrigerant, rinse the contact part with cold water.**
- 2. Maintain the refrigerating system in well-ventilated place. As the refrigerant is colorless and odorless, it can make people suffocate because of lack of oxygen.**
- 3. Refrigerant will produce toxic phosgene when meeting flame. Avoid exposing the refrigerant to fire.**
- 4. In order to avoid the risk of explosion, do not weld or rinse with hot steam near the air condition pipeline or components.**
- 5. When replacing the components, keep the connector and inner chamber of system clean. Follow the criterions as shown in Table 8-6 to replenish refrigerating engine oil.**

Table 8-6 Volume of refrigerating engine oil

Component name	Replenish volume/mL
Evaporator	40~50
Condenser	40~50
System connecting hose	30~40
Fluid reservoir	15~25

6. After replaced air condition components, connect the pipeline joints. Tighten them in accordance with required tightening torque as shown in Table 8-7.

Table 8-7 Tightening torque

Thread specification	M5	M6	M8	M10
Tightening torque (Nm)	6~8	10~12	12~15	20~25



Service Manual

LG936L



9 Working Hydraulics

CONTENTS

9 Working Hydraulic System	9-1
91 Components, Locations	9-1
92 Description of System Principle.....	9-2
93 Description, Disassembly and Assembly of Hydraulic System Components ...	9-5
931 Working Pilot Pump	9-8
932 Hydraulic Oil Tank.....	9-15
933 Multitandem Valve	9-20
934 Pilot Operating Valve	9-34
935 Hydraulic Cylinders.....	9-35
936 Pressure Selection Valve	9-45
94 Pressure Measuring Methods and Standards of Working Hydraulic System ...	9-46
95 Diagnosis and Solutions for Common Faults of Hydraulic System	9-48

9 Working Hydraulic System

91 Components, Locations

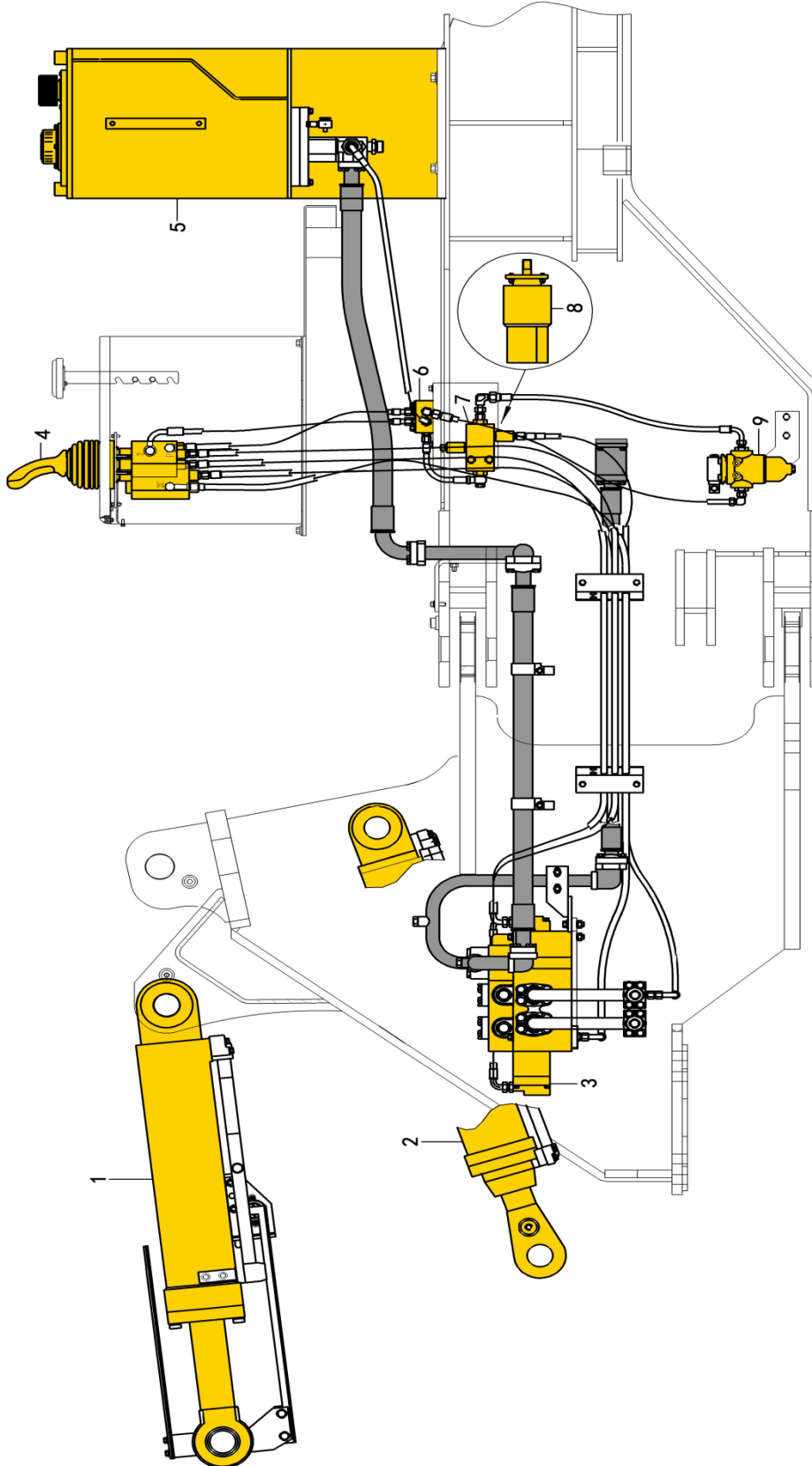

Fig. 9-1 Components, Locations

- 1 Bucket cylinder
- 2 Boom cylinder
- 3 Mutitandem valve
- 4 Pilot valve
- 5 Hydraulic oil tank
- 6 Oil return block
- 7 Pressure selection valve
- 8 Working pump
- 9 Filter

92 Description of System Principle

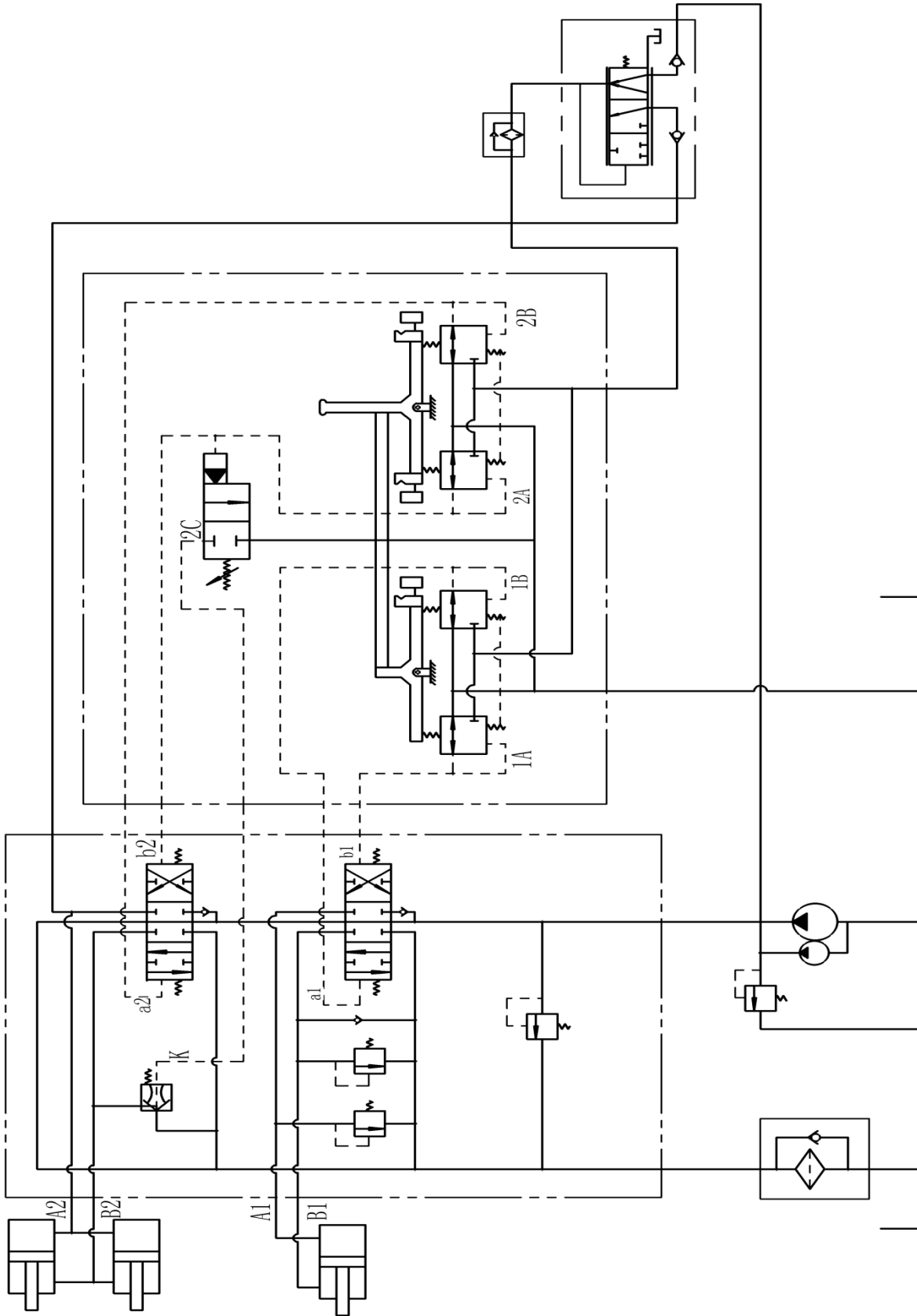

Fig. 9-2 Hydraulic system principle diagram

Working device hydraulic system is composed of multitandem valve, pilot valve, pressure selection valve, boom cylinders, bucket cylinder, hydraulic oil tank and pipeline accessories.

The multitandem valve is a triple valve, one part for bucket, one for boom and the third one is a reserved slide valve for further hydraulic functions.

Median function of multitandem valve

When set the pilot handle in neutral position, no control oil flows into multitandem valve. The valve keeps in neutral position under spring force. At this point, the pumped oil flows back to hydraulic oil tank through multitandem valve directly.

General functions

When operate the pilot handle to carry out forward tilt, backward tilt of bucket or lift, falling of boom, the corresponding control port of corresponding slide valve on main control valve will receive the control oil sent by pilot valve. The control oil pushes slide valve to allow high pressure oil from working pump flowing into the corresponding cylinder to get the action we need.

The move of slide valve is proportional to control oil pressure; its displacement is determined by control oil pressure and the built-in spring.

Boom floating function

When pilot handle is in limiting position of “boom lowering”, on the one hand, pilot valve sends a control pressure to boom part of the multitandem valve to keep the boom part stay in “boom lowering” position; on the other hand, the pilot valve makes the logical valve in boom rod-side chamber connect to hydraulic tank, at this point, the logical valve is open. The rod-side chamber of boom is connected to oil return line, and zero-pressure idle loop is formed in the system. The boom cylinder works in floating state under its own gravity and the enclosed oil pressure.

Auto reset function

Automatic reset system is composed of two parts, boom limit control system and bucket flat control system. When the boom is lifted to limiting position or the bucket is turned to horizontal position, the boom or bucket proximity switch will send electrical signal to deenergize the coil of pilot valve, and the multitandem valve goes back to neutral position, so the boom can stay in limiting position or the bucket can stay horizontal.



1

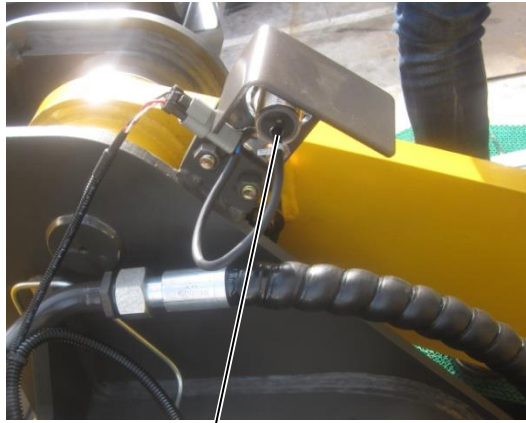

2

Fig. 9-3 Proximity switch

1 Bucket proximity switch

2 Boom proximity switch

93 Description, Disassembly and Assembly of Hydraulic System Components

★ Service precautions for working hydraulic system

The most common fault for high-pressure and high-precision hydraulic devices is that fouling (alien material) occurs in the hydraulic circuit. Thus, pay special attention to the cleanliness when adding hydraulic oil or removing and refitting the hydraulic devices.

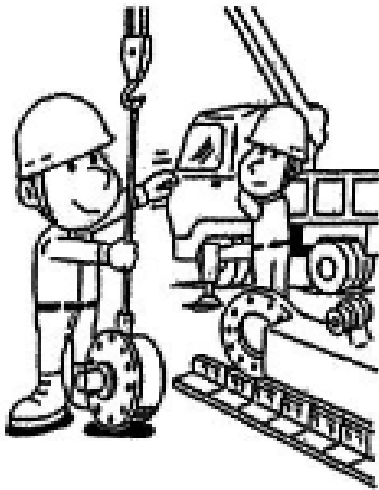

Fig. 9-4

1. Pay attention to working environment.

Avoid adding hydraulic oil, replacing filter or repairing machine in rain or at windy and dirty place.

2. Removing and servicing machine on outdoor site.

Chances are that fouling will enter the equipment if removal and service are done on outdoor site; moreover, it is difficult to appraise equipment's performance after eliminating the faults. So this is only suitable for replacing components. Removal and service of the hydraulic devices should be conducted in special dust-free workshop and the performance of the hydraulic devices should be appraised with special testing device.

3. Seal up the openings.

After removing the pipes or components, all openings should be sealed with cap, adhesive paper or plastic bag so as to prevent fouling or dirt from entering them. If you let the openings be exposed or clogged with rags, fouling is liable to get into them or the leaking oil will stain the surrounding places, which is not allowed to happen. Instead of draining oil to the ground, you should collect the drained oil



Fig. 9-5

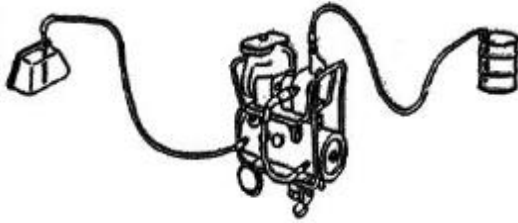

Fig. 9-6

and take it back to handle it on your own.

4. Prevent any fouling or dirt from entering the system during the oil refilling operation.

Prevent any fouling or dirt from being mixed into the hydraulic oil when refilling hydraulic oil and be sure to keep the oil filler and the surrounding surface clean as well as use clean oil pump and container. Utilizing oil cleaning device will filter the fouling deposited during the storage period from the oil, which is more effective for refilling oil.

5. The hydraulic oil should be changed when the oil temperature is high.

When the hydraulic oil or other oil is hot, their fluidity is good and the deposited sludge is easy to be flushed away by the oil. Therefore, it is recommended to change oil when the oil is hot. Discharge the old oil fully (not only the oil in the hydraulic oil tank but also the oil in the filter and plugs of the pipeline) as possible as you can when changing oil. If there is old oil residual, the fouling and deposited sludge will be mixed with the new oil, shortening the service life of the new oil.

6. Flushing operation

The fouling, oil sludge and old oil in the hydraulic oil circuit should be flushed away with rinsing oil when changing oil after the disassembly and assembly of the hydraulic devices. Normally, flushing is conducted for two times: primary flushing with rinsing oil and secondary flushing with specified hydraulic oil.

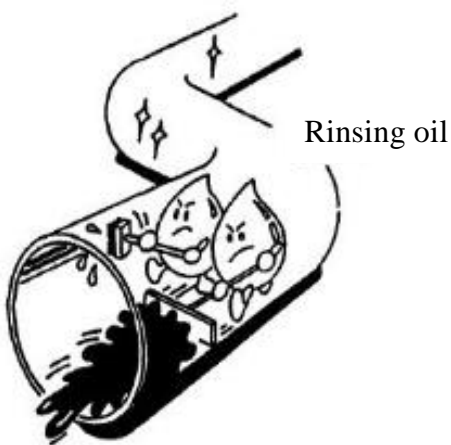

Fig. 9-7

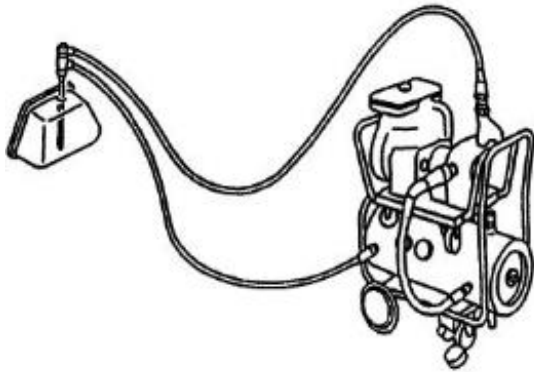

Fig. 9-8

7. Cleaning operation

Get rid of the sludge and fouling in the hydraulic oil circuit with oil cleaning device after repairing the hydraulic device (pump, control valve, etc.) or when the machine is operating. The oil cleaning device is used to remove the ultrafine granule that cannot be removed by the filter in the hydraulic device, which is a very effective cleaning tool.

8. Torque requirements

The securing operation should be conducted in strict accordance with the torque required in this manual during the process of removal, refitting and service of the hydraulic system. Excessive or insufficient torque will lead to hydraulic oil leakage.

★ ATTENTION

For the torque that is not indicated, please refer to relevant requirements in *Chapter 0 General of this manual*.

9. Bleeding of working hydraulic system

After replacement of hydraulic pump, hydraulic cylinder, hydraulic pipe, joint and all kinds of valves, bleeding operation must be done.

The specific bleeding steps are as follows:

- 1) Open the filler cap of hydraulic tank.
- 2) Start the engine; run the engine at idle for 5 minutes, and then retract and extend all cylinders from bottom for about 2~3 times, keep the stroke within 50~60 mm.
- 3) Keep the engine run at low speed, and then retract and extend all cylinders fully for about 3~5 times to bleed the air in hydraulic circuit.
- 4) After the bleeding, set the machine and working device in standard position, check hydraulic oil level and tighten the filler cap.
- 5) Shut down the engine, check for leakage.

931 Working Pilot Pump

Working pilot pump is double gear pump. It is composed of front pump cover, rotating seal shaft, seal ring, O-shape seal ring, side plate, pump body, bearing, rear pump cover, driving gear and driven gear.

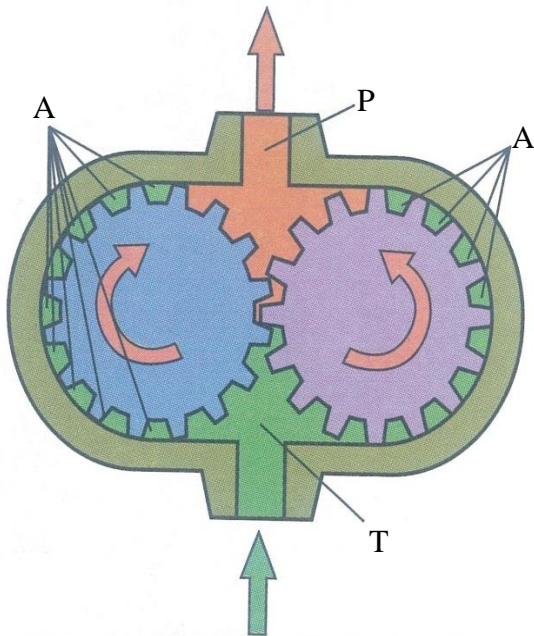

Fig. 9-9 Working principle

Working principle

When pump shaft rotates as Fig. 9-9, the gear demeshes on oil absorption chamber side, oil absorption chamber close volume (T) increases and partial vacuum will be formed, oil in the tank will be pressurized into absorption chamber through the oil absorption pipe under the force of atmospheric pressure to fill up the inter-tooth space. As the gear rotates, oil in transition area A will be brought into oil extrusion chamber P, the gear meshes on the extrusion side and the volume decreases to force oil into oil circuit.

Diagnosis and solutions for common faults

Table 9-1

No.	Fault phenomenon	Cause	Elimination method
1	Oil in hydraulic tank reduces, while oil in transmission box increases.	Damaged oil seal.	Measure the pressure and replace oil seal ring or working pump.
2	Oil in hydraulic tank increases, while oil in transmission box reduces.	Damaged oil seal.	Measure the pressure and replace oil seal ring or working pump.
3	Oil leakage of pump body junction surface.	Damaged O-ring or loose bolt.	Replace the O-ring or fasten the bolt.
4	Oil leakage of pump body	Bump body crack.	Check and replace the working pump.
5	Abnormal sound produced by steering pump.	Excessive wear of spline shaft.	Replace the spline shaft or working pump.
		Excessive wear of side plate.	Replace the side plate or working pump.
		Out of tolerance of spine shaft.	Replace the spline shaft or working pump.
		Bearing failure.	Replace the bearing or working pump.
6	Insufficient output flow result in slow motion.	Excessive wear of side plate or gear.	Replace the relevant parts or working pump.

Disassembly of the Working Pump
★ ATTENTION

Before dismantling the hydraulic oil tank, be sure to carefully read *service precautions for working hydraulic system* previously exposed in this chapter.



Fig. 9-10

1. Drain oil.

Start the machine and drive it to the flat spacious place. Raise the boom to the highest position. Tilt the bucket backward, and then shut down the engine.

Push the control handle of the pilot valve towards right slowly. Let the bucket tilt forward gently to drain the oil in bucket cylinder.

After the bucket reaches its extreme position, push the handle forward gently. Let the boom fall slowly to drain the oil in boom cylinder. Keep the bucket flat on ground. Then operate the handle left and right, back and forth for 5~6 times to drain the internal oil pressure of the system.

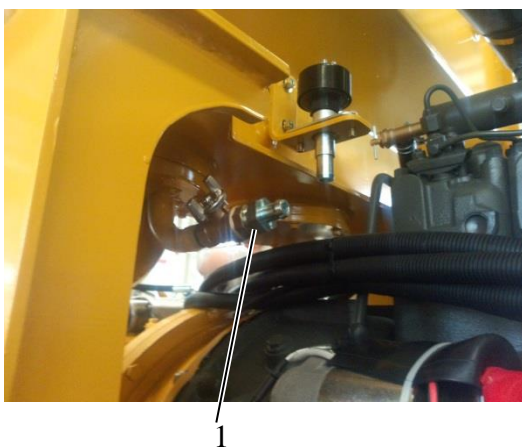

Fig. 9-11

1. Oil drain valve

2. Fix the loader tires with wood blocks stably.

3. Connect a hose to the oil draining valve on the bottom of hydraulic tank, and put the other end in a clean vessel. Open the draining valve of the tank to drain the hydraulic oil out. (Open the filling cap of the tank to accelerate the draining speed)

★ ATTENTION

Cover the drained oil to prevent contamination.

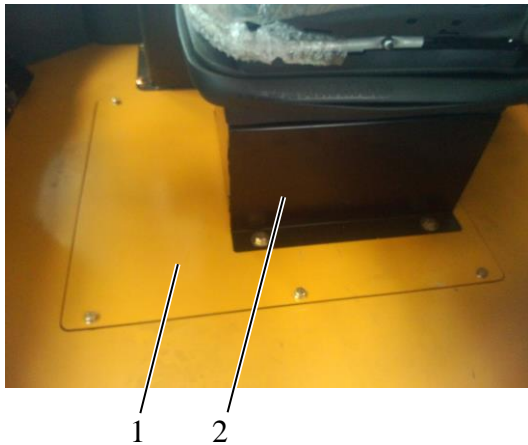

Fig. 9-12
 1 Maintenance cover plate
 2 Seat

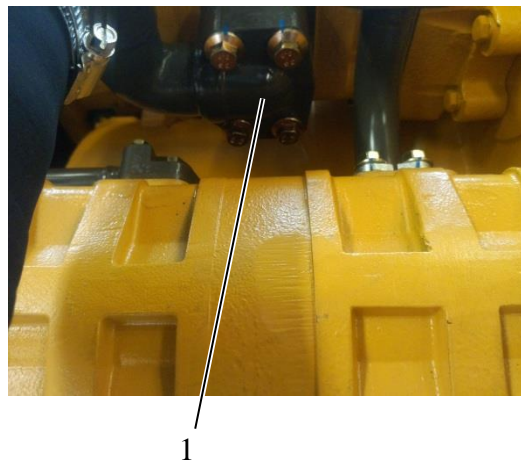

Fig. 9-13
 1 Working pump oil absorption steel pipe

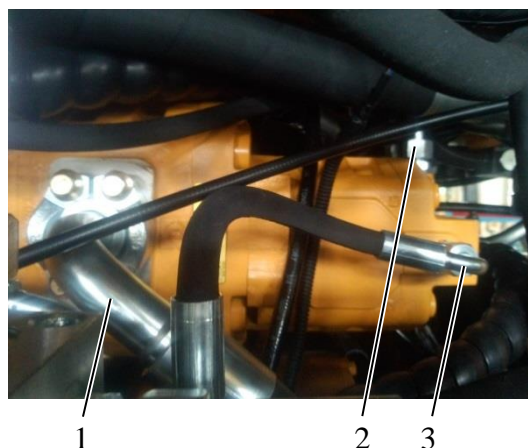

Fig. 9-14
 1 Working pump oil outlet steel pipe
 2 Pilot pump oil return rubber hose
 3 Pilot pump oil outlet rubber hose

4. Remove the fixing bolts of seat, and then lift it away.
5. Remove the fixing bolts of maintenance cover plate in the cab, and then take down the plate.
6. Loosen the bolts that used to fix working pump oil absorption steel pipe on pump oil inlet port, and then remove the pipe.
7. Disconnect the oil outlet rubber hose and oil return rubber hose of pilot pump.
8. Remove the fixing bolts between working pump oil outlet steel pipe and working pump connecting flange; take town the bolts, fission flange and O-ring.

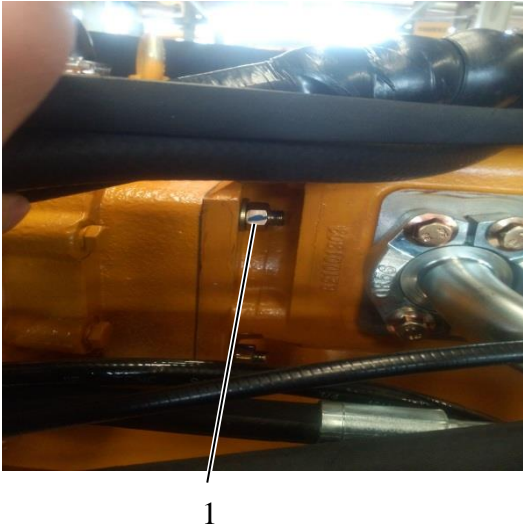

Fig. 9-15
1 Nut

9. Loosen the connecting bolts between working pump and speed changer-torque converter assembly, remove the nuts and gaskets; and then take down the working pump and sealing gasket.
10. Remove the two pipe joints of pilot pump.

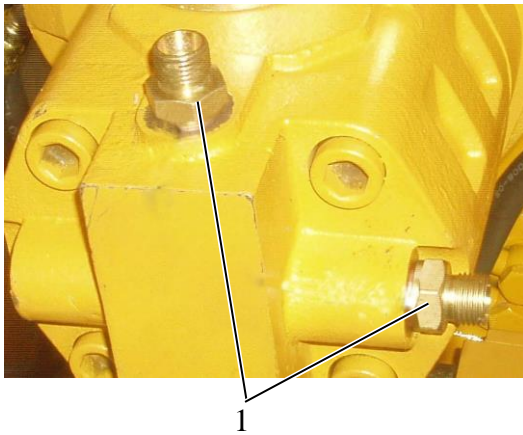

Fig. 9-16
1 Straight joint

- Assembly of the working pump**
1. Install the straight joints to the overflow port and oil outlet port of double pump with gaskets.

 $45 \pm 5 \text{ Nm}$

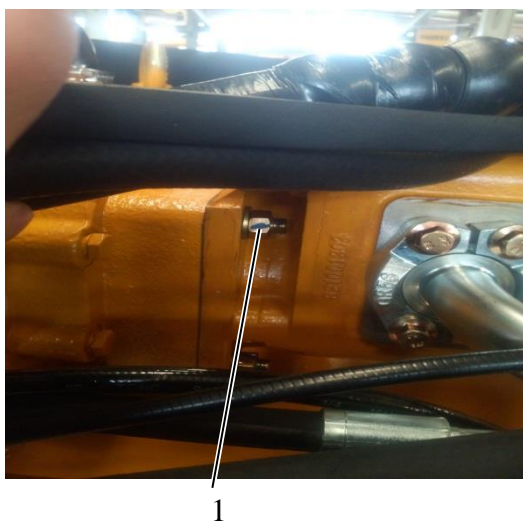



Fig. 9-17
1 Nut

2. Connect the working pump to auxiliary power take-off port of transmission box with four M12 nuts and gaskets and sealing gasket.

 $75 \pm 5 \text{ Nm}$

★ ATTENTION

Tighten the studs first.

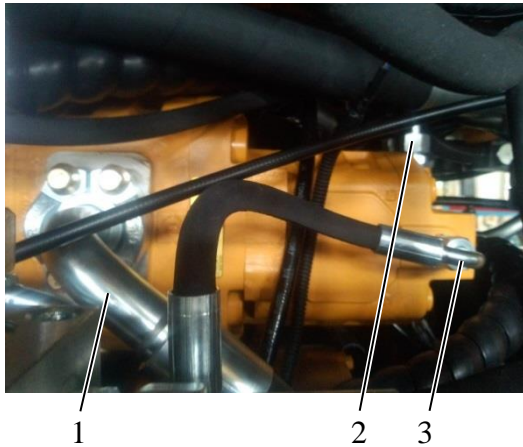

Fig. 9-18

- 1 Working pump oil outlet steel pipe
- 2 Pilot pump oil return rubber hose
- 3 Pilot pump oil outlet rubber hose

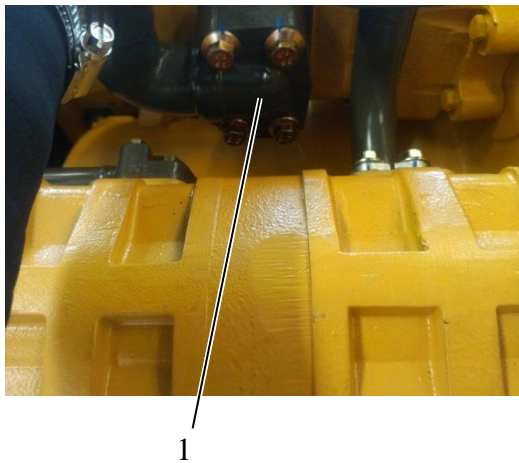

Fig. 9-19

- 1 Working pump oil absorption steel pipe

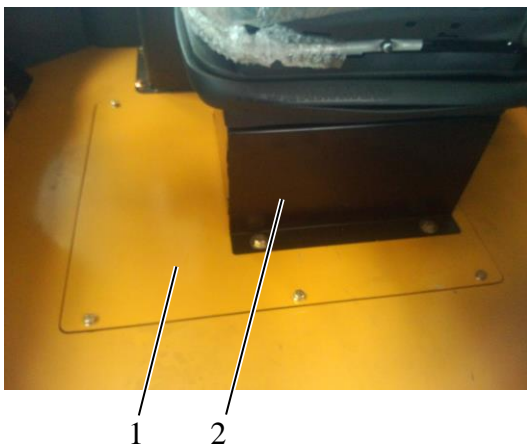

Fig. 9-20

- 1 Maintenance cover plate
- 2 Seat

3. Fasten the pilot pump oil outlet and oil return rubber hoses to the corresponding joint respectively.

 Nm 35±5 Nm

4. Install the working pump oil outlet steel pipe to the corresponding port with bolts and fission flange.

 Nm 45~59Nm

5. Put an O-ring in O-ring groove of working pump oil absorption steel pipe joint, and then assemble it to the steering pump oil outlet port with four bolts and fission flange.

 Nm 78~104Nm

6. Install the maintenance cover plate assembly on the platform in cab with bolts.
7. Reset the seat and fix it with bolts.



Fig. 9-21
1 Oil filling port

8. Fill the hydraulic oil to the required level.

932 Hydraulic Oil Tank

It is used to provide oil to the whole hydraulic system. An oil return filter is designed in the tank to ensure the cleanliness of hydraulic oil.

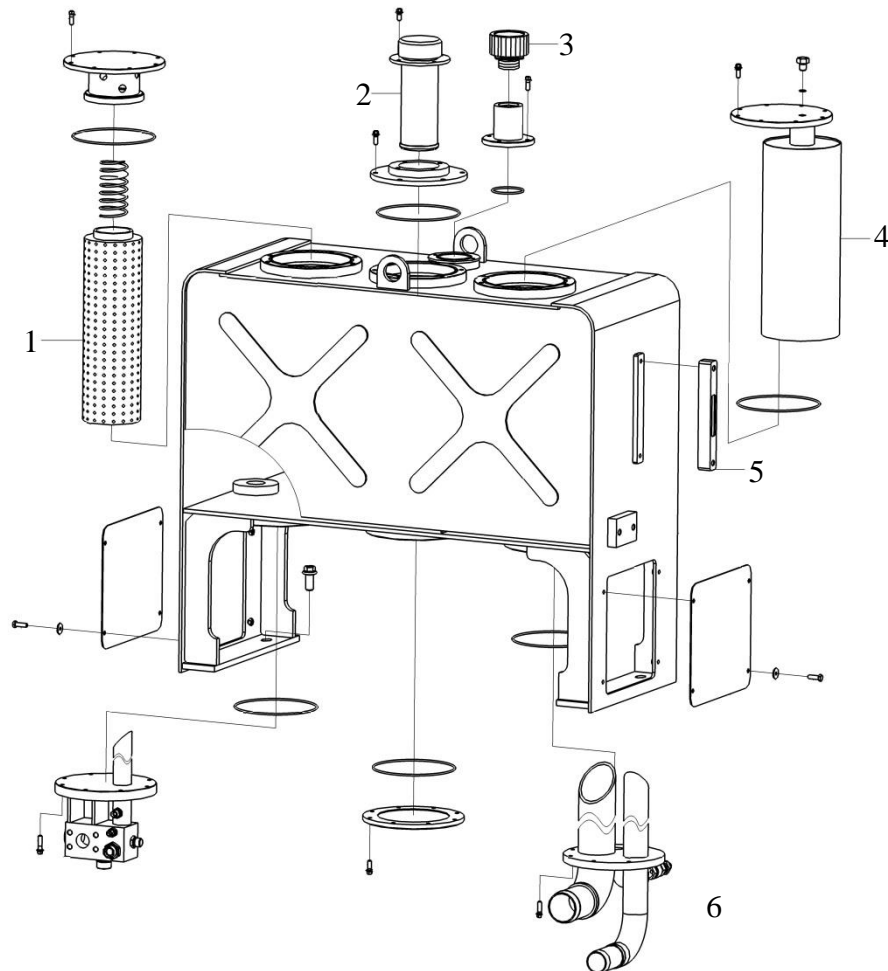

Fig. 9-22 Hydraulic oil tank

- | | | | |
|---------------------|------------------------------|--------------|-------------------------|
| 1 Oil return filter | 2 Oil filling filter element | 3 Air filter | 4 Oil absorption filter |
| 5 Oil pointer | 6 Oil drain valve | | |

Hydraulic tank components description:

1. Oil return filter: Used to filter oil contamination out. If there is too much contamination accumulated in filter element, which will increase pressure difference between two sides of the filter, the filter build-in bypass valve will open if the pressure difference reaches its opening pressure, oil will be released through bypass valve to ensure normal operation of hydraulic system.
2. Air filter: Used to balance the air pressure inside the tank and atmospheric pressure.
3. Oil pointer: Used to check hydraulic oil level.
4. Oil draining valve: Used to drain the oil in hydraulic tank.

Disassembly and assembly of hydraulic oil tank

★ ATTENTION

Before dismantling the hydraulic oil tank, be sure to carefully read the *service precautions for working hydraulic system* previously exposed in this chapter.



Fig. 9-23



Fig. 9-24

1. Oil drain valve



Fig. 9-25

1 Platform

2 Engine hood

Disassembly of hydraulic tank

1. Drain oil.

Start the machine and drive it to the flat spacious place. Raise the boom to the highest position. Tilt the bucket backward, and then shut down the engine.

Push the control handle of the pilot valve towards right slowly. Let the bucket tilt forward gently to drain the oil in bucket cylinder.

After the bucket reaches its extreme position, push the handle forward gently. Let the boom falling slowly to drain the oil in boom cylinder. Keep the bucket flat on ground. Then operate the handle left and right, back and forth for 5~6 times to drain the internal oil pressure of the system.

- #### 2. Connect a hose to the oil draining valve on the bottom of hydraulic tank, and put the other end in a clean vessel. Open the draining valve of the tank to drain the hydraulic oil out. (Open the filling cap of the tank to accelerate the draining speed)

★ ATTENTION

Cover the drained oil to prevent contamination.

- #### 3. Remove the engine hood. Refer to **Disassembly of Engine Hood** in chapter 8.

- #### 4. Remove the left and right platforms.



1

Fig. 9-26

1 Maintenance side plate

5. Remove the fixing bolts of hydraulic tank left and right maintenance side plates, take down the plates.



1

Fig. 9-27

1 Clamp

6. Remove the fixing clamps of two oil absorption rubber hoses.



1 2 3 4 5

Fig. 9-28

1 Mutitandem valve oil return hose
 2 Pilot pump oil overflow hose
 3 Priority valve oil return hose
 4 Steering gear oil return hose
 5 Pilot oil return hose

7. Disconnect all hydraulic tank oil return rubber hoses.



1

Fig. 9-29
1 Bolt



1

Fig. 9-30
1 Bolt



1 2 3 4 5

Fig. 9-31
1 Mutitandem valve oil return hose
2 Pilot pump oil overflow hose
3 Priority valve oil return hose
4 Steering gear oil return hose
5 Pilot oil return hose

8. Hang the hydraulic oil tank stably with lifting rope, and remove the four fixing bolts. Lift down the tank (Pay attention to disconnect oil outlet hose from hydraulic oil tank).

Assembly of hydraulic oil tank

1. Lift up the hydraulic oil tank and put it on rear frame, and adjust it to the right position, fix it with four M16×35 bolts.

 193~257Nm

2. Connect all hydraulic tank oil return rubber hoses.



Fig. 9-32
1 Clamp

3. Connect steering pump oil absorption rubber hose and radiating pump oil absorption rubber hose to hydraulic oil tank with two clamps respectively.



Fig. 9-33
1 Maintenance side plate

4. Install hydraulic tank left and right maintenance side plates with M8×20 bolts.



Fig. 9-34
1 Platform 2 Engine hood

5. Install the engine hood. Refer to **Assembly of Engine Hood** in chapter 8.
6. Install the left and right platforms.

933 Multitandem Valve

The multitandem valve is mainly composed of valve body, boom slide valve part, bucket slide valve part, reserved slide valve part, main safety valve, bucket bi-directional overload valve and check valves. The three slide valve parts are in series.

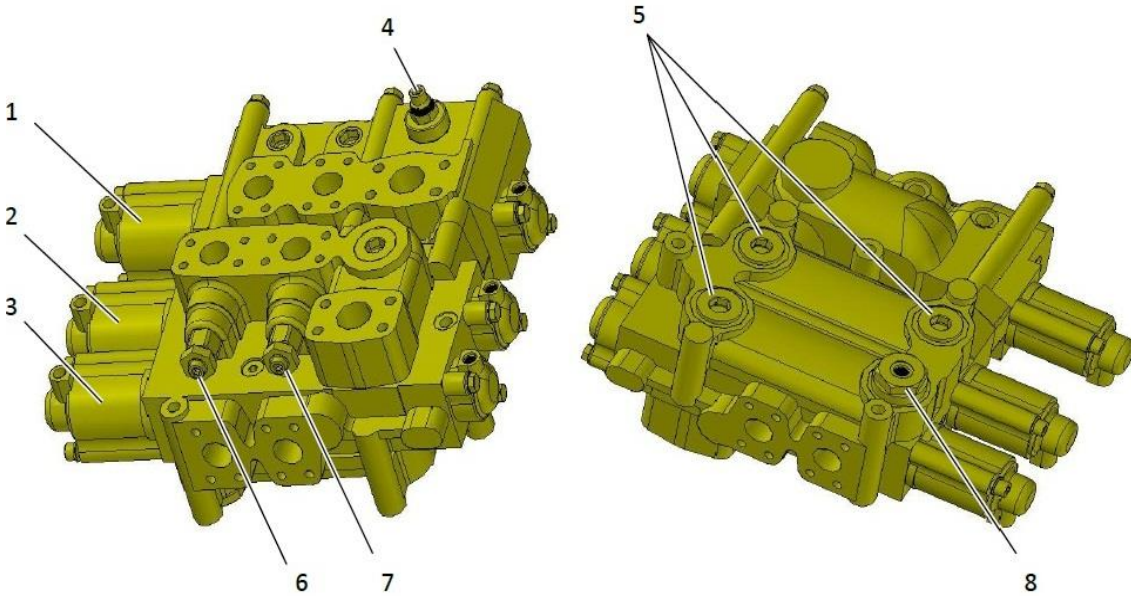

Figure 9-35

- 1 Reserved part 2 Bucket slide valve part 3 Boom slide valve part
- 4 Main safety valve 5 Check valve 6 Overload valve for bucket cylinder rod-side chamber
- 7 Overload valve for bucket cylinder piston-side chamber 8 Logical valve

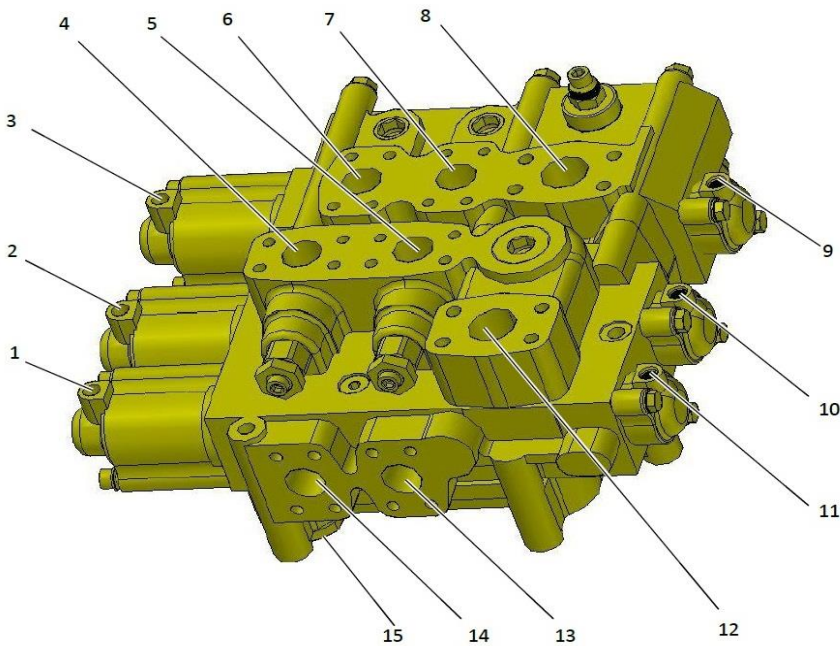

Fig. 9-36

- 1 Control lifting of boom, a2 2 Control backward tilt of bucket, a1

- | | |
|---|---|
| 3 Control the reserved part, a3 | 4 To rod-side chamber of bucket cylinder, B1 |
| 5 To piston-side chamber of bucket cylinder, A1 | |
| 6 To rod-side chamber of the reserved part, B3 | 7 To piston-side chamber of the reserved part, A3 |
| 8 Oil inlet port of multiandem valve, P | 9 Control the reserved part, b3 |
| 10 Control forward tilt of bucket, b1 | 11 Control falling of boom, b2 |
| 12 Oil outlet port of multiandem valve, T | 13 To piston-side chamber of boom cylinder, A2 |
| 14 To rod-side chamber of boom cylinder, B2 | 15 Control floating of boom, K |

Bucket slide valve part, disassembly and assembly

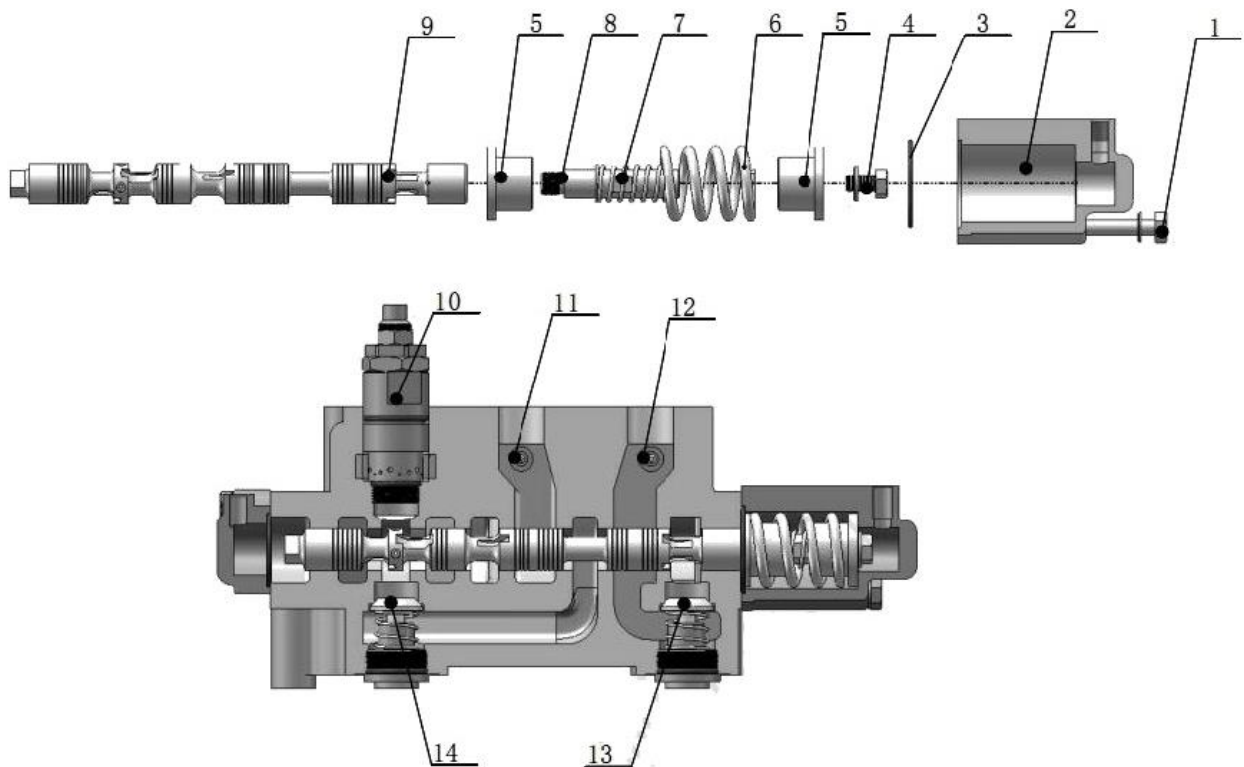

Fig.9-37

Valve element disassembling method:

- Step 1: Remove the M10×100 hexagon bolt 1 with a hexagonal wrench (with mark 16).
- Step 2: Take down the end cover 2 and O-ring 3.
- Step 3: Remove the M12×20 hexagon bolt 4 with a hexagonal wrench.
- Step 4: Remove spring seat 5, spring 6, 7 and put them orderly.

★ATTENTION

Rinse all the parts before assembling, clean with compressed air and make sure no infiltration of oil dirt and foreign matters.

9 Bucket slide valve element

10 Safety valve: Provide overloaded security protection.

11 High pressure overload valve: When bucket is subject to external shock or interference with other mechanisms, overload valve will open to provide overloaded security protection.

12 Low pressure overload valve: When bucket is subject to external shock or interference with other mechanisms, overload valve will open to provide overloaded security protection.

13 Check valve: Used to refill the rod-side chamber when cavitation happens.

14 Check valve: Used to prevent bucket dive.

Operation schematic diagram for retracting the bucket

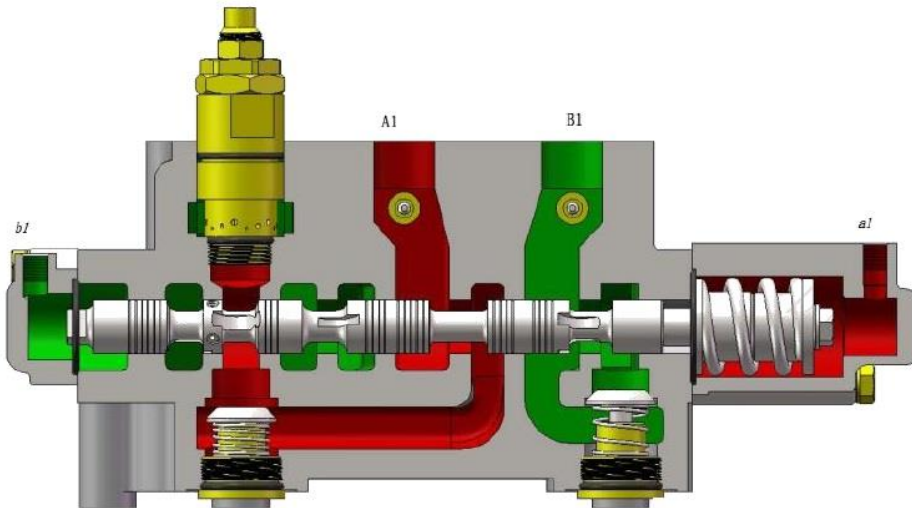

Fig. 9-38

- Pilot control oil goes into port a1 to force valve element left.
- Working oil enters into multiandem valve through port P, then goes through check valve and the oil channel inside to working port A1, finally flows into working cylinder.
- Oil in the other chamber of working cylinder returns back to hydraulic tank through port B1 and oil channel inside.

Note: Red represents high pressure oil, green represents low pressure return oil.

Operation schematic diagram for extending the bucket

Fig. 9-39

- Pilot control oil goes into port b1 to force valve element right.
- Working oil enters into multiandem valve through port P, then goes through check valve and the oil channel inside to working port B1, finally flows into working cylinder; When oil supply of port P is insufficient, check valve in B1 will open under the action of backpressure to supply oil to B1.
- Oil in the other chamber of working cylinder returns back to hydraulic tank through port A1 and oil channel inside.

Boom slide valve part, disassembly and assembly

Fig. 9-40

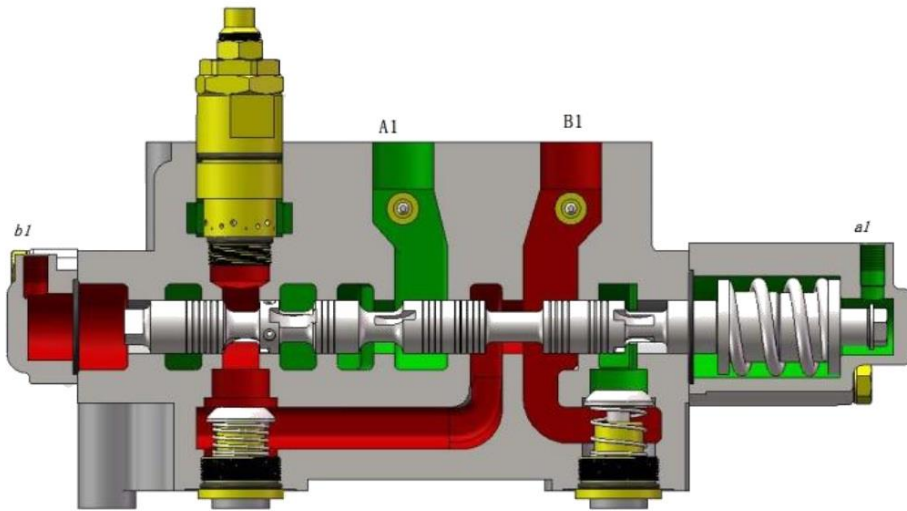
Valve element disassembling method:

Step 1: Remove the M10×100 hexagon bolt 1 with a hexagonal wrench.

Step 2: Take down the end cover 2 and O-ring 3.

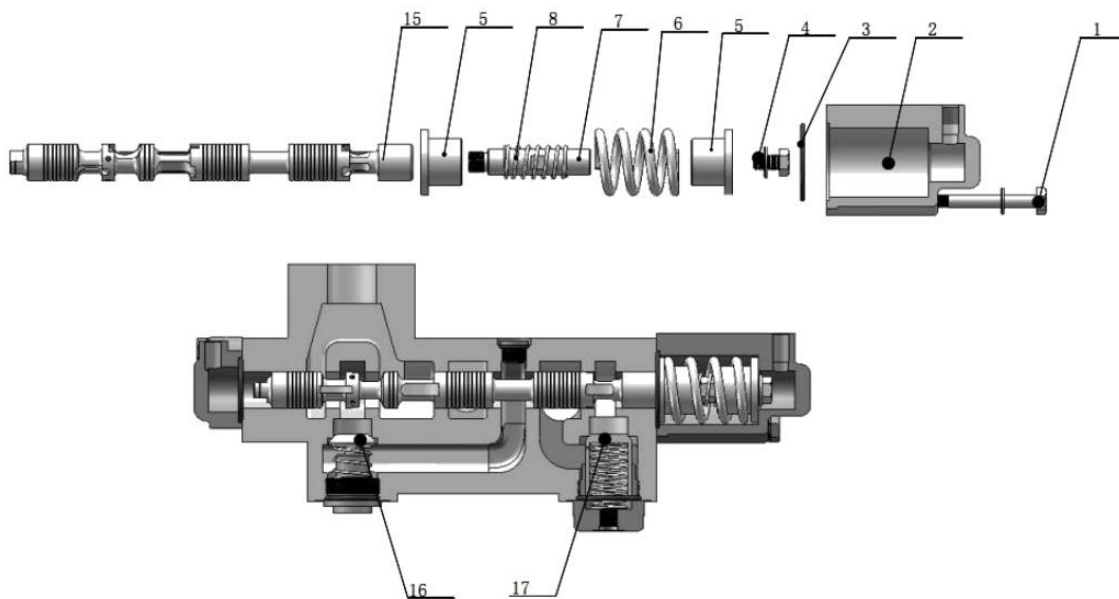
Step 3: Remove the M12×20 hexagon bolt 4 with a hexagonal wrench.

Step 4: Remove spring seat 5, spring 6, 8 and put them orderly.

★ ATTENTION

Rinse all the parts before assembling, clean with compressed air and make sure no infiltration of oil dirt and foreign matters.

15 Boom slide valve element

16 Check valve: Used to prevent bucket dive.

17 Oil complementary valve: Used to refill the rod-side chamber when cavitation happens; Used to realize floating of boom.

Operation schematic diagram for lifting the boom

Fig. 9-41

- Pilot control oil goes into port a2 to force valve element left.
- Working oil enters into multiandem valve through port P, then goes through check valve and the oil channel inside to working port A2, finally flows into working cylinders.
- Oil in the other chamber of working cylinder returns back to hydraulic tank through port B2 and oil channel inside.

Note: Port k of multiandem valve connects to port 2C of pilot valve.

Red represents high pressure oil, green represents low pressure return oil.

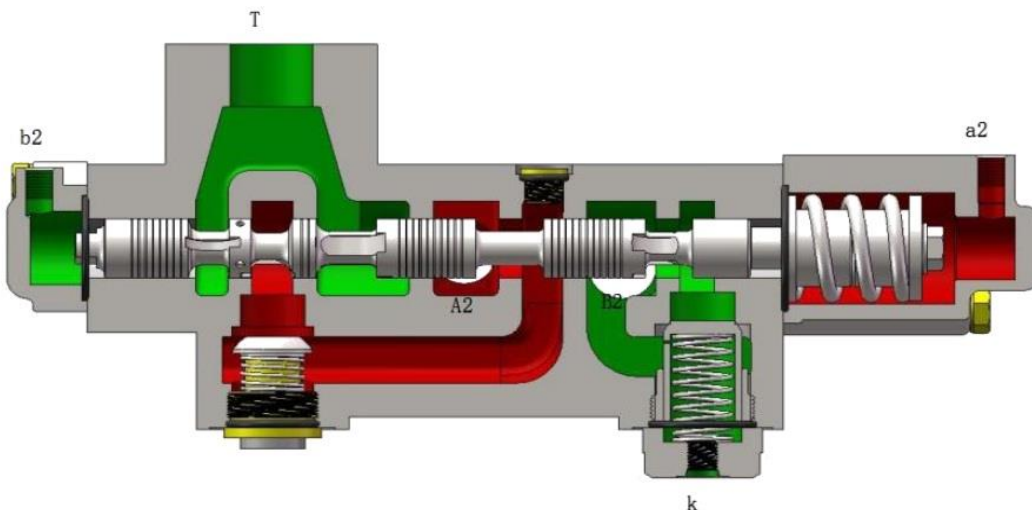
Operation schematic diagram for falling of boom

Fig. 9-42

- Pilot control oil goes into port b2 to force valve element right.
- Working oil enters into multiandem valve through port P, then goes through check valve and the oil channel inside to working port B2, finally flows into working cylinders.
- Oil in the other chamber of working cylinder returns back to hydraulic tank through port A2 and oil channel inside.

Operation schematic diagram for boom floating

Fig. 9-43

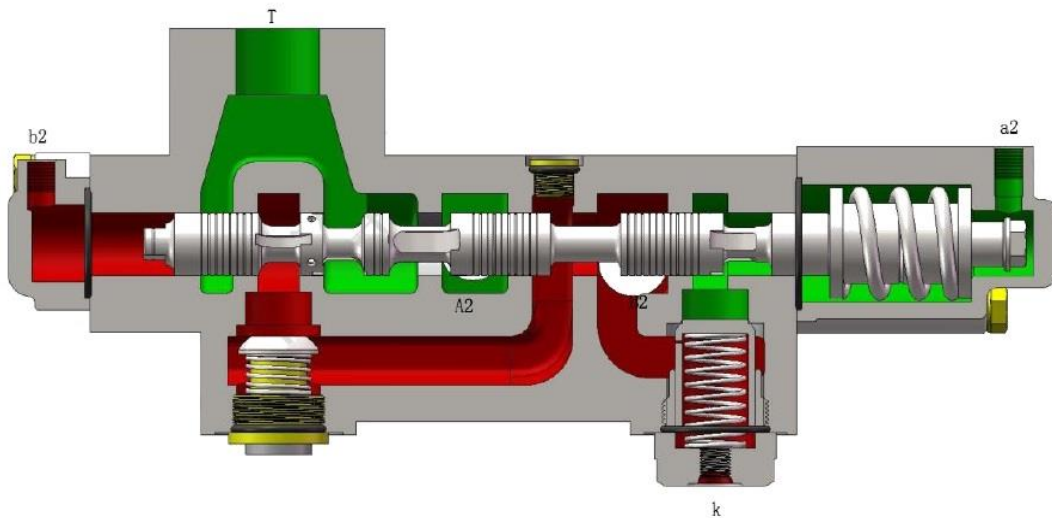
Due to port k of multiandem valve connects to port 2C of pilot valve; by operating the pilot valve, port 2C will be connected to oil return circuit, port k of multiandem valve communicates with oil return circuit too, under the action of back pressure, oil complementary will open.

- Pilot control oil goes into port b2 to force valve element right.
- Working oil enters into multiandem valve through port P, then goes through check valve, the

oil channel inside and oil complementary to oil return circuit.

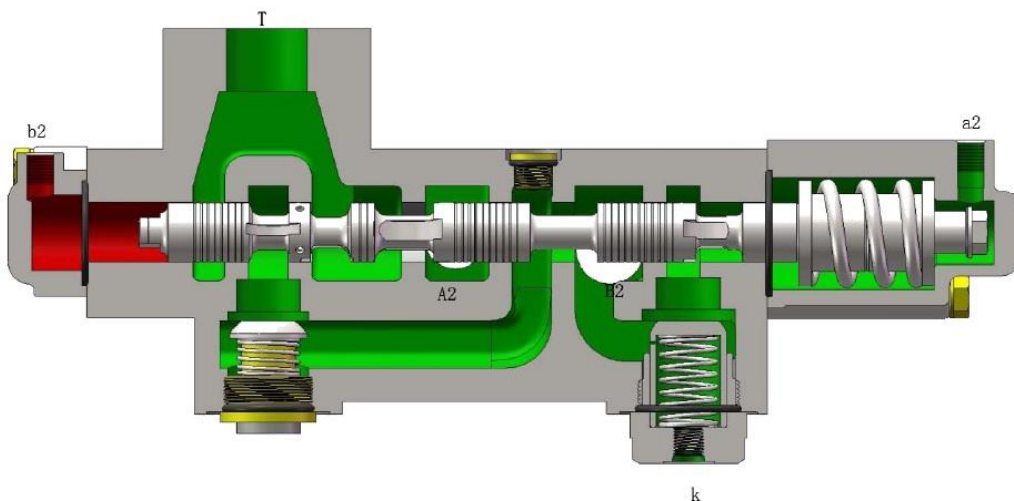
- Oil in working cylinders returns back to hydraulic tank through port B2, oil complementary valve and oil channel inside.

Note: Red represents high pressure oil, green represents low pressure return oil.

Working principle, disassembling and assembling method for the reserved slide valve part is the same as the bucket part.

Common faults and elimination methods for multiandem valve

Table 9-2

S/N	Fault	Cause	Solution
1	Unexpected bucket (auto) retracting, falling.	High pressure overload valve element is stuck.	Disassemble and wash the high pressure overload valve or replace.
		Severe internal leakage in bucket cylinder.	Consult cylinder manufacturer.
2	Bucket is powerless.	Low pressure overload valve element is stuck.	Disassemble and wash the low pressure overload valve or replace.
		Severe internal leakage in bucket cylinder.	Consult cylinder manufacturer.
3	Boom lifting is powerless and slow.	Safety valve element is stuck.	Disassemble and wash the safety valve or replace.
		Low safety valve set pressure	Remove the lead seal, unscrew the lock nut, rotate the pressure adjusting screw rod clockwise to raise safety valve set pressure, and then tighten the lock nut.
		Pump failure.	Check and repair the pump.
4	Unexpected further dropping of boom	Severe internal leakage in boom cylinder.	Consult cylinder manufacturer.
		Severe leakage when valve is in neutral.	Replace the whole valve.
5	External oil leakage	Damaged O-ring.	Replace the O-ring.
		Related fastener is loose.	Tighten the fastener.

Pressure adjustment of multiandem safety valve

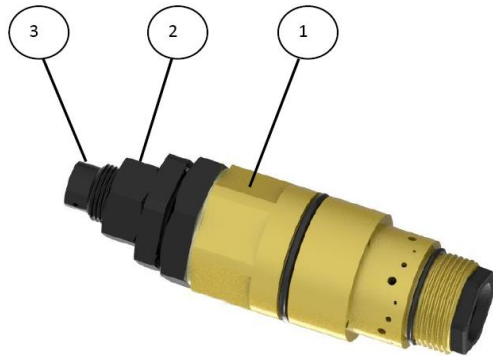

Fig. 9-44

1 Safety valve 2 Lock nut 3 Pressure adjustment screw rod

Adjustment method:

- Step 1: Remove the lead seal and protection cover of pressure adjustment screw rod 3.
- Step 2: Unscrew the lock nut 2.
- Step 3: Use an 8mm internal hexagonal wrench to rotate pressure adjustment screw rod 3, clockwise to increase and anticlockwise to decrease. After the adjusting, tighten lock nut 2.
- Step 4: Use a thin iron wire to run through the pin hole on pressure adjustment rod 3 and pretention cover, close off with lead seal.

Pressure adjustment of multiandem overload valve

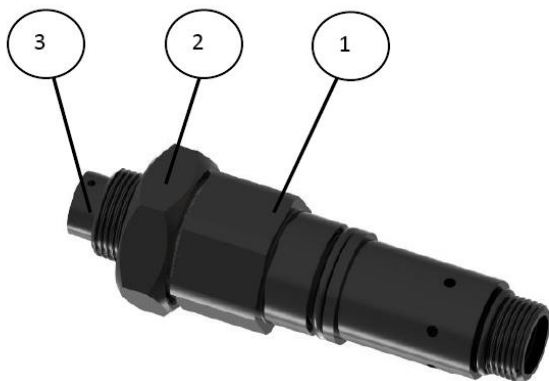

Fig. 9-45

1 Overload valve 2 Lock nut 3 Pressure adjustment screw rod

Adjustment method:

- Step 1: Remove the lead seal and protection cover of pressure adjustment screw rod 3.
- Step 2: Unscrew the lock nut 2.

- Step 3: Use an 8mm internal hexagonal wrench to rotate pressure adjustment screw rod 3, clockwise to increase and anticlockwise to decrease. After the adjusting, tighten lock nut 2.
- Step 4: Use a thin iron wire to run through the pin hole on pressure adjustment rod 3 and pretention cover, close off with lead seal.

Disassembly and assembly of multitandem valve

★ ATTENTION

Before dismantling multitandem valve, be sure to carefully read the *service precautions for working hydraulic system* previously exposed in this chapter.

Disassembly of the multitandem valve



Figure 9-46

1. Start the machine and approach the bearing frame (put the bearing frame on flat spacious ground in advance), adjust the location of the machine. Raise the boom to the highest position. Tilt the bucket backward to the extreme position. Push the control handle of the pilot valve towards right gently. Let the bucket tilt forward to its extreme position, push the handle forward gently, to let the boom falling on the bearing frame. Then operate the handle left and right, back and forth for 5~6 times to drain the internal oil pressure of the system.



Figure 9-47

2. Wedge the loader tires with wood blocks stably.



Figure 9-48
1 Cover plate

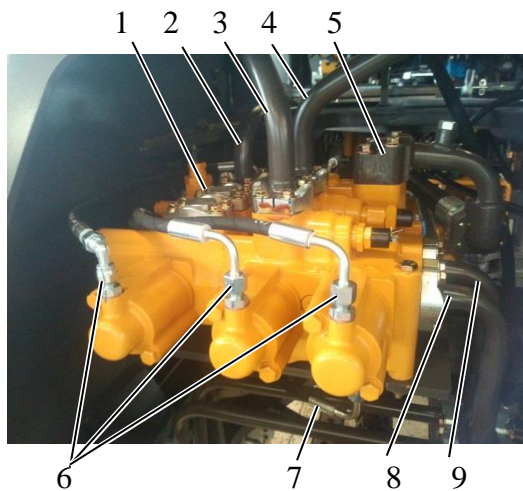

Figure 9-49
1 Dust cap
2 Mutitandem valve oil inlet steel pipe
3 Bucket cylinder rod-side steel pipe
4 Bucket cylinder piston-side steel pipe
5 Mutitandem valve oil return steel pipe
6 Pilot control oil pipe
7 Rubber hose of K port
8 Boom cylinder rod-side steel pipe
9 Boom cylinder piston-side steel pipe

3. Remove the fixing bolts on front cover plate and take the front cover plate down.

4. Disconnect all pilot control oil pipes and the rubber hose of port K
5. Remove the connecting flanges of boom cylinder rod-side and piston-side steel pipes, and remove connecting flanges of bucket cylinder rod-side and piston-side steel pipes, disconnect them all from multitandem valve.
6. Remove the flanges and dust caps of multitandem valve reserved part.
7. Remove the flanges of multitandem valve oil inlet and return steel pipes, take down the pipes.

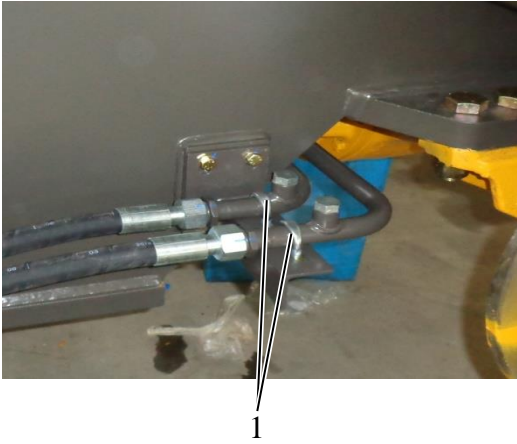

Figure 9-50
1 U-shape bolt

8. Loosen the U-shape fixing bolts of boom slide valve part rod-side and piston-side steel pipes. (Doesn't need to be removed).

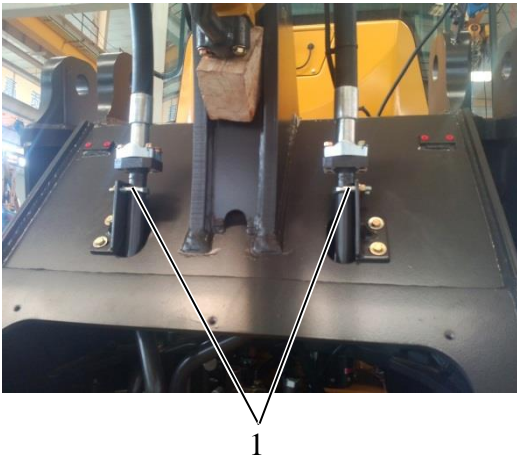

Figure 9-51
1 U-shape bolt

9. Loosen the U-shape fixing bolts of bucket slide valve part rod-side and piston-side steel pipes. (Doesn't need to be removed).

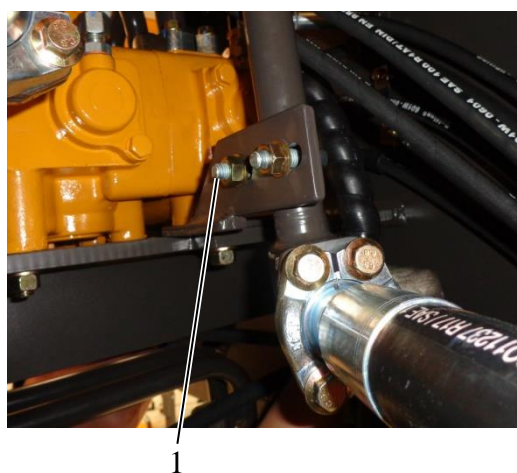
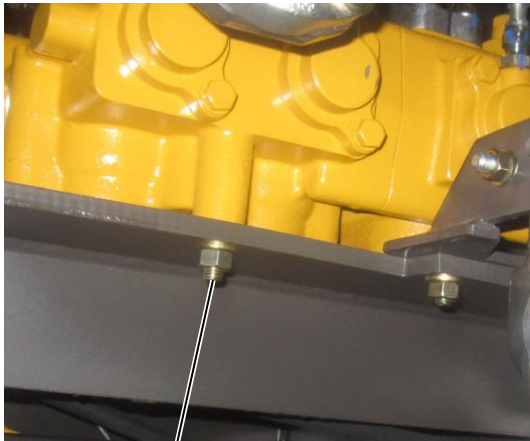

Figure 9-52
1 U-shape bolt

10. Loosen the U-shape fixing bolt of multiandem valve oil inlet steel pipe. (Doesn't need to be removed).



1

Figure 9-53
1 Bolt

11. Disassemble the three fixing bolts between multitandem valve and front frame, lift down the valve.

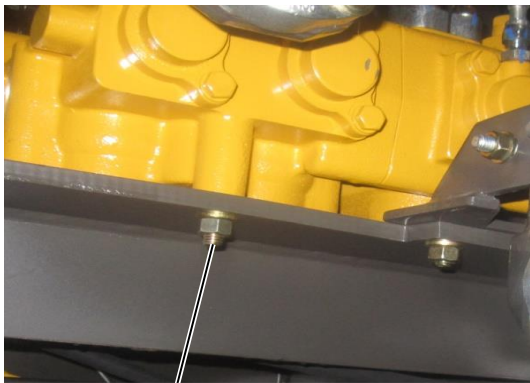

1

Figure 9-54
1 Bolt

Assembly of the multitandem valve

1. Hang the valve up and put it on front frame, fix it on the frame with bolts.

 kgm 90±15Nm

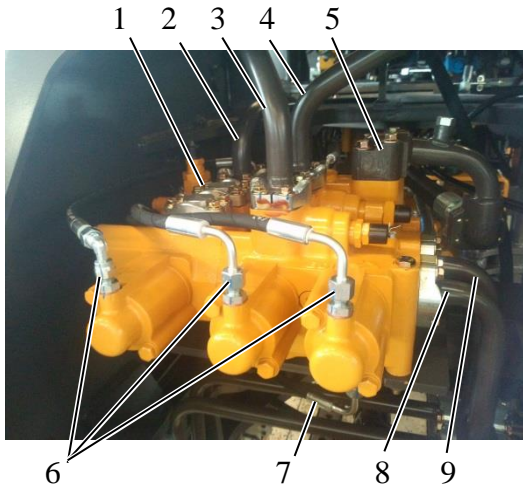



Figure 9-55

- 1 Dust cap
- 2 Mutitandem valve oil inlet steel pipe
- 3 Bucket cylinder rod-side steel pipe
- 4 Bucket cylinder piston-side steel pipe
- 5 Mutitandem valve oil return steel pipe
- 6 Pilot control oil pipe
- 7 Rubber hose of K port
- 8 Boom cylinder rod-side steel pipe
- 9 Boom cylinder piston-side steel pipe

2. Install multiadem valve oil inlet and return steel pipes

3. Install bucket and boom slide valve part rod-side and piston-side steel pipes.

 52±10Nm

4. Install all pilot control oil pipes and rubber hose of port K.

 35±5Nm

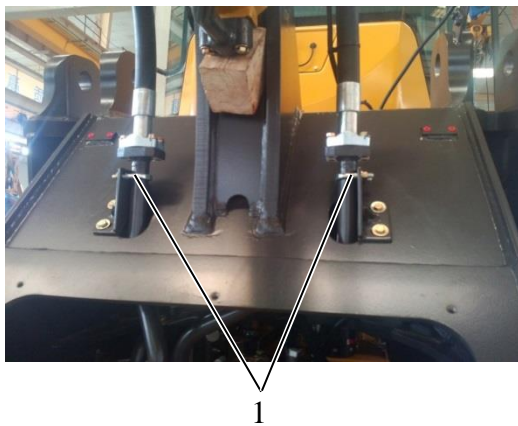

Figure 9-56

- 1 U-shane bolt

5. Tighten the U-shape fixing bolts of bucket slide valve part rod-side and piston-side steel pipes.



Figure 9-57
1 U-shape bolt

6. Tighten the U-shape fixing bolts of boom slide valve part rod-side and piston-side steel pipes.



1
Figure 9-58
1 U-shape bolt

7. Tighten the U-shape fixing bolt of multiandem valve oil inlet steel pipe.

934 Pilot Operating Valve

Pilot operating valve is installed in the cab, right side of the operator seat; it is a stacked double-piece valve. The valve is composed of boom operating part and bucket operating part. Boom slide valve part and bucket slide valve part in multitandem valve can be controlled by operating this valve, and then the working device can be controlled in this way.

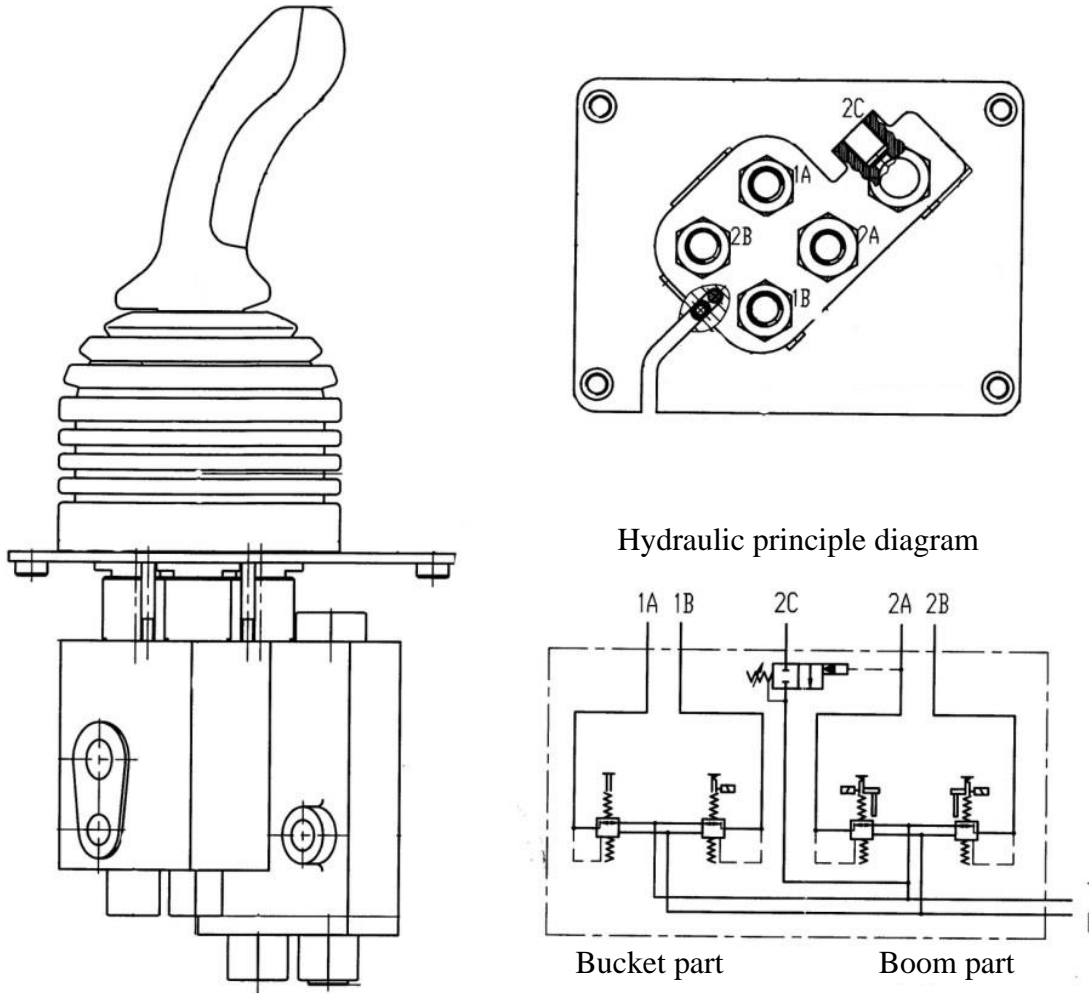

Fig. 9-59

Table 9-3 Pipe connections and control relationship

	Pilot valve oil port	Multitandem pilot oil port	Controlled port of multitandem valve	Function
Bucket operating part	4	a1	A1	Retract bucket (backward tilt)
	2	b1	B1	Unload (forward tilt)
Boom operating part	3	b2	A2	Falling
	1	a2	B2	Lifting
	5	k	A2, B2	Floating

935 Hydraulic Cylinders

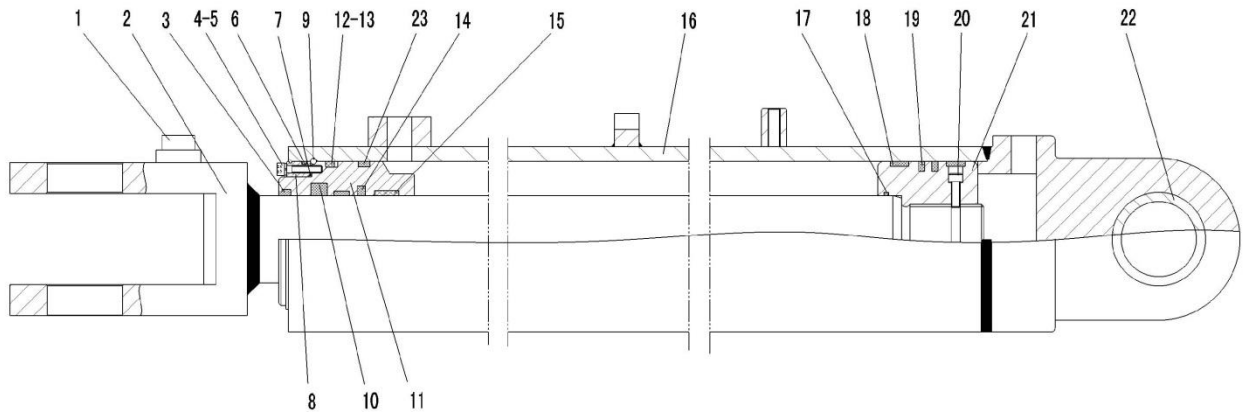

Fig. 9-60 Boom hydraulic cylinder

- | | | | | | |
|-------------------|---------------------|---------------------------|-------------------------|-----------------|----------|
| 1 Screw seat | 2 Piston rod | 3 Dust ring | 4 Screw | 5 Gasket | 6 O-ring |
| 7 O-ring | 8 Baffle ring | 9 Steel cable baffle ring | 10 Seal ring BS | 11 Guide ring | |
| 12 O-ring | 13 FTFE baffle ring | | 14 Cushion seal ring BR | 15 Bearing ring | |
| 16 Cylinder block | | 17 O-ring | 18 Bearing ring | 19 SPGO | |
| 20 Screw | 21 Piston | 22 Sleeve | | | |

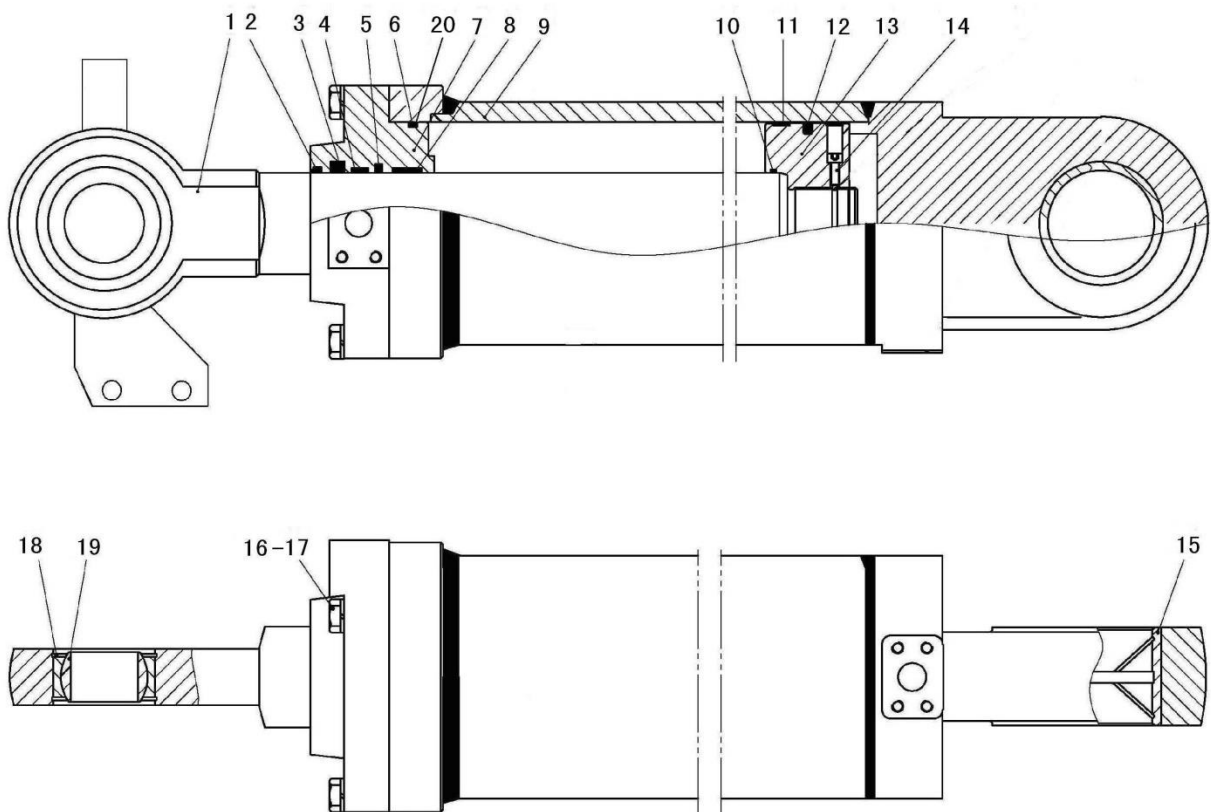

Fig. 9-61 Bucket hydraulic cylinder

- | | | | | |
|------------------------|----------------|-----------------|----------------|----------------|
| 1 Piston rod | 2 Dust ring A1 | 3 Seal ring BS | 4 Bearing ring | |
| 5 Cushion seal ring BR | | 6 O-ring | 7 Guide sleeve | 8 Bearing ring |
| 9 Cylinder block | 10 O-ring | 11 Bearing ring | 12 SPGO | 13 Piston |
| 14 Screw | 15 Sleeve | 16 Screw | 17 Gasket | 18 Baffle ring |
| 19 Knuckle bearing | | | | |

Disassembly and assembly of boom cylinders

★ ATTENTION

Before dismantling the boom cylinders, be sure to carefully read the *service precautions for working hydraulic system* previously exposed in this chapter.

Disassembly of the boom cylinder

1. Start the machine and approach the bearing frame (Put the bearing frame on flat spacious ground in advance), adjust the location of the machine. Raise the boom to the highest position. Tilt the bucket backward to the extreme position. Push the control handle of the pilot valve towards right gently to let the bucket tilt forward to its extreme position, and then push the handle forward gently, to let the boom falling on the bearing frame. Then operate the handle left and right, back and forth for 5~6 times to drain the internal oil pressure of the system
2. Loosen the connecting bolts between steel pipes and rubber hoses of boom cylinder rod-side and piston-side respectively, and then remove the bolts, fission flanges and O-rings, take down the rubber hoses



Fig 9-62

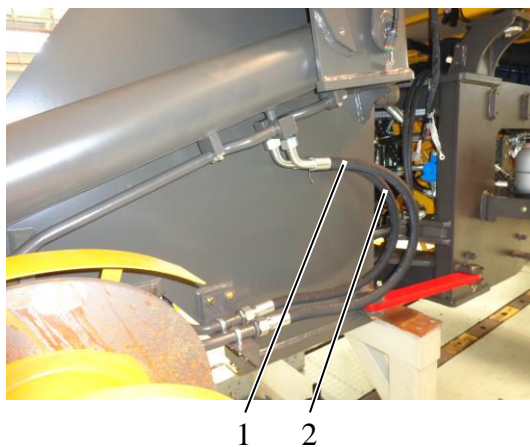

Fig 9-63

- 1 Boom cylinder rod-side rubber hose
- 1 Boom cylinder piston-side rubber hose

Fig 9-64
1 Pin
2 Bolt

Fig 9-65
1 Pin

Fig 9-66
1 Bolt
2. Pin

3. Bind the cylinder body with lifting rope and lift it up a bit. Then loosen boom cylinder front pin fixing bolt, remove the bolt and gaskets.

4. Disassemble boom cylinder front pin, remove the adjusting gasket, and avoid scratching the pin during the operation.

5. Loosen the fixing bolt of the pin that connecting boom cylinder to front frame, support the boom and remove the pin with a rubber hammer. Lift the boom cylinder down.

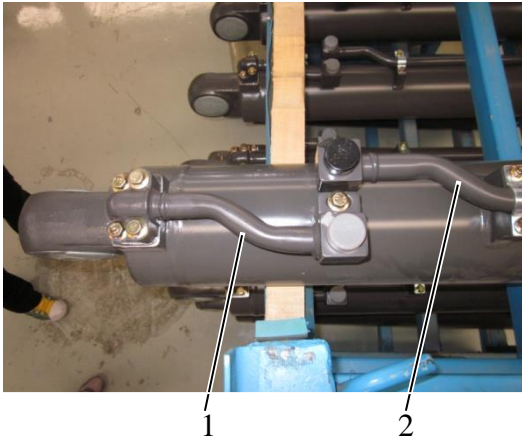

Fig 9-67

- 1 Boom cylinder piston-side steel pipe
- 2 Boom cylinder rod-side steel pipe

6. Remove boom cylinder piston-side and rod-side steel pipes

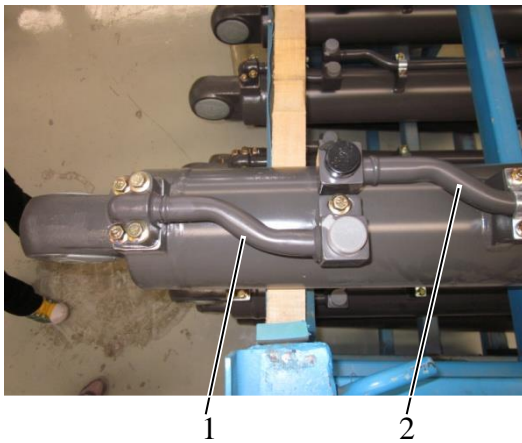

Fig 9-68

- 1 Boom cylinder piston-side steel pipe
- 2 Boom cylinder rod-side steel pipe

Assembly of the boom cylinder

1. Install the fixing bolts of boom cylinder piston-side and rod-side steel pipes.



 Nm 52±10Nm



Fig 9-66

- 1 Bolt
- 2. Pin

2. Bind the cylinder body with lifting rope and lift it to assembling position.
3. Apply some grease on boom cylinder rear pin, and then use it to connect cylinder to the front frame.
4. Fix boom cylinder rear pin with bolt.

 Nm 225±40Nm



1

Fig 9-70

1 Boom cylinder front pin



1 2

Fig 9-71

1 Boom cylinder rod-side rubber hose
1 Boom cylinder piston-side rubber hose



Fig 9-72

5. Apply some grease on boom cylinder front pin, add a gasket, and then start the engine. Operate pilot handle to adjust stroke of boom cylinder piston rod, keep its connecting hole aligned with the pin joint hole on boom, and connect them with pin.

★ ATTENTION

Be careful when assembling the boom cylinder, the screw seat on piston rod head should be on outside; use proper numbers of gaskets to ensure the clearance between piston rod head end face and boom is within 0.5~1.5mm.

6. Install boom cylinder front pin fixing bolt.
7. Install rubber hoses of boom cylinder rod-side and piston-side.

8. Add grease to boom cylinder front and rear pin grease cup until there is grease squeezed out of the fitting surface.

Disassembly and assembly of bucket cylinder

★ ATTENTION

Before dismantling the bucket cylinder, be sure to carefully read the *service precautions for working hydraulic system* previously exposed in this chapter.

Disassembly of the bucket cylinder

1. Drain oil.

Start the machine and drive it to flat spacious place. Raise the boom to the highest position. Tilt the bucket backward to the extreme position, and then shut down the engine.

Push the control handle of the pilot valve towards right gently. Let the bucket tilt forward under the action of gravity to drain the oil in bucket cylinder.

After the bucket reaches its extreme position, push the handle forward gently. Let the boom falling under the action of gravity to drain the oil in boom cylinder. Keep the bucket flat on ground. Then operate the handle left and right, back and forth for 5~6 times to drain the internal oil pressure of the system.



Fig 9-73

2. Wedge the tires with wood blocks stably.

3. Remove the connecting bolts between flat fender and bucket cylinder piston rod head; remove the bolts, gaskets and flat fender.

4. Remove the fixing bolts between limiting lay-flat holder and bucket cylinder.



1 2

Fig 9-74

1 Flat fender

2 Limiting lay-flat holder

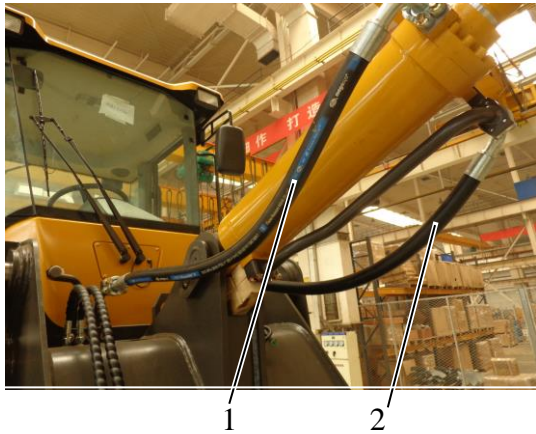

Fig 9-75

- 1 Bucket cylinder rod-side rubber hose
- 2 Bucket cylinder piston-side rubber hose

5. Disconnect the connecting bolts between bucket cylinder piston-side and rod-side rubber hoses and bucket cylinder, and then remove the bolts and fission flange, rubber hoses.



1

Fig 9-76

- 1 Pin

6. Bind the cylinder body with lifting rope and keep the rope with a certain pretension force. Remove the fixing bolt of pin that connecting the cylinder and rocker arm.
7. Dismount the connecting pin between bucket cylinder and rocker arm.



1

Fig 9-77

- 1 Pin

8. Lift up the cylinder, and make the cylinder body tend to upright. Remove the pin fixing bolt between cylinder and front frame, disassemble the pin.



1

Fig 9-78

1 Bucket cylinder piston-side oil inlet steel pipe



1

Fig 9-79

1 Bucket cylinder piston-side oil inlet steel pipe



1

Fig 9-80

1 Pin

9. Hang bucket cylinder down and remove piston-side oil inlet steel pipe.

Assembly of the bucket cylinder

1. Put O-ring in O-ring groove of bucket cylinder piston-side steel pipe, and fix the pipe on piston-side oil port with two M10×50 and two M10×55 bolts and gaskets separately. Use two M10×35 bolts and gaskets to fix the front end of bucket cylinder piston-side steel pipe on bucket cylinder screw seat.

 52±10Nm

2. Apply some grease on pin. Lift the cylinder up to proper position with lifting rope, use the pin to connect the cylinder to front frame.

★ ATTENTION

Put gaskets on connecting end faces, ensure the fitting clearance between two end faces is within 0.5~1.5mm by using different type and number of gaskets.

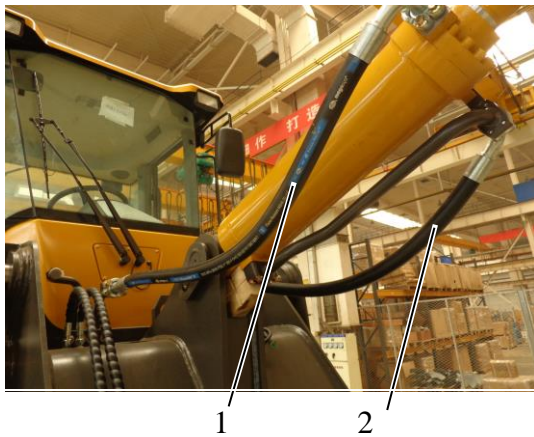
Fig 9-81

- 1 Bucket cylinder rod-side rubber hose
- 2 Bucket cylinder piston-side rubber hose

3. Install pin fixing bolt.
4. Put O-ring in O-ring grooves of bucket cylinder rod-side and piston-side rubber hoses, and then connect them to rod-side oil port and piston-side steel pipe with M10×30 bolts and fission flanges separately.

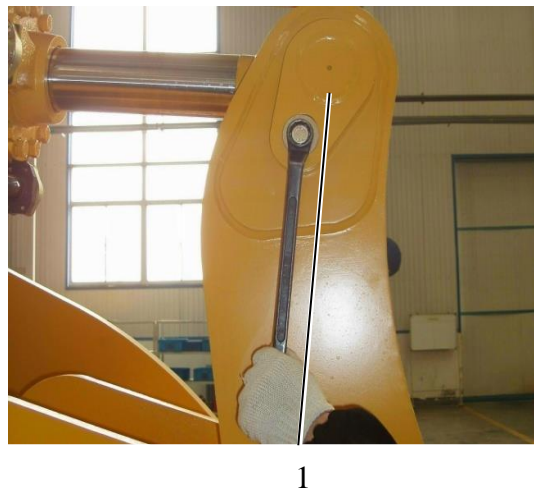
 52±10Nm

Fig 9-82

- 1 Pin

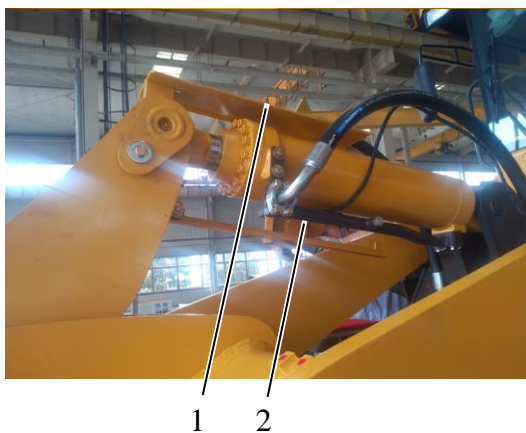
5. Start the engine and operate pilot handle to adjust stroke of bucket cylinder piston rod, keep its connecting hole aligned with the pin joint hole on bucket, and connect them with pin. Use proper types and numbers of gaskets to ensure the clearance between piston rod head end face and rocker arm is within 0.5~1.5mm.
6. Install pin fixing bolt.

Fig 9-83

- 1 Flat fender
- 2 Limiting lay-flat holder

7. Fix flat fender on bucket cylinder piston rod head with two M10×25 bolts and gaskets.
8. Assemble the connecting bolts between limiting lay-flat holder and bucket cylinder.



Fig 9-84

9. Add grease to all hinge points until there is grease squeezed out of the fitting surface. Check hydraulic oil level, add if necessary.

936 Pressure Selection Valve

Pressure selection valve is installed in pilot oil circuit, mainly composed of valve body, valve element and spring. Port P1 communicates with pilot pump oil outlet port, port P3 is connected to boom cylinder piston-side chamber, P2 is oil outlet port and connected to pilot valve, port T is oil return port.

The function of pressure selection valve: supply control oil (with a certain pressure) to pilot valve; ensure boom falling to the ground when the engine flameout.

During working, oil from pilot pump oil outlet port goes into port P1 of selection valve, and then flows into pilot valve through valve element center hole and oil outlet port P2. When pressure of oil in port P2 is larger than 1.5MPa, pressure selection valve element will move to left to cut off the channel between P1 and boom cylinder piston-side chamber. Port P3 is designed with a build-in check valve to prevent oil reflux.

When the engine flameout, port P1 has no pressure oil supply, and the valve element return back to its original position, where port P1 and P3 communicate with each other. At this point, if the boom is in raising state and operation handle in neutral, oil in boom cylinder piston-side chamber will be sealed. Push the handle to boom falling position by this time, oil in boom cylinder piston-side chamber will go into port P3 and its build-in check valve, and then flows into pilot valve to set the multiandem valve in “boom falling” position through port P2, and boom can be lowered. During this process, the valve element can ensure that oil pressure from port P3 to pilot valve is about 1.5MPa; if oil pressure in outlet port P2 increases, valve element will be forced left to enlarge throttle damping to decrease oil flow rate from port P3, thereby oil pressure in outlet port P2 will be decreased to desired range, the realization of pressure control is fulfilled.

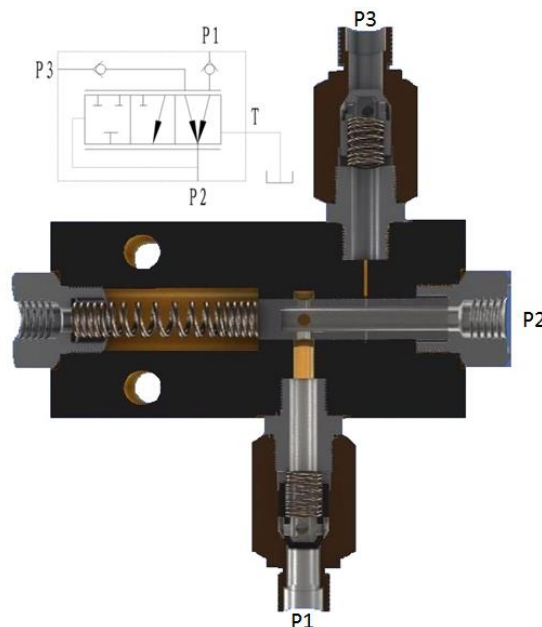

Fig. 9-85

94 Pressure Measuring Methods and Standards of Working Hydraulic System

Table 9-4

	Working pressure	Pilot pressure
Pressure measurement tools	Pressure gauge with the measuring range of 25MPa, three-way joint, piezometer tube	Pressure gauge with the measuring range of 6MPa, three-way joint
Pressure measuring point	Measuring port on multiandem valve oil inlet steel pipe	Related control port on multiandem valve
Pressure measuring standard	16MPa	3.5MPa
Required oil temperature for measurement	45~55°C	45~55°C

System working pressure measuring methods

Put the working device flat on ground, press parking brake switch, and then wedge the tires with wood blocks tightly, shut down the engine. Operate the pilot operating handle for 10 times and turn steering wheel left and right for about 5 times to release residual pressure in hydraulic circuit; prepare the measurement tools.

1. Connect measuring tools
 - Remove the plug of pressure measuring port;
 - Connect the three-way joint to pressure measuring port;
 - Connect piezometer tube to the three way joint;
 - Connect pressure gauge with the measuring range of 25MPa to the tube.
2. Start the engine, and operate the pilot operation handle to retract the bucket. After the bucket gets to its extreme position, increase the accelerator to the maximum size (2200r/min) gradually. Observe the pressure gauge and record the steady pressure value, and that is the current working pressure for working hydraulic system.
3. To get more accurate result, put the boom in other position and repeat the measurement.

System pilot pressure measuring methods

Put the working device flat on ground, press parking brake switch, and then wedge the tires with wood blocks tightly, shut down the engine. Operate the pilot operation handle for 10 times and turn steering wheel left and right for about 5 times to release residual pressure in hydraulic circuit;

prepare the measurement tools.

4. Connect measuring tools

- Connect the three-way joint to piezometer tube;
- Disconnect the to-be-measured control oil pipe;
- Connect three-way joint to the to-be-measured control oil port and connect the pipe to the joint too.
- Connect the pressure gauge with the measuring range of 6MPa to piezometer tube.

5. Start the engine, and operate the pilot operation handle to retract the bucket.

6. After the bucket gets to its extreme position, increase the accelerator to the maximum size gradually. Observe the pressure gauge and record the steady pressure value, and that is the current control oil pressure for working hydraulic system.

7. Compare the observed value to the standard one.

95 Diagnosis and Solutions for Common Faults of Hydraulic System

(1) Unexpected forward tilt of bucket

Fault phenomena: When operation handle of pilot valve is in neutral position, the bucket tilt forward unexpectedly.

Fault analysis: Due to link mechanisms are used in working device, when the bucket is under retract state and operation handle of pilot valve is in neutral position, the bucket cylinder piston-side chamber will suffer extra force caused by self-weight. At this point, if there is leakage in piston-side chamber, it will result in unexpected forward tilt of bucket.

Six situations can cause the leakage in piston-side chamber of bucket cylinder:

1. Obvious external leakage exists in pipelines, joints and fitting surfaces from the piston-side chamber to multitandem valve.
2. Multitandem valve bucket slide valve part fails to go back to neutral position (due to valve element gets stuck, valve element of pilot valve cannot reset or there are faults exist in the valve body, such as sand holes and grooves that connect to piston-side chamber).
3. While inner leakage exists in bucket cylinder, leakage also exists from rod-side chamber to oil outlet port.
4. Low overload pressure for bucket cylinder piston-side overload valve (may caused by damaged pressure adjusting spring, valve element stuck in open position, dirt exists in the conical fitting surface between valve element and valve body, or there are defects exist in the valve body, such as sand holes and grooves that connect to piston-side chamber).
5. Leakage exists in bucket cylinder piston-side oil compensation valve (may caused by damaged reset spring, valve element stuck in open position, dirt exists in the conical fitting surface between valve element and valve body, or there are defects exist in the valve body, such as sand holes and grooves that connect to piston-side chamber)
6. Excessive wear of selector valve body or element, which result in fit clearance between valve body and valve element is far more than design value.

Diagnosis and solutions:

1. Six situations that cause leakage are listed above and the simplest and easiest to diagnose is the first one: Start the machine and lift the boom to a certain height, retract the bucket to its extreme position, and then observe the pipelines, joints and fitting surfaces from the piston-side chamber to multitandem valve to find out whether there are obvious external leakage phenomena exist.

2. If the first situation is being excluded, consider the second situation: Start the machine and operate pilot valve handle to lift the boom to highest position, and retract the bucket to its extreme position, and then shut down the engine, disassemble the two pilot pipes that connected to two ends of multitandem valve bucket slide valve part. At this point, if the unexpected forward tilt phenomenon disappeared, then we can come to a conclusion that the fault is caused by pilot valve, which causes multitandem valve bucket slide valve part fails to go back to neutral position. Disassemble and clean the pilot valve or replace it. Otherwise, check the third situation.
3. For the third situation, we can do some simple check: Start the machine and operate pilot valve handle to lower the boom to lowest position, and retract the bucket to its extreme position, and then shut down the engine, disconnect bucket cylinder piston-side rubber hose and diver it to hydraulic oil tank. Start the machine again, operate the pilot valve handle to backward tilt the bucket, observe whether there is oil comes out from piston-side oil port continually. If there is, which means server inner leakage exists in bucket cylinder, the cylinder needs to be repaired or replaced. Otherwise, check the fourth and fifth situations.
4. For the fourth and fifth situations, method of pressure detection can be used: Connect a 0-250Bar pressure gauge to gauge port of bucket cylinder piston-side chamber. Start the machine and operate pilot valve handle to extend the bucket to its extreme position; step on the gas and operate pilot valve handle to lift the boom, at the same time, check whether the reading on the gauge reach the design value when the boom is lifting. If not, either situation mentioned in the first place is possible, the overload valve or oil compensation valve for bucket cylinder piston-side chamber need to be checked and cleaned.
5. If situation 1 to situation 5 have been excluded and the fault still exists, then stop the machine, low boom and bucket to lowest positions and disassemble multitandem valve bucket slide valve part, look through the valve element, valve opening and their fitting situation.
6. Excessive wear of selector valve body or element, which result in fit clearance between valve body and valve element is far more than design value.

(2) Boom sinking

Fault phenomena: When operation handle of pilot valve is in neutral position, the boom sinks automatically and exceeds allowed range.

Fault analysis: When the boom is lifted and stays in a certain height, the boom cylinder piston-side chamber will suffer extra force caused by self-weight. At this point, if there is leakage in piston-side chamber, the boom will fall automatically.

Five situations can cause the leakage in piston-side chamber of boom cylinder:

1. Obvious external leakage exists in pipelines, joints and fitting surfaces from the piston-side chamber to multitandem valve.
2. Multitandem valve boom slide valve part fails to go back to neutral position (due to valve element gets stuck, valve element of pilot valve cannot reset or there are defects exist in the valve body, such as sand holes and grooves), which cause boom cylinder rod-side chamber connect to pump, or piston-side chamber connect to oil return port.
3. While inner leakage exists in boom cylinder, leakage also exists from rod-side chamber to oil outlet port.
4. Malfunctioned selector valve of control oil combination valve, (may caused by machining defects, jammed valve element, inner leakage of pilot valve or defects exist in the valve body, such as sand holes and grooves), which make selector valve element fail to cut off the channel between boom cylinder piston-side chamber and combination valve and pilot valve, result in leakage in piston-side chamber of boom cylinder.
5. Excessive wear of selector valve body or element, which result in fit clearance between valve body and valve element is far more than design value.

Diagnosis and solutions:

1. Six situations that cause leakage are listed above and the simplest and easiest to diagnose is the first one: Start the machine and lift the boom to a certain height, and then observe the pipelines, joints and fitting surfaces from the piston-side chamber to multitandem valve to find out whether there are obvious external leakage phenomena exist.
2. If the first situation is being excluded, consider the second situation: Start the machine and operate pilot valve handle to lift the boom to highest position, and retract the bucket to its extreme position, and then shut down the engine, disassemble the two pilot pipes that connected to two ends of multitandem valve boom slide valve part. At this point, if the boom sinking phenomenon disappeared, then we can come to a conclusion that the fault is caused by pilot valve, which causes multitandem valve boom slide valve part fails to go back to neutral position. Disassemble and clean the pilot valve or replace it. Otherwise, check the third situation.
3. For the third situation, we can do some simple check: Start the machine and operate pilot valve handle to lift the boom to highest position, and retract the bucket to its extreme position, and then shut down the engine, disconnect boom cylinder rod-side rubber hose and divert it to hydraulic oil tank. Start the machine again, operate the pilot valve handle to higher the boom, observe whether there is oil comes out from rod-side oil port continually. If there is, which

means severe inner leakage exists in boom cylinder, the cylinder needs to be repaired or replaced. Otherwise, check the fourth situation.

4. For the third situation, we can do some simple check: Start the machine and operate pilot valve handle to lift the boom to highest position, and then shut down the engine. Open pilot valve oil return port, observe whether there is oil comes out. If there is, which means inner leakage of pilot valve causes the fault, the pilot valve needs to be repaired or replaced. Otherwise; If there is not, then open combination valve oil return port and check whether there is oil comes out, if there is, which means inner leakage of combination valve causes the fault, the combination valve needs to be repaired or replaced.
5. If situation 1 to situation 4 have been excluded and the fault still exists, then stop the machine, low boom and bucket to lowest positions and disassemble multistage valve boom slide valve part, look through the valve element, valve opening and their fitting situation.

(3) Boom rises slowly

Fault phenomena: When the diesel engine is running under rated speed, operate pilot valve handle to lift the boom from lowest to highest position, the time it needed exceeds full load lifting time.

Fault analysis: Consider the characteristics of Hydraulic power units, the reason for boom lifting slowly: insufficient flow from hydraulic pump to cylinder.

Ten situations are listed below that may cause insufficient flow from hydraulic pump to cylinder:

1. Severe external leakage exists in joints, pipelines, valves and fitting surfaces from pump to boom cylinder piston-side chamber.
2. The hydraulic oil contain a lot of bubble or turns black, or goes bad, and its viscosity has been changed.
3. Blocked oil absorption filter or oil absorption pipe, which make the working pump hard to suck oil.
4. Severe inner leakage exists in working pump.
5. Severe inner leakage exists in boom cylinder (caused by cylinder scoring or damaged sealing element).
6. Severe inner leakage exists between boom cylinder piston-side chamber and combination valve oil return port through selector valve.
7. Low adjusting pressure of multistage valve main safety valve (may caused by damaged pressure adjusting spring, valve element stuck in open position, or there are defects exist in the valve body, such as sand holes and grooves that connect to oil return chamber).

8. Severe inner leakage exists between oil inlet channel and oil return channel of multitandem valve body (caused by sand hole or breakage of valve body).
9. Excessive wear of selector valve element or valve opening of multitandem valve boom slide valve part, which result in fit clearance between valve body and valve element is far more than design value.
10. Insufficient opening of multitandem valve (due to selector valve element gets stuck, valve element of boom cylinder piston-side pilot valve cannot reset or there are sand holes and grooves exist in the valve body, or low setting pressure of combination valve that result in insufficient pilot pressure).

Diagnosis and solutions:

1. For all situations mentioned above, firstly, we should start the machine and lift the boom, check out whether there is obvious external leakage exists in pipelines, joints and fitting surfaces from working pump to boom cylinder piston-side chamber.
2. If there is no severe external leakage, then basic inspection should be done: Whether the hydraulic oil level is above “LOW” level, whether there is too much bubble in hydraulic oil or the oil turns black. Add hydraulic oil if necessary; if the oil turns bad, clean the tank and the whole hydraulic system, and then replace the oil.
3. If the hydraulic oil is good, then start the machine and operate pilot handle to retract the bucket, at the same time, listen carefully and check whether there is screaming in working pump. If there is, which means the pump have severe oil absorption problem, check and clean oil absorption filter and rubber hoses.
4. If there is no screaming phenomenon, check the forth situation: Start the machine, operate the pilot valve to load the pump for 1-2 minutes, then shut down the engine; carefully touch the shell of working pump, if it feels too hot, then we can come to a conclusion that severe inner leakage exist in working pump, which causes the oil shortage problem.
5. For the fifth to ninth situations, we need to do some simple tests first: Connect a 0-25Bar pressure gauge to gauge port of multitandem valve P port. Start the machine and operate pilot valve handle to pressurize the hydraulic system, at the same time, check whether the reading on the gauge reach the design value. If not, check situation 5 to 9 one by one.
6. For the fifth situation, start the machine and operate pilot valve handle to lower the boom to lowest position, and retract the bucket to its extreme position, and then shut down the engine, disconnect boom cylinder piston-side rubber hose and divert it to hydraulic oil tank. Start the machine again, operate the pilot valve handle to lower the boom, observe whether there is oil

comes out from piston-side oil port continually. If there is, which means server inner leakage exists in boom cylinder, the cylinder needs to be repaired or replaced.

7. For situation 6: Shut down the engine and operate pilot valve handle to lower the boom to lowest position, then reverse the check valve between boom cylinder piston-side chamber and combination valve.
8. For situation 7: Check and clean main safety valve, if there is irreparable damage for valve element or valve body, please replace the safety valve.
9. If situation 5 to 7 are being excluded and the system pressure still fails to reach design value, then focus on situation 8 and 9. Disassemble multitandem valve boom slide valve part, look through the valve element, valve opening and their fitting situation.
10. If the hydraulic system pressure reaches design value but the boom still lifting slow, check the tenth situation:
 - a) Operate pilot valve handle to lower the boom and bucket to their lowest positions, and then open the spring-free end cover(the one with short axial dimension) of multitandem valve boom slide valve part, force the valve element to do axial movement, check whether the rod can get to the right positions, whether it can return to neutral position smoothly.
 - b) Exchange control oil pilot pipes of bucket slide valve part and boom slide valve part, then start the machine and operate pilot valve, check whether the boom can be lifted normally. If it turns normal, check and clean pilot valve of multitandem valve boom slide valve part.

(4) Lifting incapacity of boom

Fault phenomena: When the diesel engine is running under rated speed, operate pilot valve handle to lift the boom under full load, the boom fails to be lifted.

Fault analysis: The most direct reason for lifting incapacity of boom is low pressure of boom cylinder piston chamber.

Primary reasons for low pressure in boom cylinder piston chamber:

1. Low overload pressure for main safety valve of multitandem valve (may caused by damaged pressure adjusting spring, valve element stuck in open position, or there are defects exist in the valve body, such as sand holes and grooves that connect to oil return chamber).
2. Severe inner leakage of working pump, due to that the system cannot build up pressure or the system pressure cannot reach design value.
3. Severe inner leakage exists in boom cylinder (caused by cylinder scoring or damaged sealing element).

4. Severe inner leakage exists between oil inlet channel and oil return channel of multitandem valve body (caused by sand hole or breakage of valve body), due to that the system cannot build up pressure or the system pressure cannot reach design value.

Diagnosis and solutions:

Focus on the four reasons mentioned above and refer to **Boom raises slowly** for troubleshooting.

(5) Bucket slow motion

Refer to **Boom raises slowly** for troubleshooting.

(6) Working incapacity of bucket

Refer to **Lifting incapacity of boom** for troubleshooting.



Shandong Lingong Construction Machinery Co.,Ltd

Address:Lingong Industry Park,Linyi Economic Development Zone,Shandong,China

Tel:0086-531-66590966

Fax:0086-531-66590959

Customer Service Tel:0086-531-66590955

Email:export@sdlg.com.cn

<http://www.sdlg.cn>